

Installation Instructions



NOTE: Read the entire instruction manual before starting the installation.

SAFETY CONSIDERATION

⚠ WARNING

FIRE, EXPLOSION, ELECTRICAL SHOCK, AND CARBON MONOXIDE POISONING HAZARD

Failure to follow this warning could result in personal injury or death.

This conversion kit shall be installed by a qualified service agency in accordance with the manufacturer's instructions and all applicable codes and requirements of the authority having jurisdiction. If the information in these instructions is not followed exactly, a fire, explosion, or production of carbon monoxide could result causing property damage, personal injury, or loss of life. The qualified service agency is responsible for the proper installation of this furnace with this kit. The installation is not proper and complete until the operation of the converted appliance is checked as specified in the manufacturer's instructions supplied with the kit.

⚠ AVERTISSEMENT

LE FEU, L'EXPLOSION, CHOC ELECTRIQUE, ET MONOXYDE DE CARBONE EMPOISONNER

Cette trousse de conversion doit être installée par un service d'entretien qualifié, selon les instructions du fabricant et selon toutes les exigences et tous les codes pertinents de l'autorité compétente. Assurez-vous de bien suivre les instructions dans cette notice pour réduire au minimum le risque d'incendie, d'explosion ou la production de monoxyde de carbone pouvant causer des dommages matériels, de blessure ou la mort. Le service d'entretien qualifié est responsable de l'installation de cette trousse. L'installation n'est pas adéquate ni complète tant que le bon fonctionnement de l'appareil converti n'a pas été vérifié selon les instructions du fabricant fournies avec la trousse.

Installing and servicing heating equipment can be hazardous due to gas and electrical components. Only trained and qualified personnel should install, repair, or service heating equipment.

Untrained personnel can perform basic maintenance functions such as cleaning and replacing air filters. Trained service personnel must perform all other operations. When working on heating equipment, observe precautions in the literature, on tags, and on labels attached to or shipped with the unit, and other safety precautions that may apply.

Follow all safety codes. In the United States, follow all safety codes including the current edition of the National Fuel Gas Code (NFGC) NFPA No. 54/ANSI Z223.1. In Canada, refer to the current edition of the National Standard of Canada, Natural Gas and Propane Installation Codes (NSCNGPIC), CAN/CSA-B149.1 and .2. Wear safety glasses and work gloves. Have a fire extinguisher available during start-up, adjustment steps, and service calls.

Recognize safety information. This is the safety-alert symbol ⚠. When you see this symbol on the furnace and in instructions or manuals, be alert to the potential for personal injury. Understand the signal words DANGER, WARNING, CAUTION and NOTE. The words DANGER, WARNING, and CAUTION are used with the safety alert symbol. DANGER identifies the most serious hazards which **will** result in severe personal injury or death. WARNING signifies a hazard which **could** result in personal injury or death. CAUTION is used to identify unsafe practices which **may** result in minor personal injury or product and property damage. NOTE is used to highlight suggestions which **will** result in enhanced installation, reliability, or operation.

INTRODUCTION

⚠ WARNING

FIRE, EXPLOSION, ELECTRICAL SHOCK AND CARBON MONOXIDE POISONING HAZARD

Failure to follow instructions could result in personal injury, death or property damage.

Improper installation, adjustment, alteration, service, maintenance, or use can cause carbon monoxide poisoning, explosion, fire, electrical shock, or other conditions, which could result in personal injury or death. Consult your distributor or branch for information or assistance. The qualified installer or agency must use only factory-authorized kits or accessories when servicing this product.

WARNING

FIRE, EXPLOSION, ELECTRICAL SHOCK HAZARD

Failure to follow this warning could result in personal injury, death or property damage.

Gas supply **MUST** be shut off before disconnecting electrical power and proceeding with conversion.

WARNING

ELECTRICAL SHOCK, FIRE OR EXPLOSION HAZARD

Failure to follow this warning could result in personal injury, death or property damage.

Before installing, modifying, or servicing system, main electrical disconnect switch must be in the OFF position and install a lockout tag. There may be more than one disconnect switch. Lock out and tag switch with a suitable warning label. Verify proper operation after servicing.

This instruction covers the installation of gas conversion kit to convert the 59SC5A026, 59SP5A026, 915S026, 925S026 and PG95S026 furnaces from natural gas usage to propane gas usage.

CAUTION

UNIT OPERATION HAZARD

Failure to follow this caution may result in unit damage or improper operation.

Do not use this kit with other model furnaces with an input other than 26,000 BTUH. If used on furnaces with inputs other than 26,000 BTUH, the unit will be severely under-fired. This could result in delayed ignition, sooting or premature heat exchanger failure from corrosion.

Table 1 – KIT Contents

| QTY. | DESCRIPTION |
|------|------------------------------------|
| 1 | VALVE CONVERSION KIT |
| 7 | 1.25 MM ORIFICES, LH32DB209 |
| 7 | MIXER SCREW |
| 1 | CONNECTOR – BRASS 1/8" NPT X2" |
| 1 | CONNECTOR-SPLC 3/16" |
| 1 | CONNECTOR-1/4QC ME BOTH ENDS |
| 1 | ELBOW, STREET 150 1/8-IN NPT |
| 1 | ELBOW, STREET, BRASS 1/8-IN NPT |
| 1 | NIPPLE – HEX (BRASS) |
| 1 | SWITCH, PRESSURE |
| 1 | TEE – MALE BRANCH (BRASS) |
| 1 | TEE, STREET – MALE BRANCH (BRASS) |
| 1 | 7/64-IN. DRILL BIT |
| 1 | WIRE ASSY – ORANGE |
| 1 | WIRE ASSY – ORANGE |
| 1 | LABEL 342016–201 |
| 1 | LABEL 342016–202 |
| 1 | LABEL 342016–204 |
| 1 | LABEL 342016–205 |

DESCRIPTION AND USAGE

This kit is designed for use with the 59SC5A026, 59SP5A026, 915S026, 925S026 and PG95S026 furnaces. See Table 1 for kit contents. To accommodate many different furnace models, more parts are shipped in kit than will be needed to complete conversion. When installation is complete, discard extra parts.

Table 2 – Condensing Furnaces

| MODEL NUMBERS BEGINNING WITH: | | | | |
|-------------------------------|-------|------|------|-------|
| 59SC5 | 59SP5 | 915S | 925S | PG95S |
| 26,000 Input Only | | | | |

INSTALLATION

1. Set room thermostat to lowest setting or "OFF"
2. Disconnect power at external disconnect, fuse or circuit breaker.
3. Turn off gas at external shut-off or gas meter.
4. Remove outer doors and set aside.
5. Turn electric switch on gas valve to OFF.

MANIFOLD/ORIFICE/BURNER REMOVAL

CAUTION

UNIT OPERATION HAZARD

Failure to follow this caution may result in unit damage or improper operation.

Label all wires prior to disconnection when servicing controls.

PRUDENCE

D'EQUIPEMENT D'OPERATION

Toute erreur de câblage peut être une source de danger et de panne.

Lors des opérations d'entretien des commandes, étiqueter tous les fils avant de les déconnecter.

NOTE: Use a back-up wrench on the gas valve to prevent the valve from rotating on the manifold or damaging the mounting to the burner box.

1. Disconnect the gas pipe from gas valve and remove pipe from the furnace casing. See **Figure 1**.
2. Disconnect the connector harness from gas valve. Disconnect wires from Hot Surface Igniter (HSI) and Flame Sensor.
3. Support the manifold and remove the 4 screws that secure the manifold assembly to the burner box and set aside.
4. Note the location of the green/yellow wire ground wire for re-assembly later. See **Figure 2**.
5. Slide one-piece burner assembly out of slots on sides of burner box.
6. Remove the flame sensor from the burner assembly.
7. Remove the orifices from the manifold and discard.

ORIFICE SELECTION/DERATE

⚠ CAUTION

UNIT DAMAGE HAZARD

Failure to follow this caution may result in unit damage.

DO NOT re-drill burner orifices. Improper drilling may result in burrs, out-of-round holes, etc. Obtain new orifices if orifice size must be changed. (See **Figure 4**)

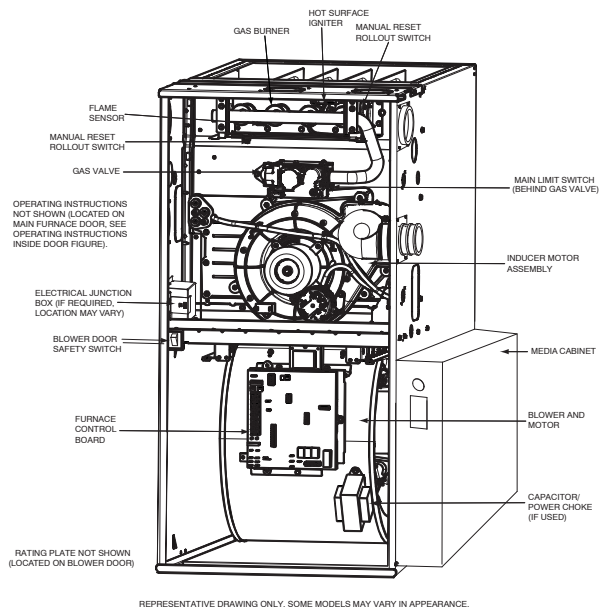

Figure 1 – Representative Furnace Drawing

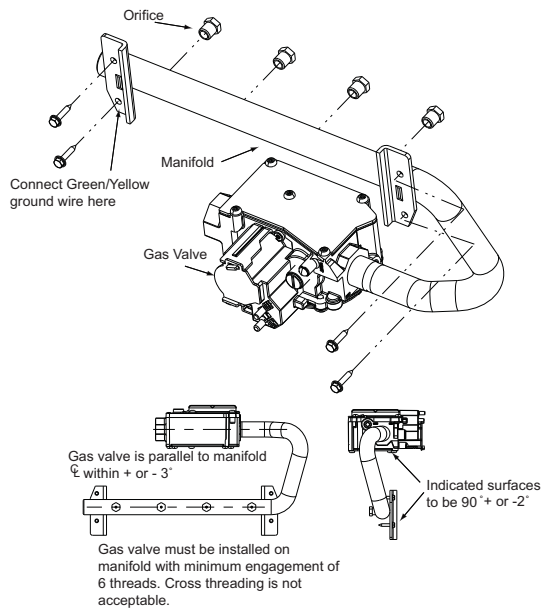

Figure 2 – Manifold Assembly

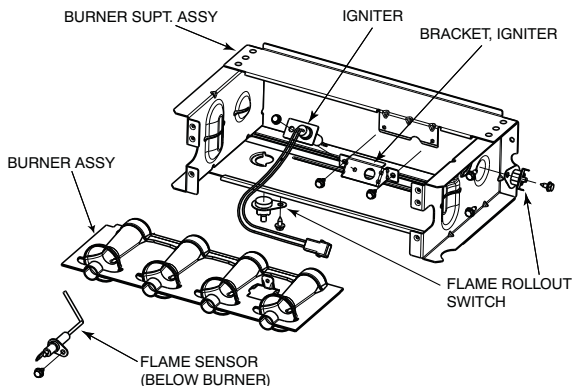

Figure 3 – Burner Assembly

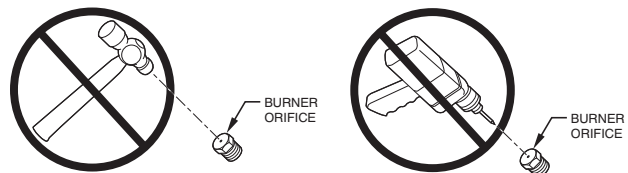

Figure 4 – Burner Orifice

Refer to conversion kit rating plate 342014-201 to determine main burner orifice size. (See **Figure 14**)

Furnace gas input rate on furnace rating plate is for installations at altitudes up to 2000 ft. (610 M).

In the U.S.A.; the input rating for altitudes above 2000 ft. (610 M) must be reduced by 2 percent for each 1000 ft. (305 M) above sea level.

In Canada, the input rating must be derated by 5 percent for altitudes of 2000 ft. to 4500 ft. (610 M to 1372 M) above sea level.

The Conversion Kit Rating Plate accounts for high altitude derate.

INSTALL ORIFICES

1. Install main burner orifices. Do not use Teflon tape. Finger-tighten orifices at least one full turn to prevent cross-threading, then tighten with wrench.
2. There are enough orifices in each kit for largest furnace. Discard extra orifices.

NOTE: DO NOT reinstall the manifold at this time.

INSTALL MIXER SCREWS

NOTE: Use only the parts in the bag marked “**REQUIRED FOR THE CONVERSION OF CONDENSING GAS FURNACES TO PROPANE GAS**”

| 337932-701 | | |
|---|--------------------------|-----|
| PART # | CONTAINS: DESCRIPTION | QTY |
| 328456-402 | BIT, DRILL | 1 |
| FAJ5812B | SCREW | 7 |
| REQUIRED FOR CONVERSION OF CONDENSING GAS FURNACE TO PROPANE GAS. | | |

Figure 5 – Gas Conversion Kit

1. See **Figure 5** to verify you have the correct set of mixer screws.
2. Locate the dimple on each burner venturi tube.
3. If you cannot locate the dimple, refer to **Figure 6** for location of the mixer screw.
4. Drill a 7/64-in (2.8 mm) hole in each dimple with a supplied drill bill.
5. Install a mixer screw in each drilled hole drilling as straight as possible (i.e. in the center of the gas flow stream as well as perpendicular to the gas flow stream).
6. The screw head should be flush with the top of the burner venturi.

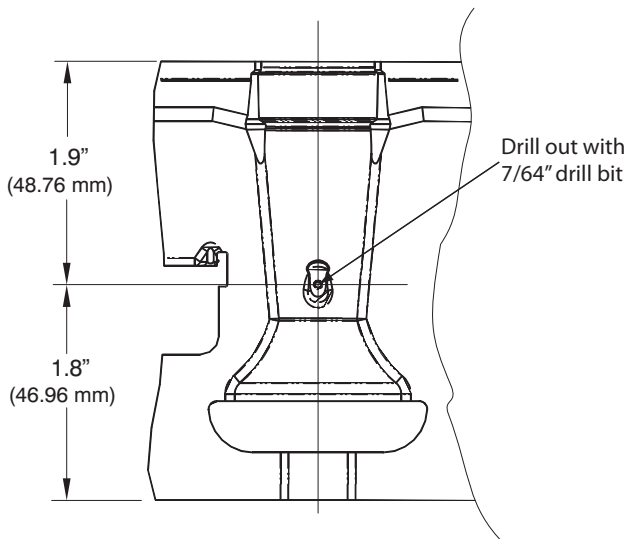

Figure 6 – Mixer Screw Location

A11460

REINSTALL BURNER ASSEMBLY

To reinstall burner assembly:

1. Attach flame sensor to burner assembly.
2. Insert one-piece burner in slot on sides of burner box and slide burner back in place.
3. Reattach HSI wires to HSI.
4. Verify igniter to burner alignment. See **Figure 7** & **Figure 8**.

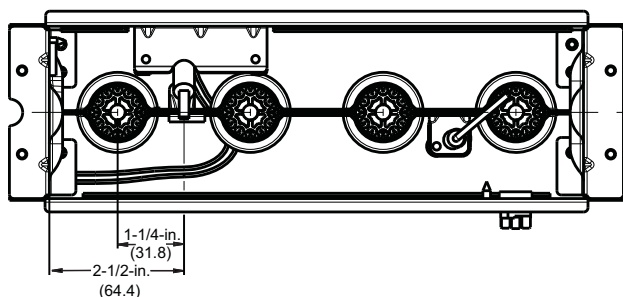
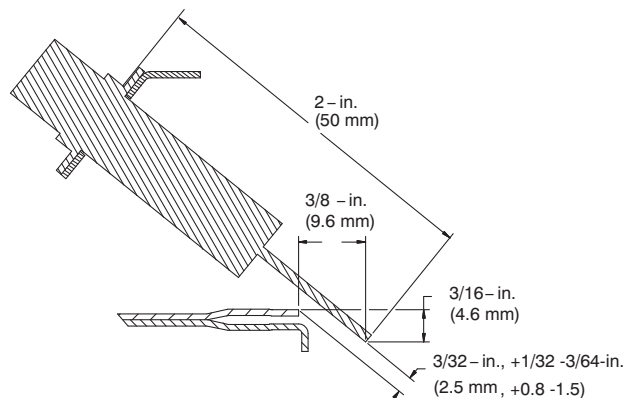

Figure 7 – Igniter Position – Back View

A11405



A12932

Figure 8 – Igniter Position – Side View

CONVERT GAS VALVE

⚠ CAUTION

UNIT DAMAGE HAZARD

Failure to follow this caution may result in unit damage

The gas valve must be pre-adjusted before operating on propane gas. If not pre-adjusted, sooting and corrosion will occur leading to early heat exchanger failure.

⚠ WARNING

FIRE, EXPLOSION, ELECTRICAL SHOCK HAZARD

Failure to follow this warning could result in personal injury, death or property damage.

Gas supply **MUST** be shut off before disconnecting electrical power and proceeding with conversion.

⚠ WARNING

ELECTRICAL SHOCK, FIRE OR EXPLOSION HAZARD

Failure to follow this warning could result in personal injury, death or property damage.

Before installing, modifying, or servicing system, main electrical disconnect switch must be in the OFF position and install a lockout tag. There may be more than one disconnect switch. Lock out and tag switch with a suitable warning label. Verify proper operation after servicing.

NOTE: The green labeled Low Capacity single-stage gas valve **DOES NOT** need to have the regulator spring replaced in the gas valve. The regulator in the gas valve must be pre-adjusted for propane applications. An identical regulator spring is included in the kit to be used in the event the factory spring is unnecessarily removed and misplaced during the propane conversion. The regulator spring is red in color to distinguish it from other regulator springs.

1. Refer to **Figure 9**.
2. Be sure gas and electrical supplies to furnace are off.
3. Remove the brass cap that conceals adjustment screw for the gas–valve regulator. (See **Figure 9**)
4. Turn the regulator adjustment screw 1.5 full turns. This will adjust the valve closer to the propane set point.
5. Do not install the brass regulator seal cap at this time
6. If the red regulator spring is removed, install the spring and the adjustment screw.
7. Turn the adjusting screw clockwise (in) 11.5 full turns. This will increase the manifold pressure closer to the propane set point.
8. Do not install the brass regulator seal cap at this time.

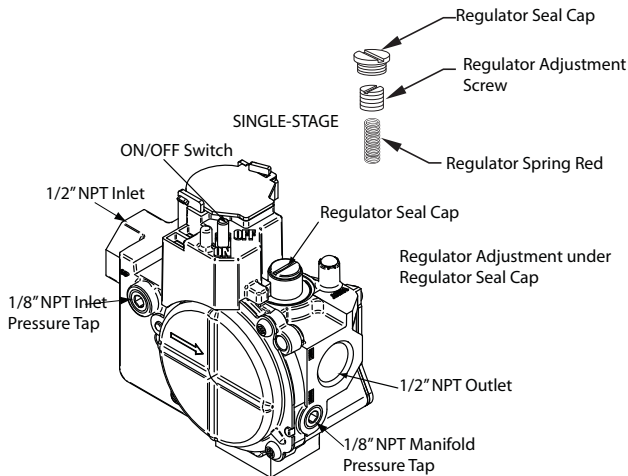

A150593

Single–Stage Gas Valve without Tower Pressure Ports

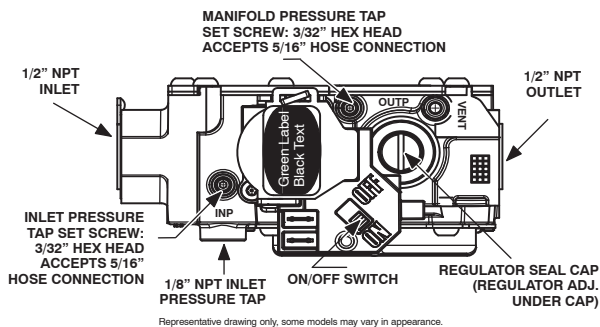

A170140

Figure 9 – Single–Stage Gas Valve with Tower Pressure Ports

INSTALL LOW GAS PRESSURE SWITCH

NOTE: Install the Low Gas Pressure Switch before installing the manifold on the burner assembly.

1. Remove the 1/8-in. NPT pipe plug from the gas valve inlet pressure tap.

NOTE: Use pipe dope approved for use with Propane Gas.

NOTE: Tighten all fittings and the Low Gas Pressure Switch with a small wrench. Do not over-tighten, check for gas leaks after gas supply has been turned on.

⚠ WARNING

FIRE AND EXPLOSION HAZARD

Failure to follow this warning could result in personal injury, death, and/or property damage.

NEVER test for gas leaks with an open flame. Use a commercially available soap solution made specifically for the detection of leaks to check all connections. A fire or explosion may result causing property damage, personal injury or loss of life.

⚠ AVERTISSEMENT

RISQUE D'EXPLOSION ET D'INCENDIE

Cet avertissement peut entraîner de la mort, des blessures et/ou des dégâts matériels.

Ne jamais examiner pour les fuites de gaz avec une flamme vive. Utilisez plutôt un savon fait spécifiquement pour la détection des fuites de gaz pour vérifier tous les connexions. Un incendie ou une explosion peut entraîner des dommages matériels, des blessures ou la mort.

2. Apply pipe dope sparingly to the male threads of the 1/8-in. black iron street elbow. Install the street elbow into the gas valve inlet pressure tap. The opening should be pointing toward you.
3. Apply pipe dope sparingly to the male threads of the 1/8-in. brass street tee. Install the male end of the street tee as shown in **Figure 10**. One opening on the street tee should face you. The other opening should be parallel with the inlet of the gas valve.
4. Apply pipe dope sparingly to the male threads of the 1/8-in. brass hex nipple. Install the hex nipple into the open end of the brass street tee. See **Figure 10**. The hex nipple should be parallel with the boss on the gas valve.
5. Install the open end of the brass street elbow on the end of the hex nipple. Tighten the street elbow so the male threads of the elbow point away from you.
6. Apply pipe dope sparingly to the male threads of the 1/8-in. brass street elbow. Install the Low Gas Pressure Switch on the male threads of the street elbow. Tighten switch at hex fitting at base of switch. Do not use switch body to tighten switch. Do not over-tighten switch.
7. The remaining opening on the brass street tee is the new gas valve inlet pressure tap (optional on some models). Apply pipe dope to inlet pressure plug from gas valve and install in open end of brass street tee.

8. Check all fittings for leaks after gas supply has been turned on.

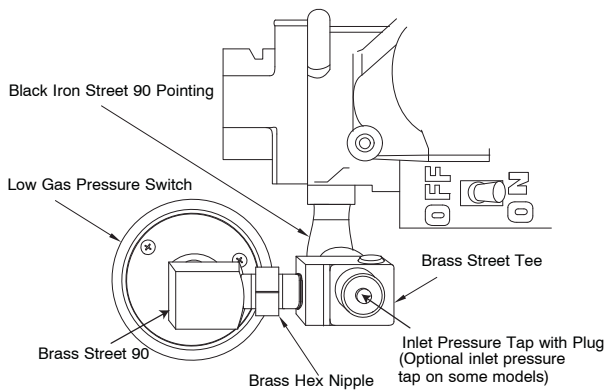

A170141

Figure 10 – Low Gas Pressure Switch Removal

INSTALL LOW GAS PRESSURE SWITCH WIRES

1. Locate the orange wire in the kit with an insulated straight female spade terminal and an insulated straight male terminal on the other end.
2. Connect the female terminal to a terminal on the Low Gas Pressure Switch.
3. Locate the orange wire in kit with an insulated straight female spade terminal and an insulated female flag terminal on the other end.
4. Connect both straight female terminals of the orange wires to the terminals on the Low Gas Pressure Switch.

INSTALL MANIFOLD

1. Refer to **Figure 2** and **Figure 3**.
2. Align the orifices in the manifold assembly with the support rings on the end of the burner.
3. Insert the orifices in the support rings of the burners. Manifold mounting tabs should fit flush against the burner box.

NOTE: If manifold does not fit flush against the burner box, the burners are not fully seated forward. Remove the manifold and check burner positioning in the burner box assembly.

4. Attach the green/yellow wire and ground terminal to one of the manifold mounting screws. See **Figure 2**.
5. Install the remaining manifold mounting screws.
6. Connect the wires to the flame sensor and hot surface igniter.
7. Connect the connector harness to gas valve.

NOTE: Use only propane-resistant pipe dope. Do not use Teflon tape.

8. Insert the gas pipe through the grommet in the casing. Apply a thin layer of pipe dope to the threads of the pipe and thread the pipe by into the gas valve.

NOTE: Use a back-up wrench on the gas valve to prevent the valve from rotating on the manifold or damaging the mounting to the burner box.

9. With a back-up wrench on the inlet boss of the gas valve, finish tightening the gas pipe to the gas valve.
10. Turn gas on at electric switch on gas valve.

MODIFY PRESSURE SWITCH WIRING

⚠ CAUTION

UNIT OPERATION HAZARD

Failure to follow this caution may result in unit damage or improper operation.

Label all wires prior to disconnection when servicing controls.

⚠ PRUDENCE

D'EQUIPEMENT D'OPERATION

Toute erreur de câblage peut être une source de danger et de panne.

Lors des opérations d'entretien des commandes, étiqueter tous les fils avant de les déconnecter.

1. Disconnect orange wire from Low Heat Pressure Switch LPS on inducer housing. See **Figure 1**.
2. Connect the orange wire from the Low Heat Pressure Switch to the orange wire with the insulated male spade terminal. See **Figure 11**.
3. Connect the orange wire with the flag terminal on the Low Gas Pressure Switch to the terminal on the Low Heat Pressure Switch.
4. Route orange wires along wire harness. If possible, secure with wire tie provided in kit.

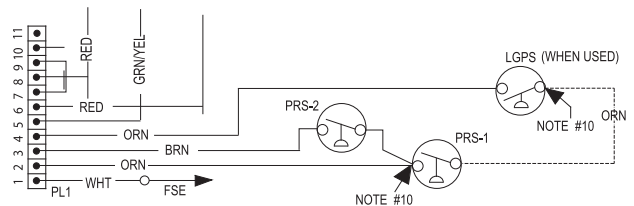

A12372

Figure 11 – Pressure Switch Wiring

CHECK INLET GAS PRESSURE

⚠ CAUTION

UNIT DAMAGE HAZARD

Failure to follow this caution may result in unit damage.

DO NOT operate furnace more than one minute to check inlet gas pressure, as conversion is not complete at this time.

NOTE: This kit is to be used only when inlet gas pressure is between 12.0-in. W.C. and 13.6-in. W.C.

1. On some models, remove 1/8-in. (3 mm) pipe plug from inlet pressure tap on the inlet end of gas valve (see **Figure 10**) and insert pressure tap. Or, on some models, loosen set screw on inlet tower pressure tap no more than one full turn with the 3/32-in. hex wrench. (See **Figure 9**)

2. Verify manometer is connected to inlet pressure tap on gas valve. (See **Figure 9**)
3. Turn on furnace power supply.
4. Turn gas supply manual shutoff valve to ON position.

WARNING

FIRE, EXPLOSION, ELECTRICAL SHOCK HAZARD

Failure to follow this warning could result in personal injury, death or property damage.

Gas supply **MUST** be shut off before disconnecting electrical power and proceeding with conversion.

WARNING

ELECTRICAL SHOCK, FIRE OR EXPLOSION HAZARD

Failure to follow this warning could result in personal injury, death or property damage.

Before installing, modifying, or servicing system, main electrical disconnect switch must be in the OFF position and install a lockout tag. There may be more than one disconnect switch. Lock out and tag switch with a suitable warning label. Verify proper operation after servicing.

5. Turn furnace gas valve switch to ON position.
6. Jumper R–W thermostat connections on control.
7. When main burners ignite, confirm inlet gas pressure is between 12.0–in. W.C. and 13.6–in. W.C.
8. Remove jumper across R–W thermostat connections to terminate call for heat.
9. Turn furnace gas valve switch to OFF position.
10. Turn gas supply manual shutoff valve to OFF position.
11. Turn off furnace power supply.
12. Remove manometer and on some models remove pressure tap fitting.
13. On some models, apply pipe dope sparingly to the end of inlet gas pipe plug and install into unused end of 1/8–in. (3 mm) tee. Use a small back–up wrench on tee when tightening gas inlet pipe plug. Or, on some models, tighten set screw on inlet tower pressure tap with a 3/32–in. hex wrench. (See **Figure 9**)

CHECK FURNACE AND MAKE ADJUSTMENTS

WARNING

FIRE AND EXPLOSION HAZARD

Failure to follow this warning could result in personal injury, death, and/or property damage.

NEVER test for gas leaks with an open flame. Use a commercially available soap solution made specifically for the detection of leaks to check all connections. A fire or explosion may result causing property damage, personal injury or loss of life.

AVERTISSEMENT

RISQUE D'EXPLOSION ET D'INCENDIE

Cet avertissement peut entraîner de la mort, des blessures et/ou des dégâts matériels.

Ne jamais examiner pour les fuites de gaz avec une flamme vive. Utilisez plutôt un savon fait spécifiquement pour la détection des fuites de gaz pour vérifier tous les connexions. Un incendie ou une explosion peut entraîner des dommages matériels, des blessures ou la mort.

1. Be sure main gas and electric supplies to furnace are off.
2. On some models, remove 1/8-in. (3 mm) pipe plug from manifold pressure tap on the outlet end of gas valve and insert pressure tap. Or, on some models, loosen set screw on manifold tower pressure tap no more than one full turn with a 3/32–in. hex wrench.
3. Attach manometer to manifold pressure tap on gas valve. (see **Figure 9**)
4. Turn gas supply manual shutoff valve to ON position.
5. Turn furnace gas valve switch to ON position.
6. Check all threaded pipe connections for gas leaks.
7. Turn on furnace power supply.

GAS INPUT RATE INFORMATION

The gas input rate for propane is the same as for natural gas. See furnace rating plate (see **Figure 14**) for input rate. The input rate for propane is determined by manifold pressure and orifice size.

Furnace gas input rate on rating plate is for installations at altitudes up to 2000 ft. (610 M).

In the U.S.A.; the input rating for altitudes above 2000 ft. (610M) must be reduced by 2 percent for each 1000 ft. (305 M) above sea level.

In Canada; the input rating must be derated by 5 percent for altitudes of 2000 ft. (610 M) to 4500 ft. (1372 M) above sea level.

The Conversion Kit Rating Plate accounts for high altitude derate.

SET GAS INPUT RATE

1. Jumper R and W thermostat connections to call for heat. (See **Figure 12**)
2. Check manifold orifices for gas leaks when main burners ignite.
3. Adjust gas manifold pressure.
4. Remove cap that conceals gas valve regulator adjustment screw.
5. Turn adjusting screw counterclockwise (out) to decrease manifold pressure or clockwise (in) to increase manifold pressure.
6. Replace gas valve regulator seal cap.
7. Verify manifold pressure is correct.

NOTE: Gas valve regulator seal cap **MUST** be in place when checking input rate. When correct input is obtained, main burner flame should be clear blue, almost transparent (See **Figure 13**). Be sure regulator seal cap is in place when finished.

8. Remove jumper across R and W thermostat connections to terminate call for heat.

9. Turn furnace gas valve control switch or control knob to OFF position.
10. Turn off furnace power supply.
11. Remove manometer and on some models remove pressure tap fitting.
12. On some models, apply pipe dope sparingly to end of 1/8-in. (3 mm) pipe plug and install in the manifold pressure tap opening. Or, on some models, tighten set screw on manifold tower pressure tap with a 3/32-in. hex wrench. See **Figure 9**.
13. Turn furnace gas-valve switch to ON position.
14. Turn on furnace power supply.
15. Set room thermostat to call for heat.
16. Check pressure tap plug for gas leaks when main burners ignite.
17. Check for correct burner flame.
18. After making the required manifold pressure adjustments, check and adjust the furnace temperature rise per the furnace installation instructions.

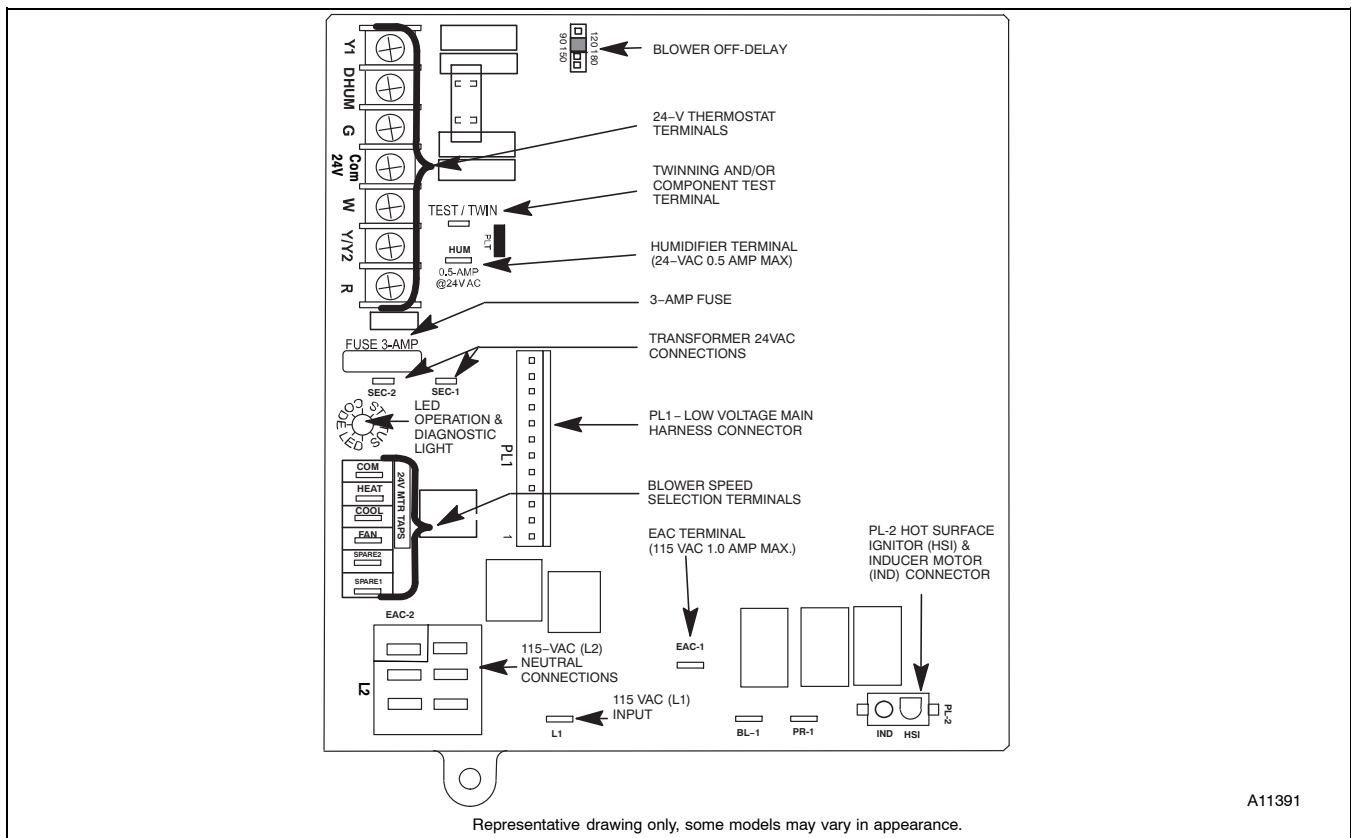

Figure 12 - Single-Stage Furnace Control

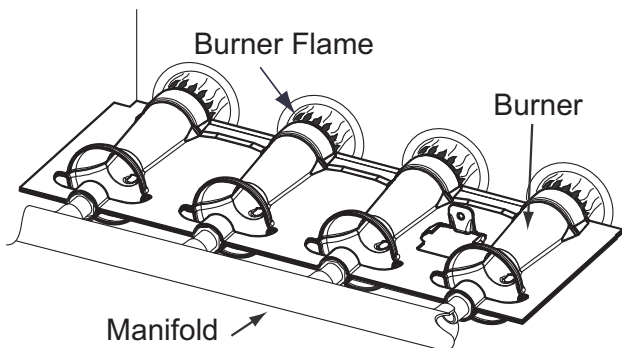

Figure 13 - Burner Flame

CHECK LOW GAS PRESSURE SWITCH

The newly installed low gas pressure switch is a safety device used to guard against adverse burner operating characteristics that can result from low gas supply pressure. Switch opens at not less than 7.2 in. W.C. and closes at not greater than 10.2 in. W.C.

This switch also prevents operation when the propane tank level is low which can result in gas with a high concentration of impurities, additives, and residues that have settled to the bottom of the tank. Operation under these conditions can cause harm to the heat exchanger

system. This normally open switch closes when gas is supplied to gas valve under normal operating pressure.

The closed switch completes control circuit. Should an interruption or reduction in gas supply occur, the gas pressure at switch drops below low gas pressure switch setting, and switch opens. Any interruption in control circuit (in which low gas pressure switch is wired) quickly closes gas valve and stops gas flow to burners. When normal gas pressure is restored, the system must be electrically reset to re-establish normal heating operation.

Before leaving installation, observe unit operation through two complete heating cycles. During this time, turn gas supply to gas valve off just long enough to completely extinguish burner flame, then instantly restore full gas supply. To ensure proper low gas pressure switch operation, observe that there is no gas supply to burners until after hot surface igniter begins glowing.

LABEL APPLICATION

1. Fill in Conversion Responsibility Label 342014–205 (see **Figure 14**) and apply to blower door of furnace

as shown. Date, name, and address of organization making this conversion are required.

2. Attach Conversion Rating Plate Label 342014–201 to outer door of furnace.
3. Apply Gas Control Conversion Label to gas valve: For single-stage gas valve apply label 342014–202 to gas valve. (Do not use 342014–203, which is similar) Check for correct normal operating sequence of the ignition system as described in furnace Installation, Start-Up, and Operating Instructions.
4. Replace control access door, blower door and outer door of furnace.

CHECKOUT

1. Observe unit operation through two complete heating cycles.
2. See Sequence of Operation in furnace Installation, Start-Up, and Operating Instructions.
3. Set room thermostat to desired temperature.

CONVERSION KIT RATING PLATE - CARRIER CORPORATION

THIS APPLIANCE HAS BEEN CONVERTED TO USE PROPANE GAS FOR FUEL. REFER TO KIT INSTRUCTIONS FOR CONVERSION PROCEDURES. USE PARTS SUPPLIED BY CARRIER CORPORATION AND INSTALLED BY QUALIFIED PERSONNEL. SEE EXISTING RATING PLATE FOR APPLIANCE MODEL NO. AND INPUT RATING.

NOTE: Furnace gas input rate on rating plate is for installations up to 2000 ft. (610m) above sea level. In U.S.A. the input rating for altitudes above 2000 ft. (610m) must be derated by 2% for each 1000 ft. (305m) above sea level. In Canada the input rating must be derated by 5% for altitudes of 2000 ft. (610m) to 4500 ft. (1372m) above sea level.

KIT NO.: KGANP54011SP
(SUPERSEDES: NONE)

FUEL USED: PROPANE GAS

INLET PRESSURE (min - max): 12.0 - 13.6 in. wc

| APPLIANCE MODELS | Orifice No. | ALTITUDE OF INSTALLATION (FT. ABOVE SEA LEVEL) U.S.A. * | | | | | | | | | |
|---|-------------------|---|----------------|--------------|--------------|--------------|--------------|--------------|--------------|---------------|--------|
| | | 0 to 2000 | 2001 * to 3000 | 3001 to 4000 | 4001 to 5000 | 5001 to 6000 | 6001 to 7000 | 7001 to 8000 | 8001 to 9000 | 9001 to 10000 | |
| 26K INPUT UNITS ONLY 59SC5, 59SP5, 915S, 925S, PG95S | | 1.25mm | 1.25mm | 1.25mm | 1.25mm | 1.25mm | 1.25mm | 1.25mm | 1.25mm | 1.25mm | 1.25mm |
| | MANIFOLD PRESSURE | | | | | | | | | | |
| | | 5.5 | 5.5 | 5.4 | 5.4 | 5.4 | 5.3 | 5.3 | 5.2 | 5.2 | |

* For Canadian Installations from 2000 to 4500 ft. (610m to 1373m) use U.S.A. column 2001 to 3000 ft. (611m to 914m).

342014-201 REV. A

This control has been adjusted for use with propane gas.
Ce contrôle a été réglé pour fonctionner au gaz propane.

342014-202 REV. A

LABEL NOT USED

PLAQUE SIGNALÉTIQUE DE LA TROUSSE DE CONVERSION - CARRIER CORPORATION

CET APPAREIL A ÉTÉ CONVERTI POUR UNE COMBUSTION AU GAZ PROPANE. SE RÉFÉRER AUX INSTRUCTIONS DE L'ÉQUIPEMENT POUR LES PROCÉDURES DE CONVERSION. N'UTILISER QUE DES PIÈCES FOURNIES PAR LA CORPORATION CARRIER ET INSTALLÉES PAR DU PERSONNEL QUALIFIÉ. VOIR LA PLAQUE SIGNALÉTIQUE EXISTANTE POUR LE MODÈLE D'APPAREIL ET LA CONSOMMATION.

REMARQUE: Le débit d'entrée du gaz de la fournaise indiqué sur la plaque signalétique s'applique aux installations jusqu'à 610m (2000 pieds) au-dessus du niveau de la mer. Aux États-Unis, le débit d'entrée pour les altitudes au-dessus de 610m (2000 pieds) doit être réduit de 2% pour chaque 305m (1000 pieds) au-dessus du niveau. Au Canada, le débit d'entrée doit être réduit par 5% pour les altitudes de 2000 pieds à 4500 pieds au-dessus du niveau de la mer.

KIT NO.: KGANP54011SP

(SUPPLANT: AUCUN)

COMBUSTIBLE: GAZ PROPANE

PRESSION D'ENTRÉE (min - max): 12.0 - 13.6 po COLONNE D'EAU

| APPROUVÉ POUR LES MODÈLES: | N° Orifice | ALTITUDE DE L'INSTALLATION (PI AU-DESSUS DU NIVEAU DE LA MER) É.U. * | | | | | | | | | |
|--|---------------------|--|----------------|--------------|--------------|--------------|--------------|--------------|--------------|---------------|--------|
| | | 0 to 2000 | 2001 * to 3000 | 3001 to 4000 | 4001 to 5000 | 5001 to 6000 | 6001 to 7000 | 7001 to 8000 | 8001 to 9000 | 9001 to 10000 | |
| 26K UNITÉS ENTRÉE SEULEMENT 59SC5, 59SP5, 915S, 925S, PG95S | | 1.25mm | 1.25mm | 1.25mm | 1.25mm | 1.25mm | 1.25mm | 1.25mm | 1.25mm | 1.25mm | 1.25mm |
| | PRESSION COLLECTEUR | | | | | | | | | | |
| | | 5.5 | 5.5 | 5.4 | 5.4 | 5.4 | 5.3 | 5.3 | 5.2 | 5.2 | |

* Pour les installations au Canada entre 610m et 1373m (2000 to 4500 ft) utiliser la colonne à 611m et 914m (2001 to 3000 ft) des É.U.

342014-204 REV. A

THIS FURNACE WAS CONVERTED
ON _____ TO PROPANE GAS
(DAY-MONTH-YEAR)

KIT NO.: KGANP54011SP

(Name and address of organization making this conversion),
which accepts the responsibility that this conversion has
been properly made.

CE GÉNÉRATEUR D'AIR CHAUD A ÉTÉ
CONVERTI _____ POUR
(JOUR-MOIS-ANNÉE)

DE L'ENSEMBLE N°.: KGANP54011SP

PAR:

(Nom et adresse de l'organisme qui a effectué la conversion),
qui accepte l'entière responsabilité de la conversion.

342014-205 REV. A

342014-701 REV. A

Figure 14 – Conversion Kit Labels

A150528