

# Installation Instructions



**NOTE:** Read the entire instruction manual before starting the installation.

## **SAFETY CONSIDERATION**

**⚠ WARNING**

**FIRE, EXPLOSION, ELECTRICAL SHOCK, AND CARBON MONOXIDE POISONING HAZARD**

Failure to follow this warning could result in personal injury or death.

This conversion kit shall be installed by a qualified service agency in accordance with the manufacturer’s instructions and all applicable codes and requirements of the authority having jurisdiction. If the information in these instructions is not followed exactly, a fire, explosion, or production of carbon monoxide could result causing property damage, personal injury, or loss of life. The qualified service agency is responsible for the proper installation of this furnace with this kit. The installation is not proper and complete until the operation of the converted appliance is checked as specified in the manufacturer’s instructions supplied with the kit.

**⚠ AVERTISSEMENT**

**LE FEU, L’EXPLOSION, CHOC ELECTRIQUE, ET MONOXYDE DE CARBONE EMPOISONNER**

Cette trousse de conversion doit être installée par un service d’entretien qualifié, selon les instructions du fabricant et selon toutes les exigences et tous les codes pertinents de l’autorité compétente. Assurez-vous de bien suivre les instructions dans cette notice pour réduire au minimum le risque d’incendie, d’explosion ou la production de monoxyde de carbone pouvant causer des dommages matériels, de blessure ou la mort. Le service d’entretien qualifié est responsable de l’installation de cette trousse. L’installation n’est pas adéquate ni complète tant que le bon fonctionnement de l’appareil converti n’a pas été vérifié selon les instructions du fabricant fournies avec la trousse.

Installing and servicing heating equipment can be hazardous due to gas and electrical components. Only trained and qualified personnel should install, repair, or service heating equipment.

Untrained personnel can perform basic maintenance functions such as cleaning and replacing air filters. Trained service personnel must perform all other operations. When working on heating equipment, observe precautions in the literature, on tags, and on labels attached to or shipped with the unit, and other safety precautions that may apply.

Follow all safety codes. In the United States, follow all safety codes including the current edition of the National Fuel Gas Code (NFGC) NFPA No. 54/ANSI Z223.1. In Canada, refer to the current edition of the National Standard of Canada, Natural Gas and Propane Installation Codes (NSCNGPIC), CAN/CSA–B149.1 and .2. Wear safety glasses and work gloves. Have a fire extinguisher available during start–up, adjustment steps, and service calls.

Recognize safety information. This is the safety–alert symbol ⚠. When you see this symbol on the furnace and in instructions or manuals, be alert to the potential for personal injury. Understand the signal words DANGER, WARNING, CAUTION and NOTE. The words DANGER, WARNING, and CAUTION are used with the safety alert symbol. DANGER identifies the most serious hazards which **will** result in severe personal injury or death. WARNING signifies a hazard which **could** result in personal injury or death. CAUTION is used to identify unsafe practices which **may** result in minor personal injury or product and property damage. NOTE is used to highlight suggestions which **will** result in enhanced installation, reliability, or operation.

## **INTRODUCTION**

**⚠ WARNING**

**FIRE, EXPLOSION, ELECTRICAL SHOCK AND CARBON MONOXIDE POISONING HAZARD**

Failure to follow instructions could result in personal injury, death or property damage.

Improper installation, adjustment, alteration, service, maintenance, or use can cause carbon monoxide poisoning, explosion, fire, electrical shock, or other conditions, which could result in personal injury or death. Consult your distributor or branch for information or assistance. The qualified installer or agency must use only factory–authorized kits or accessories when servicing this product.

**⚠ WARNING**

**FIRE, EXPLOSION, ELECTRICAL SHOCK HAZARD**

Failure to follow this warning could result in personal injury, death or property damage.

Gas supply **MUST** be shut off before disconnecting electrical power and proceeding with conversion.



# WARNING

## ELECTRICAL SHOCK, FIRE OR EXPLOSION HAZARD

Failure to follow this warning could result in personal injury, death or property damage.

Before installing, modifying, or servicing system, main electrical disconnect switch must be in the OFF position and install a lockout tag. There may be more than one disconnect switch. Lock out and tag switch with a suitable warning label. Verify proper operation after servicing.

This instruction covers the installation of gas conversion kit to convert the following furnaces from Propane gas usage to natural gas usage. See appropriate section for your furnace type.

**Section 1**—59MN7 & 987M 4-Way Multipoise, Hot Surface Ignition, Modulating Condensing Furnaces. 59TN6, 59TP6, 926T, 986T, PG96V\_T, 4-Way Multipoise, Hot Surface Ignition, 2-Stage, Variable-Speed Condensing Furnaces. This kit applies to 40,000 to 120,000 Btuh gas input rates.

**Section 3**—58CTW, 58CTY, 58CVA, 58CVX, 314AAV, 314JAV, 315AAV, 315JAV, PG8MV, PG8JV, 33.3-In. (846 mm) High, Induced-Combustion, Hot-Surface Ignition, 2-Stage, Variable-Speed, Non-Condensing Furnaces. This kit is designed for use in furnaces with 42,000 through 154,000 Btuh gas input rates.

## DESCRIPTION AND USAGE

See **Table 1** for kit contents. This kit is designed for use in the furnaces listed in **Table 6**. To accommodate many different furnace models, more parts are shipped in kit than will be needed to complete conversion. When installation is complete, discard extra parts.

Table 1		Kit Contents
QTY.	PART NUMBER	DESCRIPTION
2	EF39ZW037	VALVE CVRSN KIT - W/R SPRING 92-0659
1	323267-701	BAG ASSEMBLY Includes:
7	LH32DB207	ORIFICE - #42
1	323267-702	BAG ASSEMBLY Includes:
7	LH32DB202	ORIFICE - #43
1	323267-703	BAG ASSEMBLY Includes:
7	LH32DB200	ORIFICE - #44
1	323267-704	BAG ASSEMBLY Includes:
7	LH32DB205	ORIFICE - #45
1	340741-701	LABEL SHEET Includes:
1	340741-201	CONVERSION RATING PLATE
1	340741-202	GAS CONTROL CONVERSION LABEL
1	340741-203	GAS CONTROL ADJUSTMENT LABEL
1	340741-204	CONVERSION RATING PLATE
1	340741-205	CONVERSION RESPONSIBILITY LABEL
1	340741-702	LABEL SHEET Includes:
1	340741-206	CONVERSION RATING PLATE
1	340741-209	CONVERSION RATING PLATE

## SECTION 1

## CONDENSING FURNACES

Table 2		MODEL NUMBERS BEGINNING WITH:
59MN7		987M
59TN6		986T
59TP6		926T
PG96V_T		

## INSTALLATION

1. Set room thermostat to lowest setting or "OFF".
2. Remove outer doors.

3. Disconnect power at external disconnect, fuse or circuit breaker.
4. Turn off gas at external shut-off or gas meter.
5. Remove outer doors and set aside.
6. Turn electric switch on gas valve to OFF.

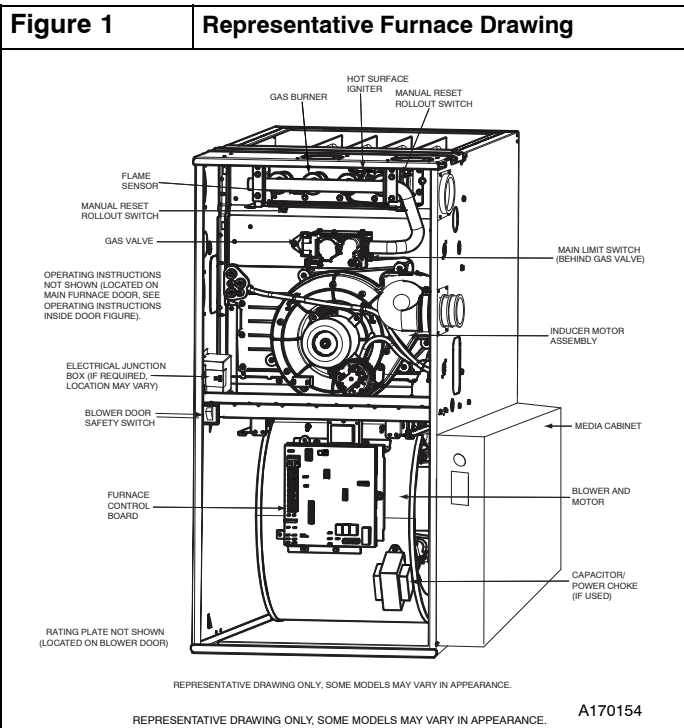

## MANIFOLD/ORIFICE/BURNER REMOVAL



# CAUTION

### UNIT OPERATION HAZARD

Failure to follow this caution may result in unit damage or improper operation.

Label all wires prior to disconnection when servicing controls.



# PRUDENCE

### D'EQUIPEMENT D'OPERATION

Toute erreur de câblage peut être une source de danger et de panne.

Lors des opérations d'entretien des commandes, étiqueter tous les fils avant de les déconnecter.

**NOTE:** Use a back-up wrench on the gas valve to prevent the valve from rotating on the manifold or damaging the mounting to the burner box.

1. Disconnect the gas pipe from gas valve and remove pipe from the furnace casing. (See **Figure 1**)
2. Disconnect the connector harness from gas valve. Disconnect wires from Hot Surface Igniter (HSI) and Flame Sensor. Disconnect the two wires from the low gas pressure switch (LGPS) located on the gas valve.
3. Support the manifold and remove the four (4) screws that secure the manifold assembly to the burner box and set aside.
4. Note the location of the green/yellow wire ground wire for re-assembly later. (See **Figure 2**)
5. Slide one-piece burner assembly out of slots on sides of burner box.

- Remove the flame sensor from the burner assembly. (See **Figure 3**)
- Remove the orifices from the manifold and discard.

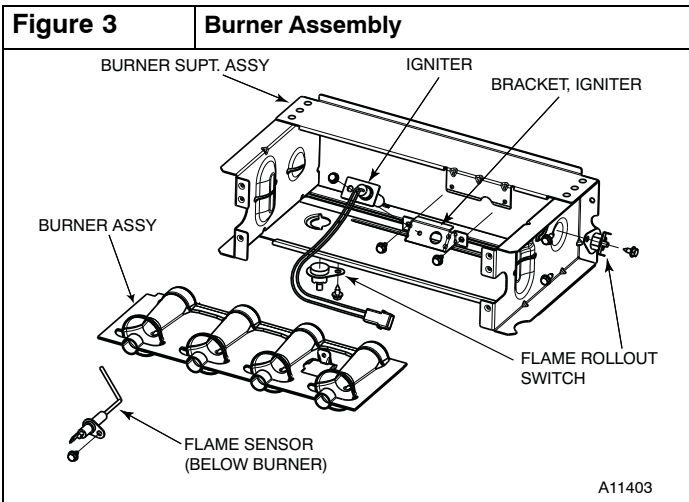
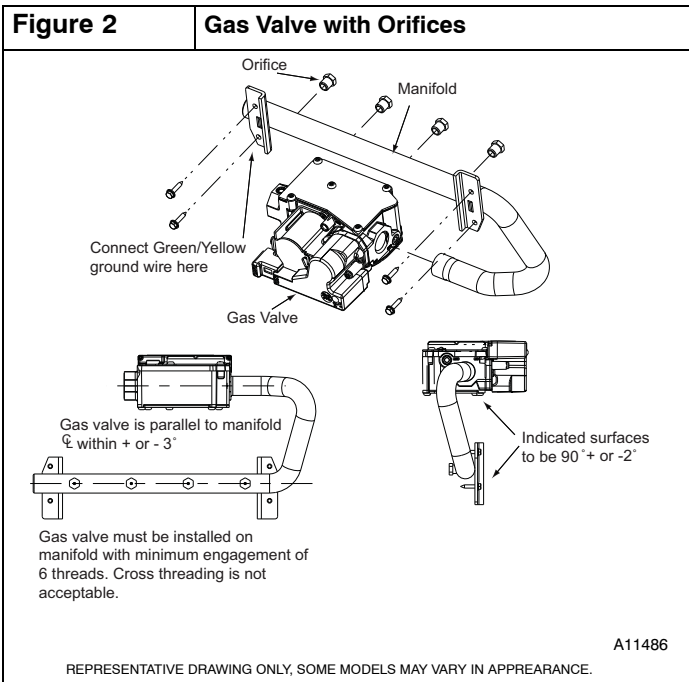

## ORIFICE SELECTION/DERATE

**CAUTION**

**UNIT DAMAGE HAZARD**

Failure to follow this caution may result in unit damage.

DO NOT re-drill burner orifices. Improper drilling may result in burrs, out-of-round holes, etc. Obtain new orifices if orifice size must be changed. (See **Figure 4**)

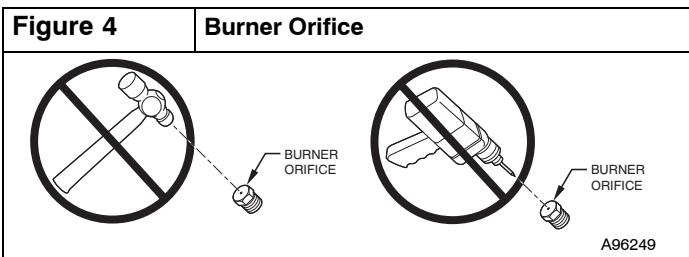

Determine natural gas orifice size and manifold pressures for correct input at installed altitude by using **Table 3** (for 20,000 Btuh/Max-Heat/8,000 Btuh Min-Heat per burner), **Table 4** (for 20,200 Btuh Max-Heat/8,000 Btuh Min-Heat per burner), or **Table 5** (for two-stage gas valve).

- Obtain yearly heat-value average (at installed altitude) for local gas supply.
- Obtain yearly specific-gravity average for local gas supply.
- Find installation altitude in **Table 3**, **Table 4** (depending on furnace gas input rate), or **Table 5**.

**NOTE:** For Canada altitudes of 2000 to 4500 ft., use U.S.A. Altitudes of 2001 to 3000 ft. In **Table 3**, **Table 4**, or **Table 5**.

- Find closest natural gas heat value and specific gravity in **Table 3**, **Table 4**, or **Table 5**.
- Follow heat-value line and specific-gravity line to point of intersection to find orifice size and maximum and minimum manifold pressure settings.

Furnace gas input rate on furnace rating plate is for installations at altitudes up to 2000 ft. (610 M).

**In the U.S.A.;** the input rating for altitudes above 2000 ft. must be reduced by 2 percent for each 1000 ft. above sea level.

**In Canada;** the input rating must be derated by 5 percent for altitudes of 2000 ft. to 4500 ft. above sea level.

The Conversion Kit Rating Plate accounts for high altitude derate.

## INSTALL ORIFICES

- Install main burner orifices. DO NOT use Teflon tape. Finger-tighten orifices at least one full turn to prevent cross-threading, then tighten with wrench.
- There are enough orifices in each kit for largest furnace. Discard extra orifices.

**NOTE:** DO NOT reinstall the manifold at this time.

## REMOVE MIXER SCREWS FROM THE BURNERS

**NOTE:** Each burner contains a mixer screw that must be removed. Refer to **Figure 5** for the mixer screw location.

- Remove the mixer screws from the burners.

**NOTE:** It is not necessary to plug the hole in the burner when the mixer screws are removed.

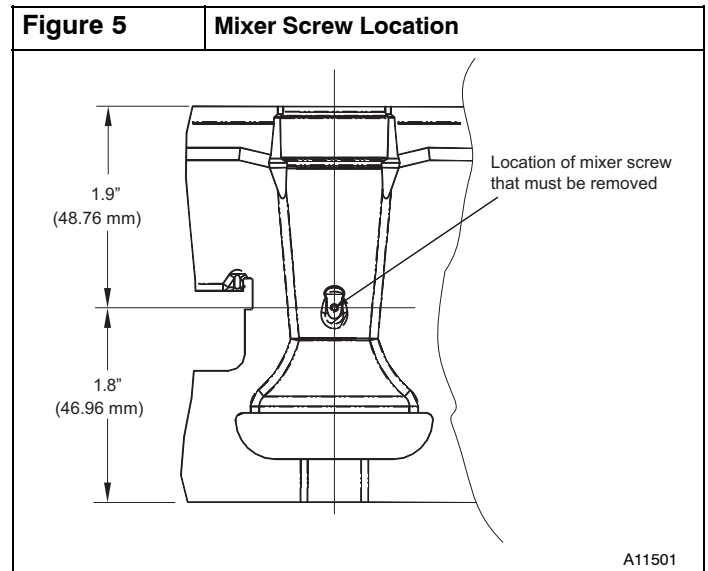

**Table 3 Orifice Size and Manifold Pressure (in. w.c.) for Gas Input Rate**

**TO BE USED WITH MODULATING FURNACES EXCEPT THE EXCEPT 59MN7A060V21-20 and 987MA60060V21**

**MODULATING FURNACE**  
 (TABULATED DATA BASED ON 20,000 BTUH MAX-HEAT / 8,000 BTUH MIN-HEAT PER BURNER,  
 DERATED 2%/1000 FT (305M) ABOVE SEA LEVEL)

ALTITUDE RANGE ft (m)		AVG. GAS HEAT VALUE AT ALTITUDE (Btu/cu ft)	SPECIFIC GRAVITY OF NATURAL GAS							
			0.58		0.60		0.62		0.64	
			Orifice No.	Mnflid Press Max/Min	Orifice No.	Mnflid Press Max/Min	Orifice No.	Mnflid Press Max/Min	Orifice No.	Mnflid Press Max/Min
U.S.A. and Canada	0 (0) to 2000 (610)	900	43	3.8 /0.60	42	3.2 /0.50	42	3.3 /0.55	42	3.4 /0.55
		925	43	3.6 /0.55	43	3.7 /0.60	43	3.8 /0.60	42	3.2 /0.50
		950	43	3.4 /0.55	43	3.5 /0.55	43	3.6 /0.60	43	3.7 /0.60
		975	44	3.7 /0.60	44	3.8 /0.60	43	3.4 /0.55	43	3.6 /0.55
		1000	44	3.5 /0.55	44	3.6 /0.60	44	3.8 /0.60	43	3.4 /0.55
		1025	44	3.3 /0.55	44	3.5 /0.55	44	3.6 /0.55	44	3.7 /0.60
		1050	44	3.2 /0.50	44	3.3 /0.55	44	3.4 /0.55	44	3.5 /0.55
		1075	45	3.7 /0.60	45	3.8 /0.60	44	3.3 /0.50	44	3.4 /0.55
U.S.A. and Canada	2001 (611) to 4500 (1372)	1100	46	3.7 /0.60	46	3.8 /0.60	45	3.8 /0.60	44	3.2 /0.50
		800	42	3.4 /0.55	42	3.5 /0.55	42	3.6 /0.55	42	3.7 /0.60
		825	43	3.8 /0.60	42	3.3 /0.50	42	3.4 /0.55	42	3.5 /0.55
		850	43	3.6 /0.60	43	3.7 /0.60	42	3.2 /0.50	42	3.3 /0.55
		875	43	3.4 /0.55	43	3.5 /0.55	43	3.7 /0.60	43	3.8 /0.60
		900	44	3.7 /0.60	44	3.8 /0.60	43	3.5 /0.55	43	3.6 /0.55
		925	44	3.5 /0.55	44	3.6 /0.60	44	3.8 /0.60	43	3.4 /0.55
		950	44	3.3 /0.55	44	3.4 /0.55	44	3.6 /0.55	44	3.7 /0.60
U.S.A. Only	3001 (915) to 4000 (1219)	975	44	3.2 /0.50	44	3.3 /0.50	44	3.4 /0.55	44	3.5 /0.55
		990	45	3.7 /0.60	44	3.2 /0.50	44	3.3 /0.55	44	3.4 /0.55
		775	42	3.3 /0.55	42	3.4 /0.55	42	3.5 /0.55	42	3.6 /0.60
		800	43	3.8 /0.60	42	3.2 /0.50	42	3.3 /0.55	42	3.4 /0.55
		825	43	3.6 /0.55	43	3.7 /0.60	43	3.8 /0.60	42	3.2 /0.50
		850	44	3.8 /0.60	43	3.5 /0.55	43	3.6 /0.55	43	3.7 /0.60
		875	44	3.6 /0.60	44	3.7 /0.60	43	3.4 /0.55	43	3.5 /0.55
U.S.A. Only	4001 (1220) to 5000 (1524)	900	44	3.4 /0.55	44	3.5 /0.55	44	3.7 /0.60	44	3.8 /0.60
		925	44	3.2 /0.50	44	3.4 /0.55	44	3.5 /0.55	44	3.6 /0.55
		950	45	3.7 /0.60	44	3.2 /0.50	44	3.3 /0.55	44	3.4 /0.55
		750	42	3.3 /0.50	42	3.4 /0.55	42	3.5 /0.55	42	3.6 /0.55
		775	43	3.7 /0.60	43	3.8 /0.60	42	3.3 /0.50	42	3.4 /0.55
		800	43	3.5 /0.55	43	3.6 /0.60	43	3.7 /0.60	43	3.8 /0.60
		825	44	3.8 /0.60	43	3.4 /0.55	43	3.5 /0.55	43	3.6 /0.60
U.S.A. Only	5001 (1525) to 6000 (1829)	850	44	3.5 /0.55	44	3.7 /0.60	44	3.8 /0.60	43	3.4 /0.55
		875	44	3.3 /0.50	44	3.4 /0.55	44	3.6 /0.55	44	3.7 /0.60
		900	45	3.7 /0.60	44	3.2 /0.50	44	3.3 /0.55	44	3.4 /0.55
		725	42	3.2 /0.50	42	3.3 /0.55	42	3.4 /0.55	42	3.5 /0.55
		750	43	3.7 /0.60	43	3.8 /0.60	42	3.2 /0.50	42	3.3 /0.55
		775	43	3.4 /0.55	43	3.5 /0.55	43	3.7 /0.60	43	3.8 /0.60
		800	44	3.7 /0.60	44	3.8 /0.60	43	3.4 /0.55	43	3.5 /0.55
U.S.A. Only	6001 (1830) to 7000 (2133)	825	44	3.5 /0.55	44	3.6 /0.55	44	3.7 /0.60	44	3.8 /0.60
		850	44	3.3 /0.50	44	3.4 /0.55	44	3.5 /0.55	44	3.6 /0.60
		875	45	3.7 /0.60	44	3.2 /0.50	44	3.3 /0.55	44	3.4 /0.55
		900	46	3.7 /0.60	46	3.8 /0.60	45	3.8 /0.60	44	3.2 /0.50
		675	42	3.4 /0.55	42	3.5 /0.55	42	3.6 /0.60	42	3.8 /0.60
		700	42	3.2 /0.50	42	3.3 /0.50	42	3.4 /0.55	42	3.5 /0.55
		725	43	3.6 /0.60	43	3.7 /0.60	43	3.8 /0.60	42	3.3 /0.50
U.S.A. Only	7000 (2133)	750	43	3.4 /0.55	43	3.5 /0.55	43	3.6 /0.55	43	3.7 /0.60
		775	44	3.6 /0.60	44	3.7 /0.60	43	3.4 /0.55	43	3.5 /0.55
		800	44	3.4 /0.55	44	3.5 /0.55	44	3.6 /0.60	44	3.7 /0.60
		825	44	3.2 /0.50	44	3.3 /0.55	44	3.4 /0.55	44	3.5 /0.55
		850	46	3.8 /0.60	45	3.8 /0.60	44	3.2 /0.50	44	3.3 /0.55
		875	46	3.8 /0.60	45	3.8 /0.60	44	3.2 /0.50	44	3.3 /0.55

A11251A

**Table 3 (Cont.) Orifice Size and Manifold Pressure (in. w.c.) for Gas Input Rate**

**TO BE USED WITH MODULATING FURNACES EXCEPT THE EXCEPT 59MN7A060V21-20 and 987MA60060V21**

**MODULATING FURNACE**  
 (TABULATED DATA BASED ON 20,000 BTUH MAX-HEAT / 8,000 BTUH MIN-HEAT PER BURNER,  
 DERATED 2%/1000 FT (305M) ABOVE SEA LEVEL)

ALTITUDE RANGE ft (m)	AVG. GAS HEAT VALUE AT ALTITUDE (Btu/cu ft)	SPECIFIC GRAVITY OF NATURAL GAS							
		0.58		0.60		0.62		0.64	
		Orifice No.	Mnflld Press Max/Min	Orifice No.	Mnflld Press Max/Min	Orifice No.	Mnflld Press Max/Min	Orifice No.	Mnflld Press Max/Min
U.S.A. Only 7001 (2134) to 8000 (2438)	650	42	3.4 /0.55	42	3.5 /0.55	42	3.6 /0.60	42	3.7 /0.60
	675	43	3.8 /0.60	42	3.2 /0.50	42	3.3 /0.55	42	3.4 /0.55
	700	43	3.5 /0.55	43	3.7 /0.60	43	3.8 /0.60	42	3.2 /0.50
	725	<b>44</b>	<b>3.8 /0.60</b>	43	3.4 /0.55	43	3.5 /0.55	43	3.6 /0.60
	750	44	3.5 /0.55	<b>44</b>	<b>3.7 /0.60</b>	<b>44</b>	<b>3.8 /0.60</b>	43	3.4 /0.55
	775	44	3.3 /0.55	44	3.4 /0.55	44	3.5 /0.55	<b>44</b>	<b>3.7 /0.60</b>
	800	45	3.8 /0.60	<b>44</b>	<b>3.2 /0.50</b>	<b>44</b>	<b>3.3 /0.55</b>	<b>44</b>	<b>3.4 /0.55</b>
	825	46	3.7 /0.60	46	3.8 /0.60	45	3.8 /0.60	<b>44</b>	<b>3.2 /0.50</b>
U.S.A. Only 8001 (2439) to 9000 (2743)	625	42	3.4 /0.55	42	3.5 /0.55	42	3.6 /0.55	42	3.7 /0.60
	650	43	3.8 /0.60	42	3.2 /0.50	42	3.3 /0.55	42	3.4 /0.55
	675	43	3.5 /0.55	43	3.6 /0.60	43	3.7 /0.60	42	3.2 /0.50
	700	<b>44</b>	<b>3.7 /0.60</b>	43	3.4 /0.55	43	3.5 /0.55	43	3.6 /0.55
	725	44	3.5 /0.55	<b>44</b>	<b>3.6 /0.60</b>	<b>44</b>	<b>3.7 /0.60</b>	<b>44</b>	<b>3.8 /0.60</b>
	750	44	3.3 /0.50	44	3.4 /0.55	44	3.5 /0.55	44	3.6 /0.55
	775	45	3.7 /0.60	<b>44</b>	<b>3.2 /0.50</b>	<b>44</b>	<b>3.3 /0.50</b>	<b>44</b>	<b>3.4 /0.55</b>
U.S.A. Only 9001 (2744) to 10000 (3048)	600	42	3.3 /0.55	42	3.4 /0.55	42	3.6 /0.55	42	3.7 /0.60
	625	43	3.7 /0.60	42	3.2 /0.50	42	3.3 /0.55	42	3.4 /0.55
	650	43	3.5 /0.55	43	3.6 /0.55	43	3.7 /0.60	43	3.8 /0.60
	675	<b>44</b>	<b>3.7 /0.60</b>	<b>44</b>	<b>3.8 /0.60</b>	43	3.4 /0.55	43	3.5 /0.55
	700	44	3.4 /0.55	44	3.5 /0.55	<b>44</b>	<b>3.7 /0.60</b>	<b>44</b>	<b>3.8 /0.60</b>
	725	44	3.2 /0.50	44	3.3 /0.55	44	3.4 /0.55	44	3.5 /0.55

\* Orifice numbers shown in **BOLD** are factory-installed.

\*Orifice numbers shown in **BOLD** are factory installed.

**Table 4**

**Orifice Size and Manifold Pressure (in. w.c.) for Gas Input Rate**

**TO BE USED WITH MODULATING FURNACES 59MN7A060V21-20 and 987MA60060V21 ONLY**

(TABULATED DATA BASED ON 20,200 BTUH MAX-HEAT / 8,000 BTUH MIN-HEAT PER BURNER, DERATED 2%/1000 FT (305M) ABOVE SEA LEVEL)

ALTITUDE RANGE ft (m)		AVG. GAS HEAT VALUE AT ALTITUDE (Btu/cu ft)	SPECIFIC GRAVITY OF NATURAL GAS							
			0.58		0.60		0.62		0.64	
			Orifice No.	Mnfl'd Press Max/Min	Orifice No.	Mnfl'd Press Max/Min	Orifice No.	Mnfl'd Press Max/Min	Orifice No.	Mnfl'd Press Max/Min
U.S.A. and Canada	0 (0) to 2000 (610)	900	42	3.2 /0.50	42	3.3 /0.50	42	3.4 /0.55	42	3.5 /0.55
		925	43	3.7 /0.55	43	3.8 /0.60	42	3.2 /0.50	42	3.3 /0.50
		950	43	3.5 /0.55	43	3.6 /0.55	43	3.7 /0.60	43	3.8 /0.60
		975	44	3.8 /0.60	43	3.4 /0.55	43	3.5 /0.55	43	3.6 /0.55
		1000	44	3.6 /0.55	44	3.7 /0.60	44	3.8 /0.60	43	3.5 /0.55
		1025	44	3.4 /0.55	44	3.5 /0.55	44	3.6 /0.55	44	3.8 /0.60
		1050	44	3.3 /0.50	44	3.4 /0.55	44	3.5 /0.55	44	3.6 /0.55
U.S.A. and Canada	2001 (611) to 3000 (914)	1075	45	3.8 /0.60	44	3.2 /0.50	44	3.3 /0.50	44	3.4 /0.55
		1100	46	3.8 /0.60	45	3.7 /0.60	44	3.2 /0.50	44	3.3 /0.50
		800	42	3.4 /0.55	42	3.5 /0.55	42	3.7 /0.55	42	3.8 /0.60
U.S.A. and Canada	Canada 2001 (611) to 4500 (1372)	825	42	3.2 /0.50	42	3.3 /0.50	42	3.4 /0.55	42	3.6 /0.55
		850	43	3.7 /0.60	43	3.8 /0.60	42	3.2 /0.50	42	3.3 /0.55
		875	43	3.5 /0.55	43	3.6 /0.55	43	3.7 /0.60	43	3.8 /0.60
		900	44	3.8 /0.60	43	3.4 /0.55	43	3.5 /0.55	43	3.6 /0.55
		925	44	3.6 /0.55	44	3.7 /0.60	44	3.8 /0.60	43	3.4 /0.55
		950	44	3.4 /0.55	44	3.5 /0.55	44	3.6 /0.55	44	3.7 /0.60
		975	44	3.2 /0.50	44	3.3 /0.50	44	3.4 /0.55	44	3.6 /0.55
U.S.A. Only	3001 (915) to 4000 (1219)	1000	45	3.7 /0.60	44	3.2 /0.50	44	3.3 /0.50	44	3.4 /0.55
		775	42	3.4 /0.55	42	3.5 /0.55	42	3.6 /0.55	42	3.7 /0.60
		800	42	3.2 /0.50	42	3.3 /0.50	42	3.4 /0.55	42	3.5 /0.55
		825	43	3.6 /0.55	43	3.7 /0.60	42	3.2 /0.50	42	3.3 /0.50
		850	43	3.4 /0.55	43	3.5 /0.55	43	3.6 /0.55	43	3.8 /0.60
		875	44	3.7 /0.60	44	3.8 /0.60	43	3.4 /0.55	43	3.6 /0.55
U.S.A. Only	4001 (1220) to 5000 (1524)	900	44	3.5 /0.55	44	3.6 /0.55	44	3.7 /0.60	43	3.4 /0.55
		925	44	3.3 /0.50	44	3.4 /0.55	44	3.5 /0.55	44	3.6 /0.55
		950	45	3.8 /0.60	44	3.2 /0.50	44	3.4 /0.55	44	3.5 /0.55
		750	42	3.3 /0.50	42	3.4 /0.55	42	3.6 /0.55	42	3.7 /0.55
		775	43	3.8 /0.60	42	3.2 /0.50	42	3.3 /0.50	42	3.4 /0.55
		800	43	3.6 /0.55	43	3.7 /0.60	43	3.8 /0.60	42	3.2 /0.50
U.S.A. Only	5001 (1525) to 6000 (1829)	825	44	3.8 /0.60	43	3.5 /0.55	43	3.6 /0.55	43	3.7 /0.60
		850	44	3.6 /0.55	44	3.7 /0.60	43	3.4 /0.55	43	3.5 /0.55
		875	44	3.4 /0.55	44	3.5 /0.55	44	3.6 /0.55	44	3.8 /0.60
		900	44	3.2 /0.50	44	3.3 /0.50	44	3.4 /0.55	44	3.6 /0.55
		925	45	3.7 /0.60	44	3.2 /0.50	44	3.3 /0.50	44	3.4 /0.55
		950	46	3.8 /0.60	45	3.7 /0.60	44	3.2 /0.50	44	3.3 /0.50
U.S.A. Only	6001 (1830) to 7000 (2133)	725	42	3.5 /0.55	42	3.6 /0.55	42	3.7 /0.60	42	3.8 /0.60
		750	42	3.2 /0.50	42	3.3 /0.50	42	3.5 /0.55	42	3.6 /0.55
		775	43	3.7 /0.60	43	3.8 /0.60	42	3.2 /0.50	42	3.3 /0.50
		800	43	3.4 /0.55	43	3.5 /0.55	43	3.7 /0.55	43	3.8 /0.60
		825	44	3.7 /0.60	44	3.8 /0.60	43	3.4 /0.55	43	3.5 /0.55
		850	44	3.5 /0.55	44	3.6 /0.55	44	3.7 /0.60	44	3.8 /0.60
		875	44	3.2 /0.50	44	3.4 /0.55	44	3.5 /0.55	44	3.6 /0.55
900	45	3.7 /0.60	44	3.2 /0.50	44	3.3 /0.50	44	3.4 /0.55		

L11F100A

**Table 4 (Cont.) Orifice Size and Manifold Pressure (in. w.c.) for Gas Input Rate**

**TO BE USED WITH MODULATING FURNACES 59MN7A060V21-20 and 987MA60060V21 ONLY**

(TABULATED DATA BASED ON 20,200 BTUH MAX-HEAT / 8,000 BTUH MIN-HEAT PER BURNER,  
DERATED 2%/1000 FT (305M) ABOVE SEA LEVEL)

ALTITUDE RANGE ft (m)		AVG. GAS HEAT VALUE AT ALTITUDE (Btu/cu ft)	SPECIFIC GRAVITY OF NATURAL GAS							
			0.58		0.60		0.62		0.64	
			Orifice No.	Mnflld Press Max/Min	Orifice No.	Mnflld Press Max/Min	Orifice No.	Mnflld Press Max/Min	Orifice No.	Mnflld Press Max/Min
U.S.A. Only	7001 (2134) to 8000 (2438)	650	42	3.4 /0.55	42	3.6 /0.55	42	3.7 /0.60	42	3.8 /0.60
		675	42	3.2 /0.50	42	3.3 /0.50	42	3.4 /0.55	42	3.5 /0.55
		700	43	3.6 /0.55	43	3.7 /0.60	42	3.2 /0.50	42	3.3 /0.50
		725	43	3.4 /0.55	43	3.5 /0.55	43	3.6 /0.55	43	3.7 /0.60
		750	<b>44</b>	<b>3.6 /0.55</b>	<b>44</b>	<b>3.7 /0.60</b>	43	3.4 /0.55	43	3.5 /0.55
		775	<b>44</b>	<b>3.4 /0.55</b>	<b>44</b>	<b>3.5 /0.55</b>	<b>44</b>	<b>3.6 /0.55</b>	<b>44</b>	<b>3.7 /0.60</b>
		800	<b>44</b>	<b>3.2 /0.50</b>	<b>44</b>	<b>3.3 /0.50</b>	<b>44</b>	<b>3.4 /0.55</b>	<b>44</b>	<b>3.5 /0.55</b>
	825	46	3.8 /0.60	45	3.7 /0.60	<b>44</b>	<b>3.2 /0.50</b>	<b>44</b>	<b>3.3 /0.50</b>	
U.S.A. Only	8001 (2439) to 9000 (2743)	625	42	3.4 /0.55	42	3.5 /0.55	42	3.7 /0.55	42	3.8 /0.60
		650	42	3.2 /0.50	42	3.3 /0.50	42	3.4 /0.55	42	3.5 /0.55
		675	43	3.6 /0.55	43	3.7 /0.60	43	3.8 /0.60	42	3.2 /0.50
		700	<b>44</b>	<b>3.8 /0.60</b>	43	3.4 /0.55	43	3.6 /0.55	43	3.7 /0.55
		725	<b>44</b>	<b>3.6 /0.55</b>	<b>44</b>	<b>3.7 /0.60</b>	<b>44</b>	<b>3.8 /0.60</b>	43	3.4 /0.55
		750	<b>44</b>	<b>3.3 /0.50</b>	<b>44</b>	<b>3.4 /0.55</b>	<b>44</b>	<b>3.5 /0.55</b>	<b>44</b>	<b>3.7 /0.55</b>
	775	45	3.8 /0.60	<b>44</b>	<b>3.2 /0.50</b>	<b>44</b>	<b>3.3 /0.50</b>	<b>44</b>	<b>3.4 /0.55</b>	
U.S.A. Only	9001 (2744) to 10000 (3048)	600	42	3.4 /0.55	42	3.5 /0.55	42	3.6 /0.55	42	3.8 /0.60
		625	43	3.8 /0.60	42	3.2 /0.50	42	3.3 /0.55	42	3.5 /0.55
		650	43	3.5 /0.55	43	3.6 /0.55	43	3.8 /0.60	42	3.2 /0.50
		675	<b>44</b>	<b>3.8 /0.60</b>	43	3.4 /0.55	43	3.5 /0.55	43	3.6 /0.55
		700	<b>44</b>	<b>3.5 /0.55</b>	<b>44</b>	<b>3.6 /0.55</b>	<b>44</b>	<b>3.7 /0.60</b>	<b>44</b>	<b>3.8 /0.60</b>
	725	<b>44</b>	<b>3.3 /0.50</b>	<b>44</b>	<b>3.4 /0.55</b>	<b>44</b>	<b>3.5 /0.55</b>	<b>44</b>	<b>3.6 /0.55</b>	

\* Orifice numbers shown in **BOLD** are factory-installed.



Table 5

## Orifice Size and Manifold Pressure (in.w.c.) for Gas Input Rate for Two-Stage Gas Valves

ALTITUDE RANGE ft (m)		AVG. GAS HEAT VALUE AT ALTITUDE (Btu/cu ft)	SPECIFIC GRAVITY OF NATURAL GAS							
			0.58		0.60		0.62		0.64	
			Orifice No.	Mnfl'd Press High/Low	Orifice No.	Mnfl'd Press High/Low	Orifice No.	Mnfl'd Press High/Low	Orifice No.	Mnfl'd Press High/Low
U.S.A. and Canada	0 (0) to 2000 (610)	900	43	3.8 / 1.6	42	3.2 / 1.4	42	3.3 / 1.4	42	3.4 / 1.4
		925	43	3.6 / 1.5	43	3.7 / 1.6	43	3.8 / 1.6	42	3.2 / 1.4
		950	43	3.4 / 1.4	43	3.5 / 1.5	43	3.6 / 1.5	43	3.7 / 1.6
		975	44	3.7 / 1.6	44	3.8 / 1.6	43	3.4 / 1.5	43	3.6 / 1.5
		1000	44	3.5 / 1.5	44	3.6 / 1.5	44	3.8 / 1.6	43	3.4 / 1.4
		1025	44	3.3 / 1.4	44	3.5 / 1.5	44	3.6 / 1.5	44	3.7 / 1.6
		1050	44	3.2 / 1.3	44	3.3 / 1.4	44	3.4 / 1.4	44	3.5 / 1.5
		1075	45	3.7 / 1.6	45	3.8 / 1.6	44	3.3 / 1.4	44	3.4 / 1.4
	1100	46	3.7 / 1.6	46	3.8 / 1.6	45	3.8 / 1.6	44	3.2 / 1.4	
U.S.A. and Canada	U.S.A. 2001 (611) to 3000 (914)  Canada 2001 (611) to 4500 (1372)	800	42	3.4 / 1.4	42	3.5 / 1.5	42	3.6 / 1.5	42	3.7 / 1.6
		825	43	3.8 / 1.6	42	3.3 / 1.4	42	3.4 / 1.4	42	3.5 / 1.5
		850	43	3.6 / 1.5	43	3.7 / 1.6	42	3.2 / 1.3	42	3.3 / 1.4
		875	43	3.4 / 1.4	43	3.5 / 1.5	43	3.7 / 1.5	43	3.8 / 1.6
		900	44	3.7 / 1.6	44	3.8 / 1.6	43	3.5 / 1.5	43	3.6 / 1.5
		925	44	3.5 / 1.5	44	3.6 / 1.5	44	3.8 / 1.6	43	3.4 / 1.4
		950	44	3.3 / 1.4	44	3.4 / 1.5	44	3.6 / 1.5	44	3.7 / 1.6
		975	44	3.2 / 1.3	44	3.3 / 1.4	44	3.4 / 1.4	44	3.5 / 1.5
	1000	46	3.8 / 1.6	45	3.8 / 1.6	44	3.2 / 1.4	44	3.3 / 1.4	
U.S.A. Only	3001 (915) to 4000 (1219)	775	42	3.3 / 1.4	42	3.4 / 1.4	42	3.5 / 1.5	42	3.6 / 1.5
		800	43	3.8 / 1.6	42	3.2 / 1.4	42	3.3 / 1.4	42	3.4 / 1.4
		825	43	3.6 / 1.5	43	3.7 / 1.6	43	3.8 / 1.6	42	3.2 / 1.4
		850	44	3.8 / 1.6	43	3.5 / 1.5	43	3.6 / 1.5	43	3.7 / 1.6
		875	44	3.6 / 1.5	44	3.7 / 1.6	43	3.4 / 1.4	43	3.5 / 1.5
		900	44	3.4 / 1.4	44	3.5 / 1.5	44	3.7 / 1.5	44	3.8 / 1.6
		925	44	3.2 / 1.4	44	3.4 / 1.4	44	3.5 / 1.5	44	3.6 / 1.5
	950	45	3.7 / 1.6	44	3.2 / 1.3	44	3.3 / 1.4	44	3.4 / 1.4	
U.S.A. Only	4001 (1220) to 5000 (1524)	750	42	3.3 / 1.4	42	3.4 / 1.4	42	3.5 / 1.5	42	3.6 / 1.5
		775	43	3.7 / 1.6	43	3.8 / 1.6	42	3.3 / 1.4	42	3.4 / 1.4
		800	43	3.5 / 1.5	43	3.6 / 1.5	43	3.7 / 1.6	43	3.8 / 1.6
		825	44	3.8 / 1.6	43	3.4 / 1.4	43	3.5 / 1.5	43	3.6 / 1.5
		850	44	3.5 / 1.5	44	3.7 / 1.5	44	3.8 / 1.6	43	3.4 / 1.4
		875	44	3.3 / 1.4	44	3.5 / 1.5	44	3.6 / 1.5	44	3.7 / 1.6
		900	44	3.2 / 1.3	44	3.3 / 1.4	44	3.4 / 1.4	44	3.5 / 1.5
	925	46	3.8 / 1.6	45	3.7 / 1.6	44	3.2 / 1.4	44	3.3 / 1.4	
U.S.A. Only	5001 (1525) to 6000 (1829)	725	42	3.2 / 1.4	42	3.3 / 1.4	42	3.4 / 1.5	42	3.5 / 1.5
		750	43	3.7 / 1.5	43	3.8 / 1.6	42	3.2 / 1.4	42	3.3 / 1.4
		775	43	3.4 / 1.4	43	3.5 / 1.5	43	3.7 / 1.5	43	3.8 / 1.6
		800	44	3.7 / 1.6	44	3.8 / 1.6	43	3.4 / 1.5	43	3.5 / 1.5
		825	44	3.5 / 1.5	44	3.6 / 1.5	44	3.7 / 1.6	44	3.8 / 1.6
		850	44	3.3 / 1.4	44	3.4 / 1.4	44	3.5 / 1.5	44	3.6 / 1.5
		875	45	3.7 / 1.6	44	3.2 / 1.3	44	3.3 / 1.4	44	3.4 / 1.4
	900	46	3.7 / 1.6	46	3.8 / 1.6	45	3.8 / 1.6	44	3.2 / 1.4	
U.S.A. Only	6001 (1830) to 7000 (2133)	675	42	3.4 / 1.4	42	3.5 / 1.5	42	3.6 / 1.5	42	3.8 / 1.6
		700	42	3.2 / 1.3	42	3.3 / 1.4	42	3.4 / 1.4	42	3.5 / 1.5
		725	43	3.6 / 1.5	43	3.7 / 1.6	43	3.8 / 1.6	42	3.3 / 1.4
		750	43	3.4 / 1.4	43	3.5 / 1.5	43	3.6 / 1.5	43	3.7 / 1.6
		775	44	3.6 / 1.5	44	3.7 / 1.6	43	3.4 / 1.4	43	3.5 / 1.5
		800	44	3.4 / 1.4	44	3.5 / 1.5	44	3.6 / 1.5	44	3.7 / 1.6
		825	44	3.2 / 1.3	44	3.3 / 1.4	44	3.4 / 1.4	44	3.5 / 1.5
	850	46	3.8 / 1.6	45	3.8 / 1.6	44	3.2 / 1.4	44	3.3 / 1.4	

A11252A



Table 5

**Orifice Size and Manifold Pressure (in.w.c.) for Gas Input Rate for Two-Stage Gas Valves (continued)**

**TWO-STAGE FURNACE**  
 (TABULATED DATA BASED ON 20,000 BTUH HIGH-HEAT / 13,000 BTUH LOW-HEAT PER BURNER,  
 DERATED 2%/1000 FT (305M) ABOVE SEA LEVEL)

ALTITUDE RANGE ft (m)		AVG. GAS HEAT VALUE AT ALTITUDE (Btu/cu ft)	SPECIFIC GRAVITY OF NATURAL GAS							
			0.58		0.60		0.62		0.64	
			Orifice No.	Mnfl'd Press High/Low	Orifice No.	Mnfl'd Press High/Low	Orifice No.	Mnfl'd Press High/Low	Orifice No.	Mnfl'd Press High/Low
U.S.A. Only	7001 (2134) to 8000 (2438)	650	42	3.4 / 1.4	42	3.5 / 1.5	42	3.6 / 1.5	42	3.7 / 1.6
		675	43	3.8 / 1.6	42	3.2 / 1.4	42	3.3 / 1.4	42	3.4 / 1.5
		700	43	3.5 / 1.5	43	3.7 / 1.5	43	3.8 / 1.6	42	3.2 / 1.4
		725	<b>44</b>	<b>3.8 / 1.6</b>	43	3.4 / 1.4	43	3.5 / 1.5	43	3.6 / 1.5
		750	<b>44</b>	<b>3.5 / 1.5</b>	<b>44</b>	<b>3.7 / 1.5</b>	<b>44</b>	<b>3.8 / 1.6</b>	43	3.4 / 1.4
		775	<b>44</b>	<b>3.3 / 1.4</b>	<b>44</b>	<b>3.4 / 1.4</b>	<b>44</b>	<b>3.5 / 1.5</b>	<b>44</b>	<b>3.7 / 1.5</b>
		800	45	3.8 / 1.6	<b>44</b>	<b>3.2 / 1.4</b>	<b>44</b>	<b>3.3 / 1.4</b>	<b>44</b>	<b>3.4 / 1.4</b>
		825	46	3.7 / 1.6	46	3.8 / 1.6	45	3.8 / 1.6	<b>44</b>	<b>3.2 / 1.4</b>
U.S.A. Only	8001 (2439) to 9000 (2743)	625	42	3.4 / 1.4	42	3.5 / 1.5	42	3.6 / 1.5	42	3.7 / 1.6
		650	43	3.8 / 1.6	42	3.2 / 1.4	42	3.3 / 1.4	42	3.4 / 1.4
		675	43	3.5 / 1.5	43	3.6 / 1.5	43	3.7 / 1.6	42	3.2 / 1.3
		700	<b>44</b>	<b>3.7 / 1.6</b>	43	3.4 / 1.4	43	3.5 / 1.5	43	3.6 / 1.5
		725	<b>44</b>	<b>3.5 / 1.5</b>	<b>44</b>	<b>3.6 / 1.5</b>	<b>44</b>	<b>3.7 / 1.6</b>	<b>44</b>	<b>3.8 / 1.6</b>
		750	<b>44</b>	<b>3.3 / 1.4</b>	<b>44</b>	<b>3.4 / 1.4</b>	<b>44</b>	<b>3.5 / 1.5</b>	<b>44</b>	<b>3.6 / 1.5</b>
		775	45	3.7 / 1.6	<b>44</b>	<b>3.2 / 1.3</b>	<b>44</b>	<b>3.3 / 1.4</b>	<b>44</b>	<b>3.4 / 1.4</b>
U.S.A. Only	9001 (2744) to 10000 (3048)	600	42	3.3 / 1.4	42	3.4 / 1.5	42	3.6 / 1.5	42	3.7 / 1.6
		625	43	3.7 / 1.6	42	3.2 / 1.3	42	3.3 / 1.4	42	3.4 / 1.4
		650	43	3.5 / 1.5	43	3.6 / 1.5	43	3.7 / 1.6	43	3.8 / 1.6
		675	<b>44</b>	<b>3.7 / 1.6</b>	<b>44</b>	<b>3.8 / 1.6</b>	43	3.4 / 1.4	43	3.5 / 1.5
		700	<b>44</b>	<b>3.4 / 1.4</b>	<b>44</b>	<b>3.5 / 1.5</b>	<b>44</b>	<b>3.7 / 1.5</b>	<b>44</b>	<b>3.8 / 1.6</b>
		725	<b>44</b>	<b>3.2 / 1.3</b>	<b>44</b>	<b>3.3 / 1.4</b>	<b>44</b>	<b>3.4 / 1.4</b>	<b>44</b>	<b>3.5 / 1.5</b>

\* Orifice numbers shown in **BOLD** are factory-installed.

A11252B

**REINSTALL BURNER ASSEMBLY**

To reinstall burner assembly:

1. Attach flame sensor to burner assembly.
2. Insert one-piece burner in slot on sides of burner box and slide burner back in place.
3. Reattach HSI wires to HSI.
4. Verify igniter to burner alignment. (See **Figure 6** and **Figure 7**)

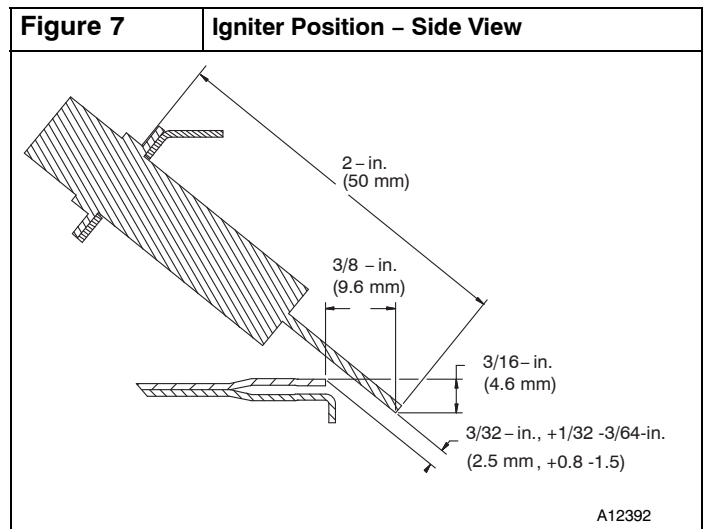
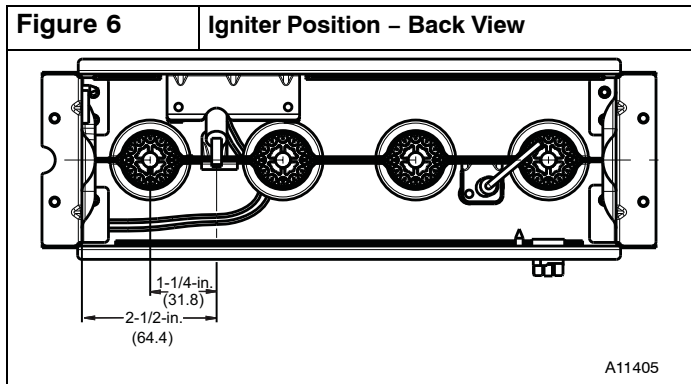

## CONVERT GAS VALVE



### CAUTION

#### UNIT DAMAGE HAZARD

Failure to follow this caution may result in unit damage.

The gas valve must be converted and pre-adjusted before operating on natural gas. If not converted and pre-adjusted, sooting and corrosion will occur leading to early heat exchanger failure.



### WARNING

#### FIRE, EXPLOSION, ELECTRICAL SHOCK HAZARD

Failure to follow this warning could result in personal injury, death or property damage.

Gas supply **MUST** be shut off before disconnecting electrical power and proceeding with conversion.



### WARNING

#### ELECTRICAL SHOCK, FIRE OR EXPLOSION HAZARD

Failure to follow this warning could result in personal injury, death or property damage.

Before installing, modifying, or servicing system, main electrical disconnect switch must be in the OFF position and install a lockout tag. There may be more than one disconnect switch. Lock out and tag switch with a suitable warning label. Verify proper operation after servicing.

### 59MN7A & 987MA – Modulating Gas Valve

Refer to **Figure 8** and **Figure 9**.

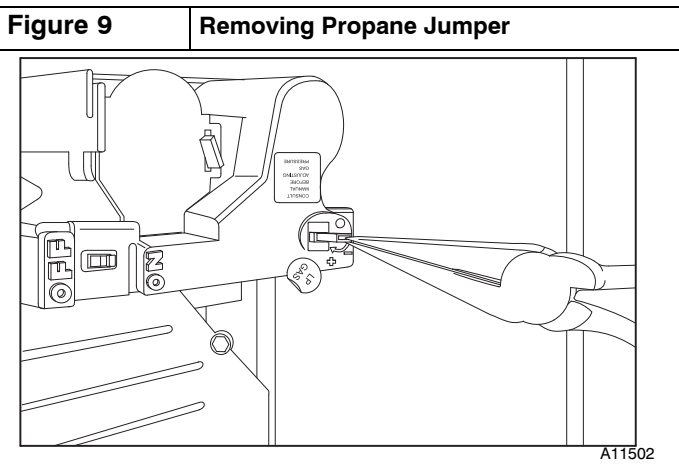
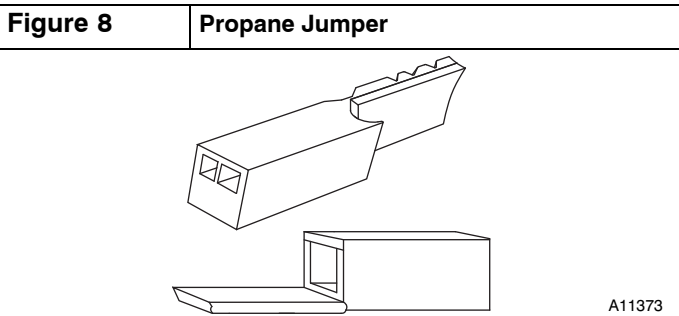

**NOTE:** The Propane jumper for the modulating gas valve is very small. Needle-nose pliers are required to remove the jumper from the gas valve.

1. Locate the round “LP” gas sticker on the top of the gas valve.
2. Remove “LP” gas sticker and discard.
3. Note the small square opening in the top of the gas valve.
4. Remove the small black plastic Propane jumper from the gas valve.
5. Cover the opening in the gas valve with the label marked “NAT” gas.

### 59TN6, 59TP6, 986T, 926T, PG96V\_T – Two Stage Gas Valve

1. Refer to **Figure 17**.
2. Be sure gas and electrical supplies to furnace are off.
3. Remove caps that conceal the adjustment screws for high-heat and low-heat gas valve regulators. (See **Figure 17**)
4. Remove the high-heat and low-heat regulator adjustment screws.
5. Remove the high-heat and low-heat Propane regulator springs (white).
6. Install the high-heat and low-heat natural gas regulator springs (silver).
7. Install the high-heat and low-heat regulator adjustment screws.
8. Turn high-heat stage adjusting screw clockwise (in) 12 full turns. This will increase the manifold pressure closer to the natural set point.
9. Turn low-heat stage adjusting screw clockwise (in) 9.5 full turns. This will increase the manifold pressure closer to the natural gas low-heat set point.
10. DO NOT install regulator seal caps at this time.

## REMOVE LOW GAS PRESSURE SWITCH

**NOTE:** There are two ways that the Low Gas Pressure Switch (LGPS) could have been installed during the original natural to Propane gas conversion.

### All 14 3/16-in Casings or Vent Passes Between Inducer Assembly and Burner Assembly

If the vent pipe passes between the inducer and burner assembly, or the furnace is a 14 3/16-in. wide casing. The switch may be installed as shown in **Figure 10**.

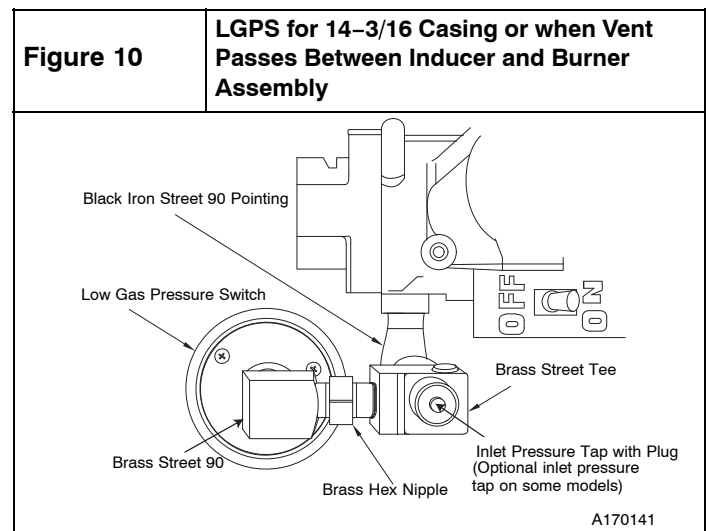

1. Remove low-gas pressure switch, brass street 90° elbow, brass Hex nipple, brass tee and black iron street 90°

elbow from the gas valve inlet pressure tap. (See **Figure 10**)

**NOTE:** DO NOT use Teflon tape.

2. Apply pipe dope sparingly to the 1/8-in. (3 mm) NPT pipe plug and install in the 1/8-in (3 mm) tapped inlet–pressure tap opening in the gas valve. DO NOT over–tighten. Check for gas leaks after gas supply has been turned on.

⚠ **WARNING**

**FIRE AND EXPLOSION HAZARD**

Failure to follow this warning could result in personal injury and/or death.

NEVER test for gas leaks with an open flame. Use a commercially available soap solution made specifically for the detection of leaks to check all connections. A fire or explosion may result causing property damage, personal injury or loss of life.

⚠ **AVERTISSEMENT**

**RISQUE D'EXPLOSION ET D'INCENDIE**

Le fait de ne pas suivre cet avertissement pourrait entraîner des dommages corporels et / ou la mort.

Ne jamais examiner pour les fuites de gaz avec une flamme vive. Utilisez plutôt un savon fait spécifiquement pour la détection des fuites de gaz pour vérifier tous les connexions. Un incendie ou une explosion peut entraîner des dommages matériels, des blessures ou la mort.

**Casings Wider Than 14 3/16-in./Vent Does Not Pass Between Inducer and Burner Assembly**

If the vent pipe does not pass between the inducer and burner assembly, or the furnace is wider than a 14 3/16-in. wide casing. The switch may be installed as shown in **Figure 11**.

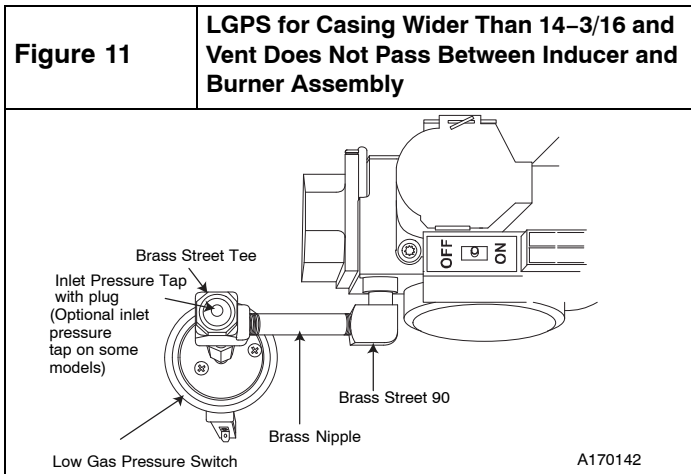

1. Remove low gas pressure switch, brass street 90° elbow, brass Hex nipple, brass Tee and brass nipple from the gas valve inlet pressure tap. (See **Figure 11**)

**NOTE:** DO NOT use Teflon tape.

2. Apply pipe dope sparingly to the 1/8-in. (3 mm) NPT pipe plug and install in the 1/8-in (3 mm) tapped inlet–pressure tap opening in the gas valve. DO NOT over–tighten. Check for gas leaks after gas supply has been turned on.

**INSTALL MANIFOLD**

1. Align the orifices in the manifold assembly with the support rings on the end of the burner.

2. Insert the orifices in the support rings of the burners. Manifold mounting tabs should fit flush against the burner box

**NOTE:** If manifold does not fit flush against the burner box, the burners are not fully seated forward. Remove the manifold and check burner positioning in the burner box assembly.

3. Attach the green/yellow wire and ground terminal to one of the manifold mounting screws.
4. Install the remaining manifold mounting screws.
5. Connect the wires to the flame sensor and hot surface igniter.
6. Connect the connector harness to gas valve.
7. Rewire unit low pressure switch (LPS) as follows:
  - a. Trace one of the orange wires previously disconnected from the LGPS back to the NO terminals of the LPS.
  - b. Trace the other orange wire previously disconnected from the LGPS back to its splice connection with the yellow wire of the furnace wire harness. Disconnect and discard this orange wire and the splice connection.
  - c. Connect the yellow wire of the furnace wire harness (see “b” above) to the NO terminal of the LPS.
  - d. Refer to the furnace wiring diagram to ensure proper location of wires.

**NOTE:** DO NOT use Teflon tape.

8. Insert the gas pipe through the grommet in the casing. Apply a thin layer of pipe dope to the threads of the pipe and thread the pipe into the gas valve.

**NOTE:** Use a back-up wrench on the gas valve to prevent the valve from rotating on the manifold or damaging the mounting to the burner box.

9. With a back-up wrench on the inlet boss of the gas valve, finish tightening the gas pipe to the gas valve.
10. Turn gas on at electric switch on gas valve.

**CHECK INLET GAS PRESSURE**

⚠ **CAUTION**

**UNIT DAMAGE HAZARD**

Failure to follow this caution may result in unit damage.

DO NOT operate furnace more than one minute to check inlet gas pressure, as conversion is not complete at this time.

**NOTE:** This kit is to be used only when inlet gas pressure is between 4.5-in. w.c. and 13.6-in. w.c.

1. On some models, remove 1/8-in. (3 mm) plug from the pressure tap on the inlet end of gas valve and insert pressure tap. Or, on some models, loosen set screw on inlet tower pressure tap no more than one full turn with the 3/32-in. hex wrench.
2. Verify manometer is connected to inlet pressure tap on gas valve.
3. Turn on furnace power supply.
4. Turn gas supply manual shutoff valve to ON position.
5. Turn furnace gas valve switch to ON position.

⚠ **WARNING**

**FIRE, EXPLOSION, ELECTRICAL SHOCK HAZARD**

Failure to follow this warning could result in personal injury, death or property damage.

Gas supply MUST be shut off before disconnecting electrical power and proceeding with conversion.



# WARNING

## ELECTRICAL SHOCK, FIRE OR EXPLOSION HAZARD

Failure to follow this warning could result in personal injury, death or property damage.

Before installing, modifying, or servicing system, main electrical disconnect switch must be in the OFF position and install a lockout tag. There may be more than one disconnect switch. Lock out and tag switch with a suitable warning label. Verify proper operation after servicing.

### 59MN7A & 987MA – Modulating Gas Valve

1. Turn Setup Switch SW1-2 on furnace control ON (see **Figure 12**)
2. Jumper R-W/W1 and R-W2 thermostat connections on control.
3. When main burners ignite, confirm inlet gas pressure is between 4.5-in. w.c. and 13.6-in. w.c.
4. Remove jumper across R-W/W1 and R-W2 thermostat connections to terminate call for heat.
5. Turn furnace gas valve switch to OFF position.
6. Turn gas supply manual shutoff valve to OFF position.
7. Turn off furnace power supply.
8. Remove manometer and on some models the pressure tap fitting.
9. On some models, apply pipe dope sparingly to the 1/8-in. (3 mm) NPT pipe plug and install in the 1/8-in. (3 mm) tapped inlet-pressure tap opening in the gas valve. Or, on some models, tighten set screw on inlet tower pressure tap with a 3/32-in. hex wrench. (See **Figure 14**)

### 59TN6, 59TP6, 986T, 926T, PG96V\_T – Two Stage Gas Valve

1. Turn Setup Switch SW1-2 on furnace control ON (See **Figure 13**)
2. Jumper R-W/W1 and R-W2 thermostat connections on control.
3. When main burners ignite, confirm inlet gas pressure is between 4.5-in. w.c. and 13.6-in. w.c.
4. Remove jumper across R-W/W1 and R-W2 thermostat connections to terminate call for heat.
5. Turn furnace gas valve switch to OFF position.
6. Turn gas supply manual shutoff valve to OFF position.
7. Turn off furnace power supply.
8. Remove manometer and on some models remove pressure tap fitting.
9. On some models, apply pipe dope sparingly to the end of inlet gas pipe plug and install into in the 1/8-in. (3 mm) tapped inlet-pressure tap opening in the gas valve. Or, on some models, tighten set screw on inlet tower pressure tap with a 3/32-in. hex wrench. (See **Figure 17**)

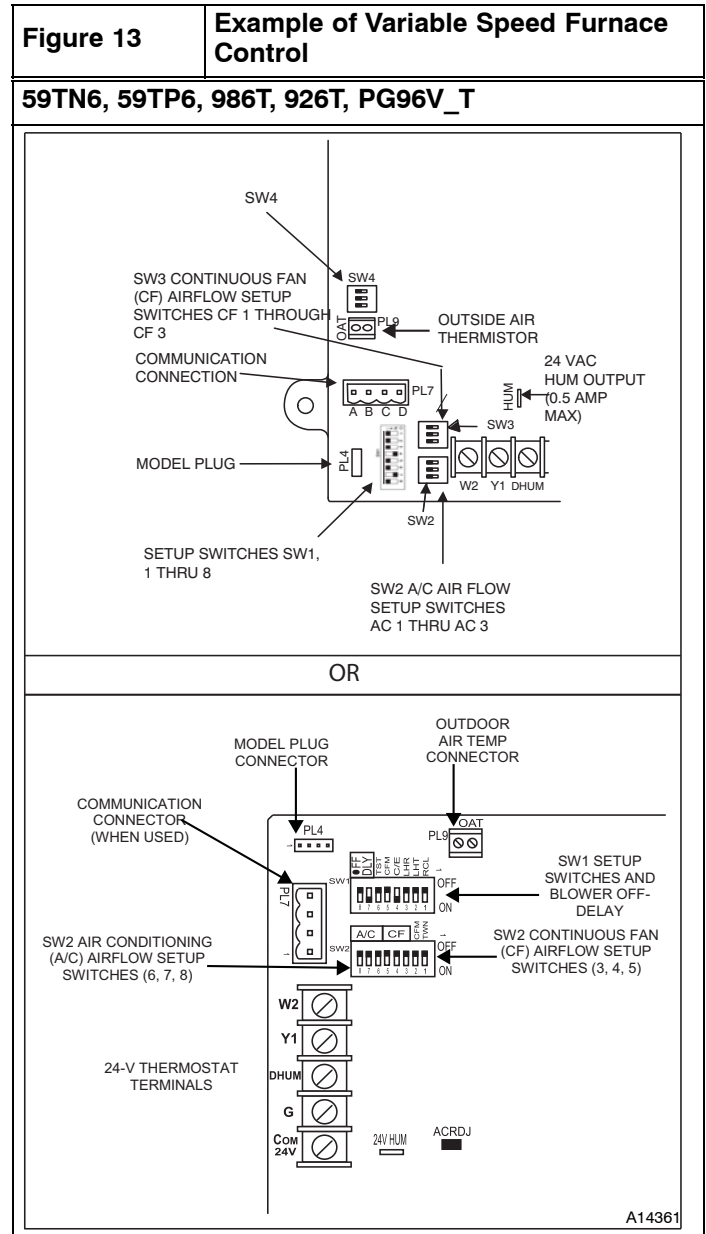
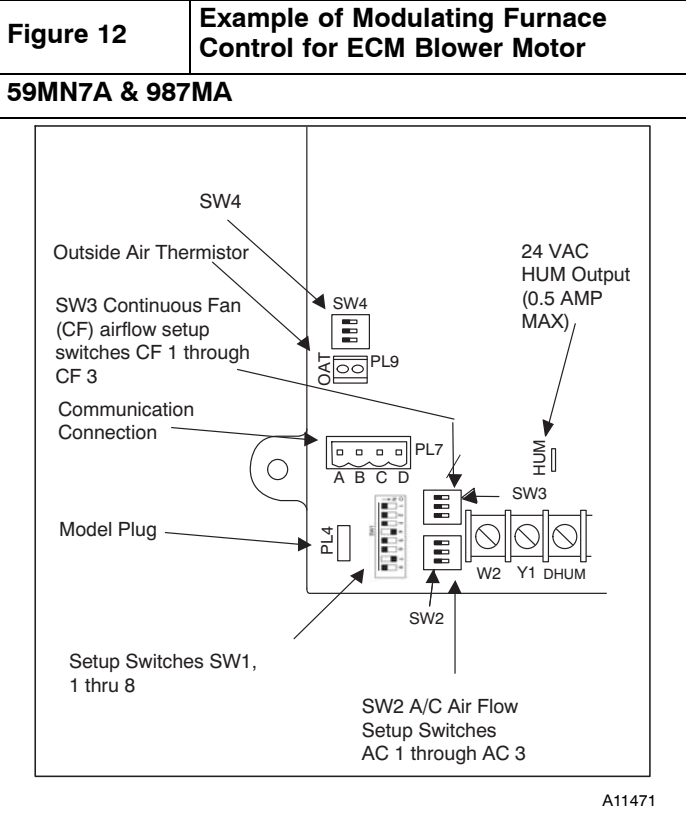

# CHECK FURNACE AND MAKE ADJUSTMENTS

**⚠ WARNING**

**FIRE AND EXPLOSION HAZARD**  
 Failure to follow this warning could result in personal injury and/or death.  
 NEVER test for gas leaks with an open flame. Use a commercially available soap solution made specifically for the detection of leaks to check all connections. A fire or explosion may result causing property damage, personal injury or loss of life.

**⚠ AVERTISSEMENT**

**RISQUE D'EXPLOSION ET D'INCENDIE**  
 Le fait de ne pas suivre cet avertissement pourrait entraîner des dommages corporels et / ou la mort.  
 Ne jamais examiner pour les fuites de gaz avec une flamme vive. Utilisez plutôt un savon fait spécifiquement pour la détection des fuites de gaz pour vérifier tous les connexions. Un incendie ou une explosion peut entraîner des dommages matériels, des blessures ou la mort.

1. Be sure main gas and electric supplies to furnace are off.
2. On some models, remove 1/8-in. (3 mm) pipe plug from manifold pressure tap on outlet end of gas valve and insert pressure tap. Or, on some models, loosen set screw on manifold tower pressure tap no more than one full turn with a 3/32-in. hex wrench.
3. Attach manometer to manifold pressure tap on gas valve. (See **Figure 14** or **Figure 17**)
4. Turn gas supply manual shutoff valve to ON position.
5. Turn furnace gas valve switch to ON position.
6. Check all threaded pipe connections for gas leaks.
7. Turn on furnace power supply.

## GAS INPUT RATE INFORMATION

See furnace rating plate on blower door for input rate. The input rate for natural gas is determined by manifold pressure and orifice size.

**NOTE:** The Modulating gas valve must be set for Maximum Heat first and then set for Minimum Heat on Modulating furnaces.

Determine natural gas orifice size and manifold pressures for correct input at installed altitude by using **Table 3** or **Table 5**.

1. Obtain yearly heat-value average (at installed altitude) for local gas supply.
2. Obtain yearly specific-gravity average for local gas supply.
3. Find installation altitude in **Table 3** or **Table 5**.

**NOTE:** For Canada altitudes of 2000 to 4500 ft., use U.S.A. Altitudes of 2001 to 3000 ft. In **Table 3** or **Table 5**.

4. Find closest natural gas heat value and specific gravity in **Table 3** or **Table 5**.
5. Follow heat-value line and specific-gravity line to point of intersection to find orifice size and maximum and minimum manifold pressure settings.

Furnace gas input rate on rating plate is for installations at altitudes up to 2000 ft. (610 M).

**In the U.S.A.,** the input rating for altitudes above 2000 ft. (610M) must be reduced by 2 percent for each 1000 ft. (305 M) above sea level.

**In Canada,** the input rating must be derated by 5 percent for altitudes of 2000 ft. (610 M) to 4500 ft. (1372 M) above sea level.

The Conversion Kit Rating Plate accounts for high altitude derate.

## SET GAS INPUT RATE

### 59MN7A & 987MA – Modulating Gas Valve

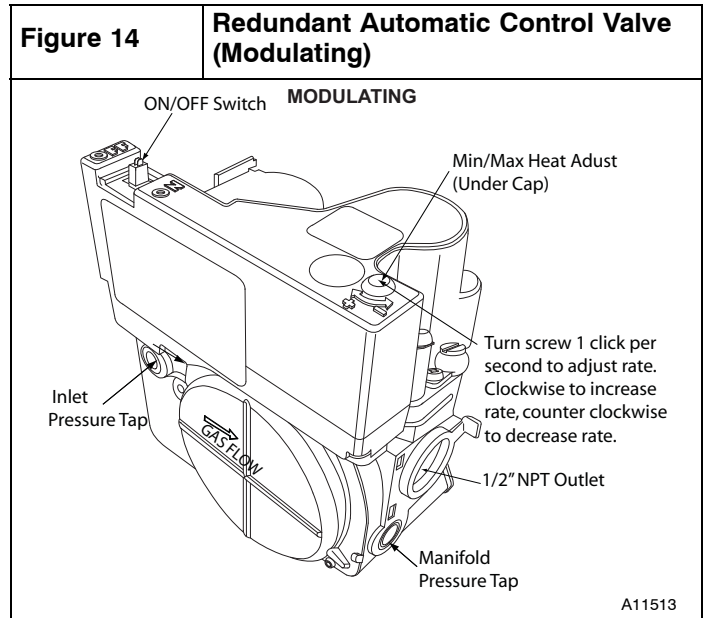

**Figure 14 (cont.) – Automatic Control Valve (Modulating) with Tower Pressure Ports**

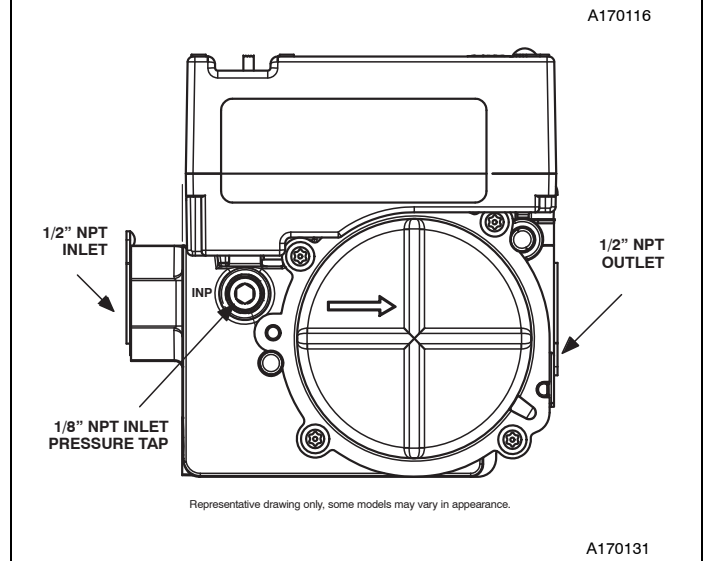
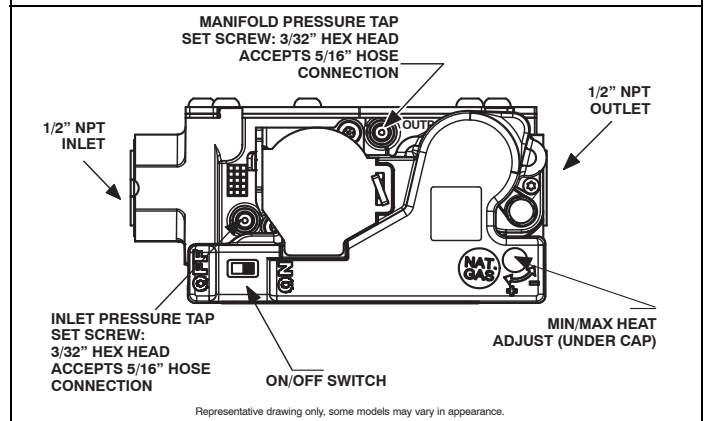



# CAUTION

## UNIT DAMAGE HAZARD

Failure to follow this caution may result in gas valve damage.

Do not force the rotary adjustment switch on the modulating gas valve. Do not turn the rotary adjustment switch faster than one click per second when adjusting manifold pressure. Gas valve will be damaged if excessive force is used on the rotary switch.

For proper operation and long term reliability, the manifold pressure must be adjusted as specified on the conversion kit rating plate.

The modulating furnace manifold pressure is set at two points. The first point is Maximum Heat. The second point is Minimum Heat. DO NOT adjust Intermediate Heat manifold pressure. Intermediate Heat manifold pressure can be checked as part of the temperature rise, but is not adjustable. Always adjust Maximum Heat first, then Minimum Heat.

**NOTE:** Use care when performing adjustments. Gas valve adjustment is performed by turning a rotary adjustment switch inside the gas valve with a small straight blade screwdriver. Excessive force can break or bend the rotary adjustment switch making it non-adjustable.

### To adjust manifold pressure to obtain input rate for Maximum Heat:

1. Turn Setup switch SW 1-2 to ON.
2. Verify Set-up switch SW 4-2 is turned OFF.
3. Jumper the R to W/W1 and W2 thermostat connections at the furnace control board.
4. After the main burners ignite and the blower starts, confirm Maximum Heat manifold pressure is correct, based on the manifold pressure table. (See **Figure 3**)
5. To adjust the Maximum Heat manifold pressure, slowly turn the rotary adjustment switch counterclockwise to decrease manifold pressure or clockwise to increase manifold pressure.
6. Turn rotary adjustment switch no more than one click per second until you obtain the required manifold pressure.

Main burner flame should be clear blue, almost transparent.

### To adjust manifold pressure to obtain input rate for Minimum Heat:

1. Remove the jumper from W2 at the thermostat connections at the furnace control board control.
2. Wait until the burners and the blower transitions to Minimum Heat.
3. Verify the Minimum Heat manifold pressure is correct, based on the manifold pressure table on Conversion Kit Rating Plate.
4. To adjust the Minimum Heat manifold pressure, Slowly turn the rotary adjustment switch counterclockwise to decrease manifold pressure or clockwise to increase manifold pressure.
5. Turn rotary adjustment switch no more than one click per second until you obtain the required manifold pressure. This adjustment will not affect the previous Maximum Heat adjustment.

After adjusting the manifold pressure, allow the furnace to operate an additional five minutes before checking Minimum Heat Temperature rise.

Furnace must operate within ranges of temperature rise specified on the furnace rating plate. Determine air temperature rise as follows:

1. Place thermometers in return and supply ducts as near furnace as possible. Be sure thermometers DO NOT see

heat exchanger so that radiant heat does not affect readings. This practice is particularly important with straight-run ducts.

2. When thermometer readings stabilize, subtract return-air temperature from supply-air temperature to determine air temperature rise.
3. Allow the furnace to run for at least ten minutes before checking Temperature Rise.

If the temperature rise is too high or too low in Minimum Heat:

1. Remove jumpers from R and W/W1.
2. Wait until the blower off delay is completed.
3. Turn 115 VAC power off.
4. Check the position of Heat Rise Adjustment Switch SW1-3. When set to ON, airflow is raised 18% higher for Minimum Heat and Intermediate Heat. Factory default position is OFF.
5. Turn 115 VAC power on.
6. Jumper R to W/W1 and W2.
7. After burners ignite and blower starts allow the furnace to run for at least 10 minutes before checking Temperature Rise.

### Maximum Heat Temperature Rise

If the temperature rise is too high or too low in Maximum Heat:

1. Remove jumpers from R, W1 and W2.
2. Wait until the blower off delay is completed.
3. Turn 115 VAC power off.
4. Check the position of the Efficiency/Comfort Adjustment switch SW1-4. When set to OFF (Efficiency Mode), airflow is 10% higher for Minimum, 7.5% for Intermediate Heat, and 17.5% for Maximum Heat. Factory default position is ON (Comfort Mode).
5. Turn 115 VAC power on.
6. Re-check Minimum Heat Temperature Rise.
7. Remove jumpers across thermostat connections to terminate the call for heat. Wait until the blower off delay is completed.
8. Turn gas supply manual shutoff valve to OFF position.
9. Turn off furnace power supply.
10. Remove manometer and on some models, the pressure tap fitting.
11. On some models, apply pipe dope sparingly to end of 1/8-in. (3 mm) pipe plug and install in the manifold pressure tap opening. Or, on some models, tighten set screw on manifold tower pressure tap with a 3/32-in. hex wrench. (See **Figure 14**)
12. Re-install plastic cap over rotary adjustment switch on the top of the gas valve.
13. Turn on furnace power supply.
14. Set room thermostat to call for heat.
15. Check pressure tap plug for gas leaks when main burners ignite.
16. Check for correct burner flame.
17. After making the required manifold pressure adjustments, check and adjust the furnace temperature rise per the furnace installation instructions.

## LABEL APPLICATION

1. Fill in Conversion Responsibility Label 340741-205 and apply over the Propane Conversion label. (See **Figure 15**) Date, name, and address of organization making this conversion are required.
2. Apply Conversion Rating Plate Label 340741-201 over the Propane Conversion label on outer door of furnace. (See **Figure 16**)
3. Apply Gas Control Conversion Label 340741-202 over Propane label on the gas valve. DO NOT use 340741-203, which is similar.



**Figure 15**

**Conversion Responsibility Label**

**THIS FURNACE WAS CONVERTED ON \_\_\_\_\_ TO NATURAL GAS**  
(DAY-MONTH-YEAR)  
**KIT NO.: KGCPN4401VSP**

**BY:**

(Name and address of organization making this conversion), which accepts the responsibility that this conversion has been properly made.

**CETTE FOURNAISE A ÉTÉ CONVERTED AU GAZ NATUREL LE \_\_\_\_\_**  
(JOUR-MOIS-ANNÉE)  
**DE L'ENSEMBLE N°.: KGCPN4401VSP**

**PAR:**

(Nom et adresse de l'organisme qui a effectué la conversion), qui accepte l'entière responsabilité de la conversion.

340741-205 REV.A



**Figure 16**

**Conversion Kit Rating Plate**

**CONVERSION KIT RATING PLATE - CARRIER CORPORATION**

THIS APPLIANCE HAS BEEN CONVERTED TO USE NATURAL GAS FOR FUEL. REFER TO KIT INSTRUCTIONS FOR CONVERSION PROCEDURES. USE PARTS SUPPLIED BY CARRIER CORPORATION AND INSTALLED BY QUALIFIED PERSONNEL. SEE EXISTING RATING PLATE FOR APPLIANCE MODEL NO. AND INPUT RATING.

NOTE: Furnace gas input rate on rating plate is for installations up to 2000 ft. (610m) above sea level. In U.S.A. the input rating for altitudes above 2000 ft. (610m) must be derated by 2% for each 1000 ft. (305m) above sea level. In Canada the input rating must be derated (per chart below) for altitudes of 2000 ft. (610m) to 4500 ft. (1372m) above sea level.

KIT NO.: KGCPN4401VSP (SUPERSEDES: KGAPN4401VSP, KGBPN4401VSP)

FUEL USED: NATURAL GAS

APPLIANCE MODELS	USA % DERATE PER 1000 FT.	CANADA % DERATE FOR 2000-4500 FT.	NATURAL GAS PRESSURE		IN. W.C. (PO C.E.)	PA
						Max. Inlet Gas Pressure (Press. Max. D'Admission De Gaz)
			Min. Inlet Gas Pressure (Press. Min. D'Admission De Gaz)	4.5	1,121	
			(For Purpose of Input Adjustment) (Pour L'Adjustment D'Entree)			
59MN7 987M	2%	5%	<b>ALTITUDE</b>			
			Manifold Pressure 0-2,000 ft. (0 - 610 m)	Max Heat 3.2 - 3.8	797 - 946	
			Pression Tubulure 2,000 - 10,000 ft. (610 - 3050 m)	Min Heat 0.50 - 0.60	125 - 162	
			Refer to Installation Manual Respecter les Instruction D'Installation			



340741-201 REV.A

**59TN6A, 59TP6, 986TB, 926TA – Variable Speed, Two-Stage Gas Valve**

1. Verify SW1-2 on furnace control is turned "ON".
2. Jumper R and W/W1 thermostat connections to call for heat.
3. Check manifold orifices for gas leaks when main burners ignite.
4. Adjust gas manifold pressure. Refer to **Table 5**.
5. Remove caps that conceal the adjustment screws for gas valve regulators. (See **Figure 17**)
6. Adjust low-heat manifold pressure for natural gas. (See **Figure 17**)
7. Turn low-heat adjusting screw counterclockwise (out) to decrease input rate or clockwise (in) to increase input rate.

**NOTE:** When correct input is obtained, main burner flame should be clear blue, almost transparent (See **Figure 31**)

8. Jumper R, W/W1 and W2 on control center thermostat connections. This keeps furnace locked in high-heat operation.
9. Adjust high-heat manifold pressure for natural gas.
10. Turn high-heat adjusting screw counterclockwise (out) to decrease input rate or clockwise (in) to increase input rate.
11. Replace caps that conceal the gas valve regulator adjustment screws.

12. Remove jumper across R, W1, and W2 after high-heat adjustment to terminate call for heat.
13. Turn setup switch SW1-2 on furnace control to OFF position.
14. Turn furnace gas valve switch to OFF position.
15. Turn off furnace power supply.
16. Remove manometer and on some models remove pressure tap fitting.
17. On some models, apply pipe dope sparingly to end of 1/8-in. (3 mm) pipe plug and install in the manifold pressure tap opening. Or, on some models, tighten set screw on manifold tower pressure tap with a 3/32-in. hex wrench. (See **Figure 17**)
18. Turn furnace gas valve switch to ON position.
19. Turn on furnace power supply.
20. Set room thermostat to call for heat.
21. Check pressure tap plug for gas leaks when main burners ignite.
22. Check for correct burner flame.
23. After making the required manifold pressure adjustments, check and adjust the furnace temperature rise per the furnace installation instructions.

**CHECKOUT**

1. Observe unit operation through two complete heating cycles.
2. See Sequence of Operation in furnace Installation, Start-Up, and Operating Instructions.



3. Set room thermostat to desired temperature.

## LABEL APPLICATION

1. Fill in Conversion Responsibility Lab
- 2.
3. el 340741-205 and apply over the Propane Conversion label. (See **Figure 15**) Date, name, and address of organization making this conversion are required. Apply Conversion Rating Plate Label 340741-206 over the Propane Conversion label on outer door of furnace. (See **Figure 18**) Apply Gas Control Conversion Label 340741-202 over Propane label on the gas valve. DO NOT use 340741-203, which is similar.

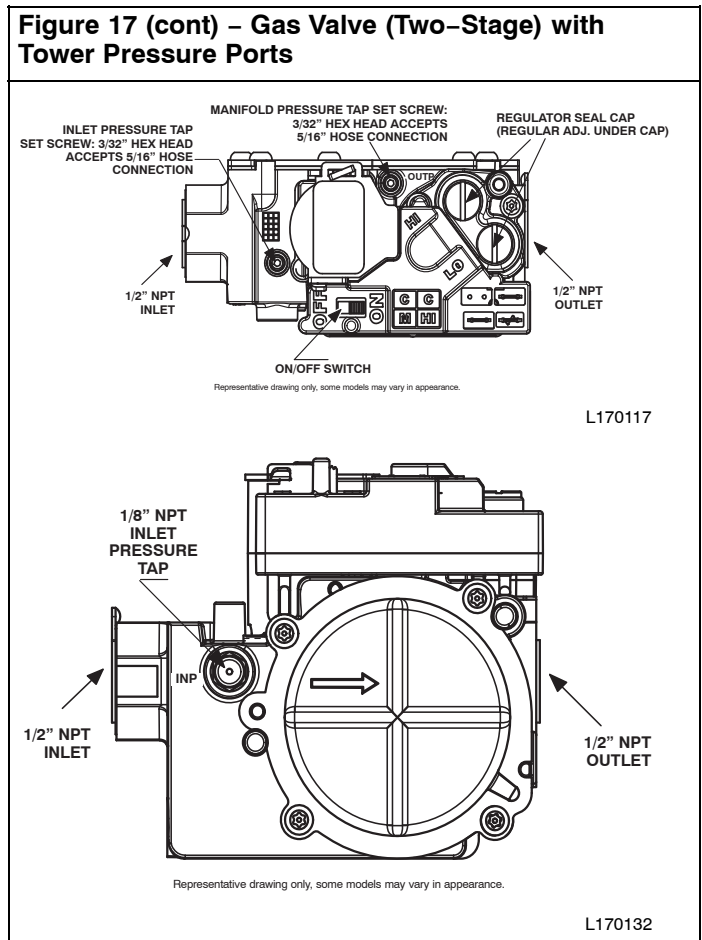
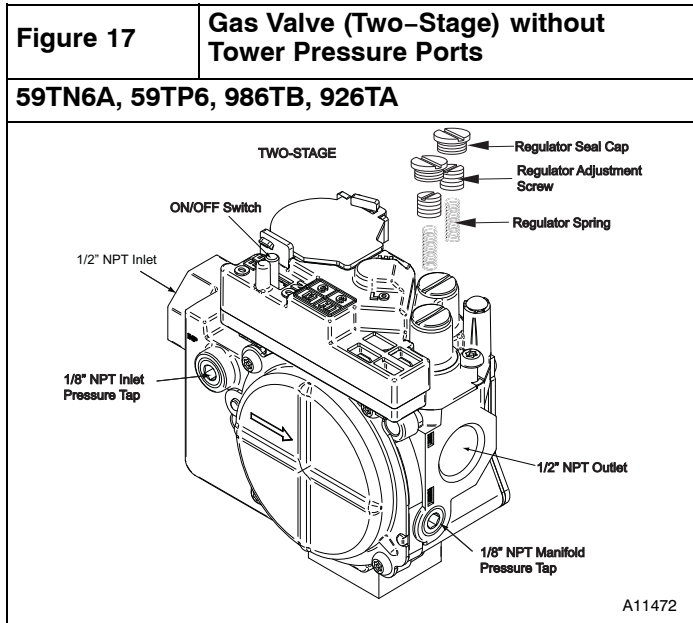

<b>Figure 18</b>	<b>Conversion Kit Rating Plate</b>
------------------	------------------------------------

**CONVERSION KIT RATING PLATE - CARRIER CORPORATION**

**THIS APPLIANCE HAS BEEN CONVERTED TO USE NATURAL GAS FOR FUEL. REFER TO KIT INSTRUCTIONS FOR CONVERSION PROCEDURES. USE PARTS SUPPLIED BY CARRIER CORPORATION AND INSTALLED BY QUALIFIED PERSONNEL. SEE EXISTING RATING PLATE FOR APPLIANCE MODEL NO. AND INPUT RATING.**

**NOTE:** Furnace gas input rate on rating plate is for installations up to 2000 ft. (610m) above sea level. In U.S.A. the input rating for altitudes above 2000 ft. (610m) must be derated by 2% for each 1000 ft. (305m) above sea level. In Canada the input rating must be derated (per chart below) for altitudes of 2000 ft. (610m) to 4500 ft. (1372m) above sea level.

**KIT NO.:** KGCPN4401VSP (SUPERSEDES: KGAPN4401VSP, KGBPN4401VSP) **FUEL USED: NATURAL GAS**

APPLIANCE MODELS	USA % DERATE PER 1000 FT.	CANADA % DERATE FOR 2000-4500 FT.	NATURAL GAS PRESSURE				
			IN. W.C. (PO C.E.)	PA			
<b>59TP6, 59TN6, 926T, 986T PG96V_T</b>	2%	5%	Max. Inlet Gas Pressure (Press. Max. D'Admission De Gaz)			13.6	3,386
			Min. Inlet Gas Pressure (Press. Min. D'Admission De Gaz)			4.5	1,121
			(For Purpose of Input Adjustment) (Pour L'Adjustment D'Entree)				
			<b>ALTITUDE</b>				
Manifold Pressure			0-2,000 ft. (0 - 610 m)	<b>High Heat</b>	3.2 - 3.8	797 - 946	
			<b>Low Heat</b>		1.4 - 1.8	349 - 448	
Pression Tubulure			2,000 - 10,000 ft. (610 - 3050 m) Refer to Installation Manual Respecter les Instruction D'Installation				

340741-206 REV. A

## SECTION 2 NON CONDENSING FURNACES

Table 6	MODEL NUMBERS BEGINNING WITH:	
58CTW		314AAV
58CTY		314JAV
58CVA		315AAV
58CVX		315JAV
PG8MV		PG8JV

### INSTALLATION

#### ! WARNING

##### FIRE, EXPLOSION, ELECTRICAL SHOCK, AND CARBON MONOXIDE POISONING HAZARD

Failure to follow this warning could result in personal injury or death.

This conversion kit shall be installed by a qualified service agency in accordance with the manufacturer's instructions and all applicable codes and requirements of the authority having jurisdiction. If the information in these instructions is not followed exactly, a fire, explosion, or production of carbon monoxide could result causing property damage, personal injury, or loss of life. The qualified service agency is responsible for the proper installation of this furnace with this kit. The installation is not proper and complete until the operation of the converted appliance is checked as specified in the manufacturer's instructions supplied with the kit.

#### ! AVERTISSEMENT

##### LE FEU, L'EXPLOSION, CHOC ELECTRIQUE, ET MONOXYDE DE CARBONE EMPOISONNER

Cette trousse de conversion doit être installée par un service d'entretien qualifié, selon les instructions du fabricant et selon toutes les exigences et tous les codes pertinents de l'autorité compétente. Assurez-vous de bien suivre les instructions dans cette notice pour réduire au minimum le risque d'incendie, d'explosion ou la production de monoxyde de carbone pouvant causer des dommages matériels, de blessure ou la mort. Le service d'entretien qualifié est responsable de l'installation de cette trousse. L'installation n'est pas adéquate ni complète tant que le bon fonctionnement de l'appareil converti n'a pas été vérifié selon les instructions du fabricant fournies avec la trousse.

#### ! WARNING

##### FIRE, EXPLOSION, ELECTRICAL SHOCK AND CARBON MONOXIDE POISONING HAZARD

Failure to follow instructions could result in personal injury, death or property damage.

Improper installation, adjustment, alteration, service, maintenance, or use can cause carbon monoxide poisoning, explosion, fire, electrical shock, or other conditions, which could result in personal injury or death. Consult your distributor or branch for information or assistance. The qualified installer or agency must use only factory-authorized kits or accessories when servicing this product.

#### ! WARNING

##### FIRE, EXPLOSION, ELECTRICAL SHOCK HAZARD

Failure to follow this warning could result in personal injury, death or property damage.

Gas supply **MUST** be shut off before disconnecting electrical power and proceeding with conversion.

#### ! WARNING

##### ELECTRICAL SHOCK, FIRE OR EXPLOSION HAZARD

Failure to follow this warning could result in personal injury, death or property damage.

Before installing, modifying, or servicing system, main electrical disconnect switch must be in the OFF position and install a lockout tag. There may be more than one disconnect switch. Lock out and tag switch with a suitable warning label. Verify proper operation after servicing.

1. Set room thermostat to lowest setting or "OFF".
2. Disconnect power at external disconnect, fuse or circuit breaker.
3. Turn off gas at external shut-off or gas meter.
4. Remove outer doors and set aside.
5. Turn electric switch on gas valve to OFF.

**Figure 19** Representative Furnace Drawing

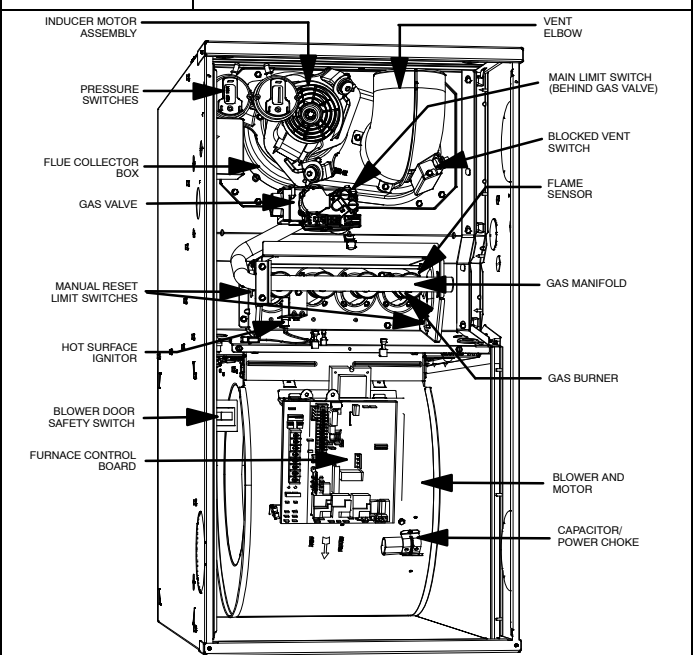

# MANIFOLD/ORIFICE/BURNER REMOVAL



## CAUTION

### UNIT OPERATION HAZARD

Failure to follow this caution may result in unit damage or improper operation.

Label all wires prior to disconnection when servicing controls.



## PRUDENCE

### D'EQUIPEMENT D'OPERATION

Toute erreur de câblage peut être une source de danger et de panne.

Lors des opérations d'entretien des commandes, étiqueter tous les fils avant de les déconnecter.

**NOTE:** Use a back-up wrench on the gas valve to prevent the valve from rotating on the manifold or damaging the mounting to the burner box. (See **Figure 20** and **Figure 21**)

1. Disconnect the gas pipe from gas valve and remove pipe from the furnace casing.
2. Disconnect the connector harness from gas valve. Disconnect wires from Hot Surface Igniter (HSI) and Flame Sensor. Disconnect the two wires from the low gas pressure switch (LGPS) located on the gas valve.
3. Support the manifold and remove the four (4) screws that secure the manifold assembly to the burner box and set aside.
4. Note the location of the green/yellow wire ground wire for re-assembly later.
5. Slide one-piece burner assembly out of slots on sides of burner box.
6. Remove the flame sensor from the burner assembly.
7. Remove the orifices from the manifold and discard.

**Figure 20** 80% Burners

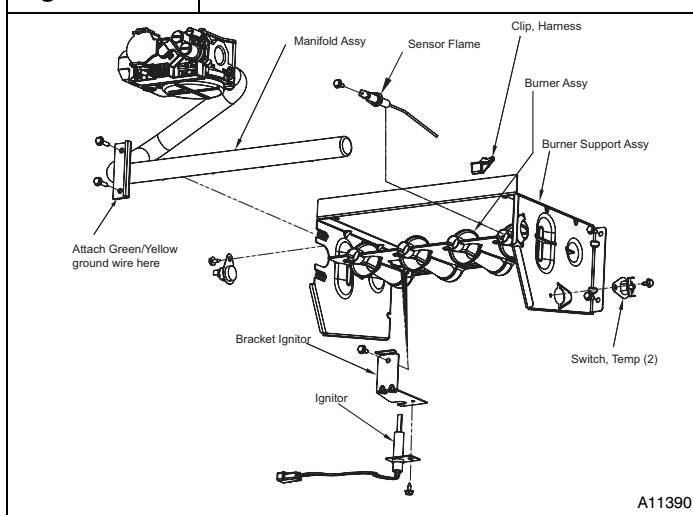

**Figure 21** Burner Assembly

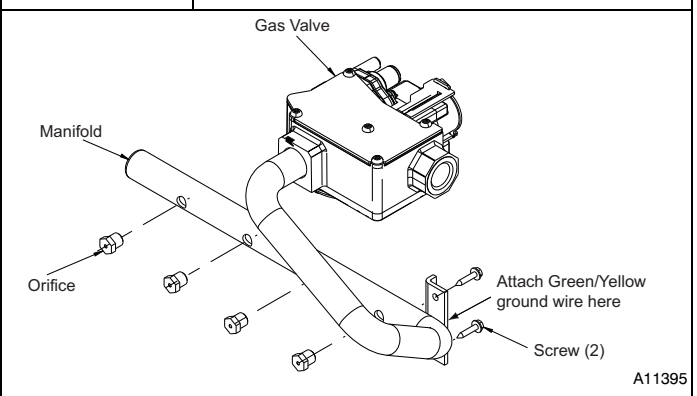

## NOx DEVICE INSTALLATION (when required)

The following models must have NOx baffles installed (58CVX, 58CTY, 314JAV, 315JAV, and PG8JV). NOx baffles are not included in this kit and must be ordered separately or reused if retained from original conversion to Propane.

For NOx device installation, follow these additional steps:

1. Remove the screw underneath the heat exchanger inlet that secures the NOx device in the heat exchanger. (See **Figure 22**)
2. Use a pair of needle nose pliers to install the NOx device.
3. Squeeze the sides of the device, if necessary, to install in the heat exchanger.
4. Re-install screw in hole underneath heat exchanger inlet.

**NOTE:** It is very IMPORTANT to reinstall the NOx bracket mounting screw.

5. Repeat steps for each heat exchanger.

**Figure 22** NOx Device

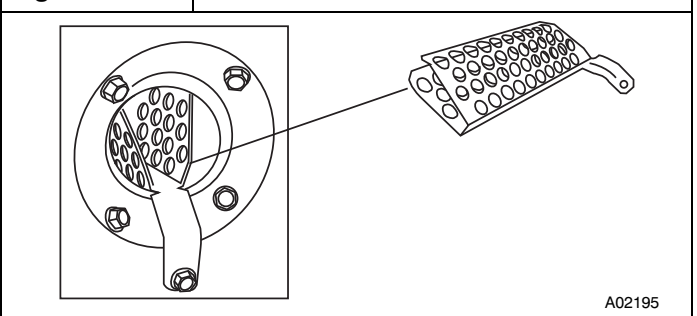

## ORIFICE SELECTION/DERATE



## CAUTION

### UNIT DAMAGE HAZARD

Failure to follow this caution may result in unit damage.

DO NOT re-drill burner orifices. Improper drilling may result in burrs, out-of-round holes, etc. Obtain new orifices if orifice size must be changed. (See **Figure 23**)

**Figure 23** Burner Orifice

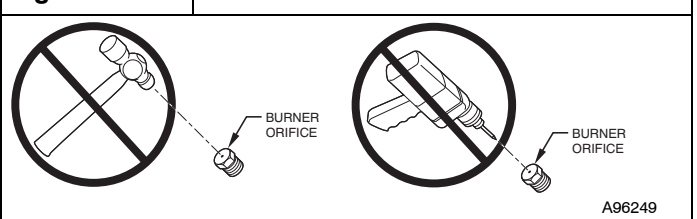

Determine natural gas orifice size and manifold pressures for correct input at installed altitude by using **Table 7**.

**NOTE:** All models in all positions except Low NOx models in downflow and horizontal positions use Table 7 (22,000 Btuh per burner). Low NOx models in downflow or horizontal positions must use Table 8 (21,000 Btuh per burner). See input listed on rating plate.

1. Obtain yearly heat-value average (at installed altitude) for local gas supply.
2. Obtain yearly specific-gravity average for local gas supply.
3. Find installation altitude in **Table 7**.

**NOTE:** For Canada altitudes of 2000 to 4500 ft., use U.S.A. Altitudes of 2001 to 3000 ft. In **Table 7**.

4. Find closest natural gas heat value and specific gravity in **Table 7**.
5. Follow heat-value line and specific-gravity line to point of intersection to find orifice size and high and low manifold pressure settings.

Furnace gas input rate on furnace rating plate is for installations at altitudes up to 2000 ft. (610 M).

**In the U.S.A.;** the input rating for altitudes above 2000 ft. (610 M) must be reduced by 4 percent for each 1000 ft. (305 M) above sea level.

**In Canada,** the input rating must be derated by 10 percent for altitudes of 2000 ft. to 4500 ft. (610 M to 1372 M) above sea level.

The Conversion Kit Rating Plate accounts for high altitude derate.

## INSTALL ORIFICES

1. Install main burner orifices. DO NOT use Teflon tape. Finger-tighten orifices at least one full turn to prevent cross-threading, then tighten with wrench.
2. There are enough orifices in each kit for largest furnace. Discard extra orifices.

**NOTE:** DO NOT reinstall the manifold at this time.

Table 7		Orifice Size and Manifold Pressure (in.w.c.) for Gas Input Rate (Tabulated Data Based on 22,000 Btuh High-Heat/14,500 Btuh for Low-Heat per Burner, Derated 4 Percent for Each 1000 Ft. (305 M) Above Sea Level)									
		ALTITUDE RANGE FT. (M)	AVG. GAS HEAT VALUE (BTUH/CU FT.)	SPECIFIC GRAVITY OF NATURAL GAS							
				0.58		0.60		0.62		0.64	
		Orifice No.	Manifold Pressure High/Low	Orifice No.	Manifold Pressure High/Low	Orifice No.	Manifold Pressure High/Low	Orifice No.	Manifold Pressure High/Low		
USA	0 to 2000 (0 to 610)	900	42	3.5/1.5	42	3.6/1.6	42	3.7/1.6	41	3.5/1.5	
		925	42	3.3/1.4	42	3.4/1.5	42	3.5/1.5	42	3.7/1.6	
		950	43	3.8/1.7	42	3.3/1.4	42	3.4/1.5	42	3.5/1.5	
		975	43	3.6/1.6	43	3.8/1.6	42	3.2/1.4	42	3.3/1.4	
		1000	43	3.5/1.5	43	3.6/1.6	43	3.7/1.6	43	3.8/1.7	
		1025	43	3.3/1.4	43	3.4/1.5	43	3.5/1.5	43	3.6/1.6	
		1050	44	3.6/1.6	43	3.2/1.4	43	3.4/1.5	43	3.5/1.5	
		1075	44	3.4/1.5	44	3.5/1.5	43	3.2/1.4	43	3.3/1.4	
		1100	44	3.3/1.4	44	3.4/1.5	44	3.5/1.5	43	3.2/1.4	
USA	2001 to 3000 (610 to 914)	800	42	3.4/1.5	42	3.5/1.5	42	3.6/1.6	42	3.7/1.6	
		825	42	3.2/1.4	42	3.3/1.4	42	3.4/1.5	42	3.5/1.5	
		850	43	3.7/1.6	43	3.8/1.6	42	3.2/1.4	42	3.3/1.4	
		875	43	3.5/1.5	43	3.6/1.6	43	3.7/1.6	43	3.8/1.7	
		900	43	3.3/1.4	43	3.4/1.5	43	3.5/1.5	43	3.6/1.6	
		925	44	3.5/1.5	43	3.2/1.4	43	3.3/1.4	43	3.4/1.5	
		950	44	3.4/1.5	44	3.5/1.5	44	3.6/1.6	43	3.2/1.4	
		975	44	3.2/1.4	44	3.3/1.4	44	3.4/1.5	44	3.5/1.5	
		1000	45	3.7/1.6	45	3.8/1.7	44	3.2/1.4	44	3.4/1.5	
USA	3001 to 4000 (914 to 1219)	775	42	3.2/1.4	42	3.3/1.4	42	3.4/1.5	42	3.5/1.5	
		800	43	3.6/1.6	43	3.8/1.6	42	3.2/1.4	42	3.3/1.4	
		825	43	3.4/1.5	43	3.5/1.5	43	3.7/1.6	43	3.8/1.6	
		850	43	3.2/1.4	43	3.3/1.4	43	3.4/1.5	43	3.6/1.5	
		875	44	3.5/1.5	44	3.6/1.6	43	3.3/1.4	43	3.4/1.5	
		900	44	3.3/1.4	44	3.4/1.5	44	3.5/1.5	43	3.2/1.4	
		925	45	3.8/1.6	44	3.2/1.4	44	3.3/1.5	44	3.4/1.5	
		950	46	3.8/1.6	45	3.7/1.6	45	3.8/1.7	44	3.3/1.4	

\* Orifice number 43 are factory installed

ALTITUDE RANGE FT. (M)		AVG. GAS HEAT VALUE (BTUH/CU FT.)	SPECIFIC GRAVITY OF NATURAL GAS							
			0.58		0.60		0.62		0.64	
			Orifice No.	Manifold Pressure High/ Low	Orifice No.	Manifold Pressure High/ Low	Orifice No.	Manifold Pressure High/ Low	Orifice No.	Manifold Pressure High/ Low
USA	4001 to 5000 (1219 to 1524)	750	43	3.6/1.6	43	3.8/1.6	42	3.2/1.4	42	3.3/1.4
		775	43	3.4/1.5	43	3.5/1.5	43	3.6/1.6	43	3.8/1.6
		800	43	3.2/1.4	43	3.3/1.4	43	3.4/1.5	43	3.5/1.5
		825	44	3.4/1.5	44	3.6/1.5	43	3.2/1.4	43	3.3/1.4
		850	44	3.2/1.4	44	3.4/1.5	44	3.5/1.5	44	3.6/1.6
		875	45	3.7/1.6	45	3.8/1.7	44	3.3/1.4	44	3.4/1.5
		900	46	3.7/1.6	46	3.8/1.7	45	3.7/1.6	44	3.2/1.4
		925	46	3.5/1.5	46	3.6/1.6	46	3.7/1.6	46	3.8/1.7
USA	5001 to 6000 (1524 to 1829)	725	43	3.4/1.5	43	3.5/1.5	43	3.6/1.6	43	3.7/1.6
		750	43	3.2/1.4	43	3.3/1.4	43	3.4/1.5	43	3.5/1.5
		775	44	3.4/1.5	44	3.5/1.5	43	3.2/1.4	43	3.3/1.4
		800	44	3.2/1.4	44	3.3/1.4	44	3.4/1.5	44	3.5/1.5
		825	46	3.8/1.7	45	3.8/1.6	44	3.2/1.4	44	3.3/1.4
		850	46	3.6/1.6	46	3.7/1.6	46	3.8/1.7	45	3.8/1.6
		875	47	3.8/1.7	46	3.5/1.5	46	3.6/1.6	46	3.7/1.6
		900	47	3.6/1.6	47	3.8/1.6	46	3.4/1.5	46	3.5/1.5
USA	6001 to 7000 (1829 to 2134)	675	43	3.4/1.5	43	3.5/1.5	43	3.6/1.6	43	3.7/1.6
		700	44	3.6/1.6	43	3.3/1.4	43	3.4/1.5	43	3.5/1.5
		725	44	3.4/1.5	44	3.5/1.5	44	3.6/1.6	43	3.2/1.4
		750	45	3.8/1.7	44	3.3/1.4	44	3.4/1.5	44	3.5/1.5
		775	46	3.7/1.6	45	3.7/1.6	45	3.8/1.7	44	3.2/1.4
		800	46	3.5/1.5	46	3.6/1.6	46	3.8/1.6	45	3.7/1.6
		825	47	3.7/1.6	46	3.4/1.5	46	3.5/1.5	46	3.6/1.6
		850	47	3.5/1.5	47	3.6/1.6	47	3.8/1.6	46	3.4/1.5
USA	7001 to 8000 (2134 to 2438)	650	44	3.6/1.6	43	3.2/1.4	43	3.4/1.5	43	3.5/1.5
		675	44	3.3/1.5	44	3.5/1.5	44	3.6/1.6	43	3.2/1.4
		700	45	3.8/1.6	44	3.2/1.4	44	3.3/1.4	44	3.4/1.5
		725	46	3.7/1.6	46	3.8/1.7	45	3.7/1.6	44	3.2/1.4
		750	46	3.4/1.5	46	3.6/1.5	46	3.7/1.6	46	3.8/1.6
		775	47	3.6/1.6	47	3.8/1.6	46	3.4/1.5	46	3.6/1.5
		800	47	3.4/1.5	47	3.5/1.5	47	3.7/1.6	47	3.8/1.6
		825	48	3.7/1.6	48	3.8/1.6	47	3.4/1.5	47	3.6/1.5
USA	8001 to 9000 (2438 to 2743)	625	44	3.3/1.5	44	3.5/1.5	44	3.6/1.6	43	3.2/1.4
		650	45	3.7/1.6	44	3.2/1.4	44	3.3/1.4	44	3.4/1.5
		675	46	3.6/1.6	46	3.8/1.6	45	3.7/1.6	45	3.8/1.7
		700	47	3.8/1.7	46	3.5/1.5	46	3.6/1.6	46	3.7/1.6
		725	47	3.6/1.6	47	3.7/1.6	47	3.8/1.7	46	3.5/1.5
		750	48	3.8/1.7	47	3.5/1.5	47	3.6/1.6	47	3.7/1.6
		775	48	3.6/1.5	48	3.7/1.6	48	3.8/1.7	47	3.5/1.5
USA	9001 to 10,000 2743 to 3048)	600	45	3.7/1.6	45	3.8/1.7	44	3.3/1.4	44	3.4/1.5
		625	46	3.6/1.6	46	3.7/1.6	46	3.8/1.7	45	3.8/1.6
		650	47	3.8/1.6	46	3.4/1.5	46	3.6/1.5	46	3.7/1.6
		675	47	3.5/1.5	47	3.6/1.6	47	3.7/1.6	46	3.4/1.5
		700	48	3.7/1.6	48	3.8/1.7	47	3.5/1.5	47	3.6/1.6
		725	48	3.5/1.5	48	3.6/1.6	48	3.7/1.6	48	3.8/1.7

\* Orifice number 43 are factory installed

ALTITUDE RANGE FT. (M)		AVG. GAS HEAT VALUE (BTUH/CU FT.)	SPECIFIC GRAVITY OF NATURAL GAS							
			0.58		0.60		0.62		0.64	
			Orifice No.	Manifold Pressure High/Low	Orifice No.	Manifold Pressure High/Low	Orifice No.	Manifold Pressure High/Low	Orifice No.	Manifold Pressure High/Low
USA	0 to 2000 (0 to 610)	900	42	3.2/1.5	42	3.3/1.6	42	3.4/1.6	42	3.5/1.7
		925	43	3.7/1.8	43	3.8/1.8	42	3.2/1.5	42	3.3/1.6
		950	43	3.5/1.7	43	3.6/1.7	43	3.7/1.8	43	3.8/1.8
		975	43	3.3/1.6	43	3.4/1.6	43	3.5/1.7	43	3.7/1.7
		1000	44	3.6/1.7	43	3.3/1.6	43	3.4/1.6	43	3.5/1.7
		1025	44	3.4/1.6	44	3.6/1.7	43	3.2/1.5	43	3.3/1.6
		1050	44	3.3/1.6	44	3.4/1.6	44	3.5/1.7	43	3.2/1.5
		1075	45	3.8/1.8	44	3.2/1.5	44	3.3/1.6	44	3.4/1.6
		1100	46	3.8/1.8	45	3.7/1.8	44	3.2/1.5	44	3.3/1.6
USA	2001 to 3000 (610 to 914)	800	43	3.8/1.8	42	3.2/1.5	42	3.3/1.6	42	3.4/1.6
		825	43	3.5/1.7	43	3.7/1.7	43	3.8/1.8	42	3.2/1.5
		850	43	3.3/1.6	43	3.5/1.6	43	3.6/1.7	43	3.7/1.8
		875	43	3.2/1.5	43	3.3/1.6	43	3.4/1.6	43	3.5/1.7
		900	44	3.4/1.6	44	3.5/1.7	43	3.2/1.5	43	3.3/1.6
		925	44	3.2/1.5	44	3.3/1.6	44	3.5/1.6	44	3.6/1.7
		950	45	3.7/1.8	45	3.8/1.8	44	3.3/1.6	44	3.4/1.6
		975	46	3.7/1.8	46	3.8/1.8	45	3.8/1.8	44	3.2/1.5
		1000	46	3.5/1.7	46	3.6/1.7	46	3.8/1.8	45	3.7/1.8
USA	3001 to 4000 (914 to 1219)	775	43	3.5/1.7	43	3.7/1.7	43	3.8/1.8	42	3.2/1.5
		800	43	3.3/1.6	43	3.4/1.6	43	3.5/1.7	43	3.7/1.7
		825	44	3.6/1.7	43	3.2/1.5	43	3.3/1.6	43	3.4/1.6
		850	44	3.4/1.6	44	3.5/1.7	44	3.6/1.7	43	3.2/1.5
		875	45	3.8/1.8	44	3.3/1.6	44	3.4/1.6	44	3.5/1.7
		900	46	3.8/1.8	45	3.8/1.8	44	3.2/1.5	44	3.3/1.6
		925	46	3.6/1.7	46	3.7/1.8	45	3.7/1.8	45	3.8/1.8
		950	46	3.4/1.6	46	3.5/1.7	46	3.7/1.7	46	3.8/1.8
USA	4001 to 5000 (1219 to 1524)	750	43	3.3/1.6	43	3.4/1.6	43	3.5/1.7	43	3.6/1.7
		775	44	3.6/1.7	43	3.2/1.5	43	3.3/1.6	43	3.4/1.6
		800	44	3.3/1.6	44	3.4/1.6	44	3.6/1.7	43	3.2/1.5
		825	45	3.8/1.8	44	3.2/1.5	44	3.4/1.6	44	3.5/1.6
		850	46	3.8/1.8	45	3.7/1.8	45	3.8/1.8	44	3.3/1.6
		875	46	3.5/1.7	46	3.7/1.7	46	3.8/1.8	45	3.7/1.8
		900	47	3.8/1.8	46	3.5/1.7	46	3.6/1.7	46	3.7/1.8
		925	47	3.6/1.7	47	3.7/1.8	47	3.8/1.8	46	3.5/1.7
USA	5001 to 6000 (1524 to 1829)	725	44	3.5/1.7	43	3.2/1.5	43	3.3/1.6	43	3.4/1.6
		750	44	3.3/1.6	44	3.4/1.6	44	3.5/1.7	43	3.2/1.5
		775	45	3.7/1.8	44	3.2/1.5	44	3.3/1.6	44	3.4/1.6
		800	46	3.7/1.8	46	3.8/1.8	45	3.8/1.8	44	3.2/1.5
		825	46	3.5/1.7	46	3.6/1.7	46	3.7/1.8	46	3.8/1.8
		850	47	3.7/1.8	47	3.8/1.8	46	3.5/1.7	46	3.6/1.7
		875	47	3.5/1.7	47	3.6/1.7	47	3.7/1.8	46	3.4/1.6
		900	48	3.8/1.8	47	3.4/1.6	47	3.5/1.7	47	3.7/1.7
USA	6001 to 7000 (1829 to 2134)	675	44	3.5/1.7	43	3.2/1.5	43	3.3/1.6	43	3.4/1.6
		700	44	3.3/1.6	44	3.4/1.6	44	3.5/1.7	43	3.2/1.5
		725	45	3.7/1.8	45	3.8/1.8	44	3.3/1.6	44	3.4/1.6
		750	46	3.6/1.7	46	3.8/1.8	45	3.7/1.8	45	3.8/1.8
		775	46	3.4/1.6	46	3.5/1.7	46	3.6/1.7	46	3.8/1.8
		800	47	3.6/1.7	47	3.8/1.8	46	3.4/1.6	46	3.5/1.7
		825	47	3.4/1.6	47	3.5/1.7	47	3.6/1.7	47	3.8/1.8
		850	48	3.7/1.7	48	3.8/1.8	47	3.4/1.6	47	3.5/1.7
USA	7001 to 8000 (2134 to 2438)	650	44	3.3/1.6	44	3.4/1.6	44	3.5/1.7	43	3.2/1.5
		675	45	3.7/1.8	45	3.8/1.8	44	3.3/1.6	44	3.4/1.6
		700	46	3.6/1.7	46	3.7/1.8	46	3.8/1.8	45	3.8/1.8
		725	47	3.8/1.8	46	3.5/1.7	46	3.6/1.7	46	3.7/1.8
		750	47	3.5/1.7	47	3.7/1.8	47	3.8/1.8	46	3.5/1.6
		775	48	3.8/1.8	47	3.4/1.6	47	3.6/1.7	47	3.7/1.7
		800	48	3.6/1.7	48	3.7/1.8	48	3.8/1.8	47	3.4/1.6
		825	48	3.3/1.6	48	3.5/1.6	48	3.6/1.7	48	3.7/1.8

ALTITUDE RANGE FT. (M)		AVG. GAS HEAT VALUE (BTUH/CU FT.)	SPECIFIC GRAVITY OF NATURAL GAS							
			0.58		0.60		0.62		0.64	
			Orifice No.	Manifold Pressure High/Low	Orifice No.	Manifold Pressure High/Low	Orifice No.	Manifold Pressure High/Low	Orifice No.	Manifold Pressure High/Low
USA	8001 to 9000 (2438 to 2743)	625	45	3.7/1.8	45	3.8/1.8	44	3.3/1.6	44	3.4/1.6
		650	46	3.6/1.7	46	3.7/1.8	46	3.8/1.8	45	3.8/1.8
		675	47	3.8/1.8	46	3.4/1.6	46	3.5/1.7	46	3.7/1.7
		700	47	3.5/1.7	47	3.6/1.7	47	3.7/1.8	46	3.4/1.6
		725	48	3.7/1.8	48	3.8/1.8	47	3.5/1.7	47	3.6/1.7
		750	48	3.5/1.7	48	3.6/1.7	48	3.7/1.8	48	3.8/1.8
		775	49	3.8/1.8	48	3.4/1.6	48	3.5/1.7	48	3.6/1.7
USA	9001 to 10,000 (2743 to 3048)	600	46	3.6/1.7	46	3.7/1.8	46	3.8/1.8	45	3.7/1.8
		625	47	3.7/1.8	47	3.8/1.8	46	3.5/1.7	46	3.6/1.7
		650	47	3.4/1.6	47	3.6/1.7	47	3.7/1.8	47	3.8/1.8
		675	48	3.6/1.7	48	3.8/1.8	47	3.4/1.6	47	3.5/1.7
		700	48	3.4/1.6	48	3.5/1.7	48	3.6/1.7	48	3.7/1.8
		725	49	3.7/1.8	49	3.8/1.8	48	3.4/1.6	48	3.5/1.7

## REMOVE MIXER SCREWS FROM THE BURNERS

Each burner contains a mixer screw that must be removed. Refer to **Figure 24** for the mixer screw location

1. Remove the mixer screws from the burners.

**NOTE:** It is not necessary to plug the hole in the burner when the mixer screws are removed.

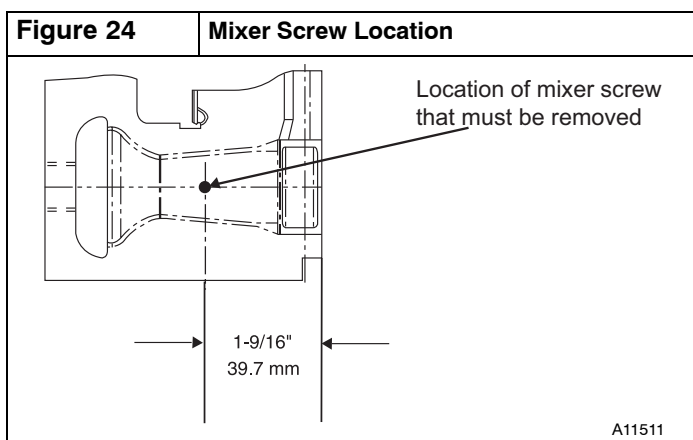

## REINSTALL BURNER ASSEMBLY

To reinstall burner assembly:

1. Attach flame sensor to burner assembly.
2. Insert one-piece burner in slot on sides of burner box and slide burner back in place.
3. Reattach HSI wires to HSI.
4. Verify igniter to burner alignment. (See **Figure 25** and **Figure 26**)
5. Verify igniter to burner alignment.

6. For Silicon Nitride igniters, (See **Figure 25** and **Figure 26**).
7. For Silicon Carbide igniters, see **Figure 27**.
8. Reattach Flame sensor wire to Flame Sensor.

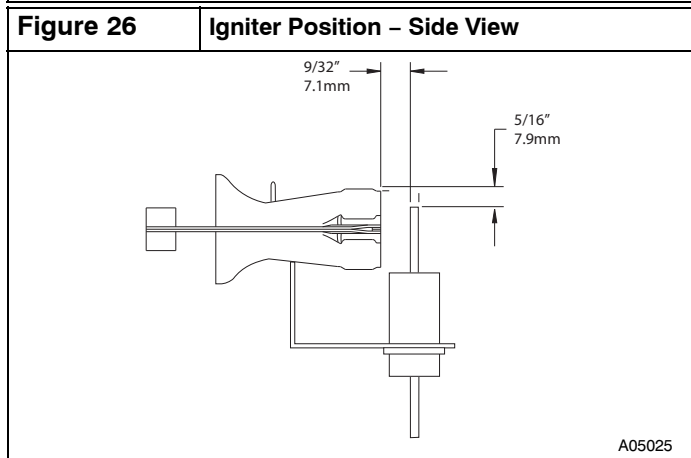
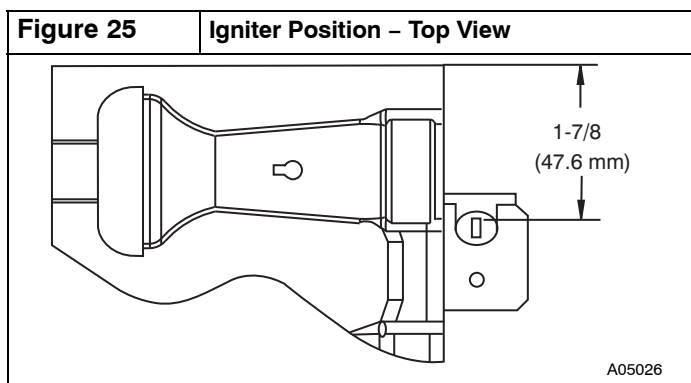

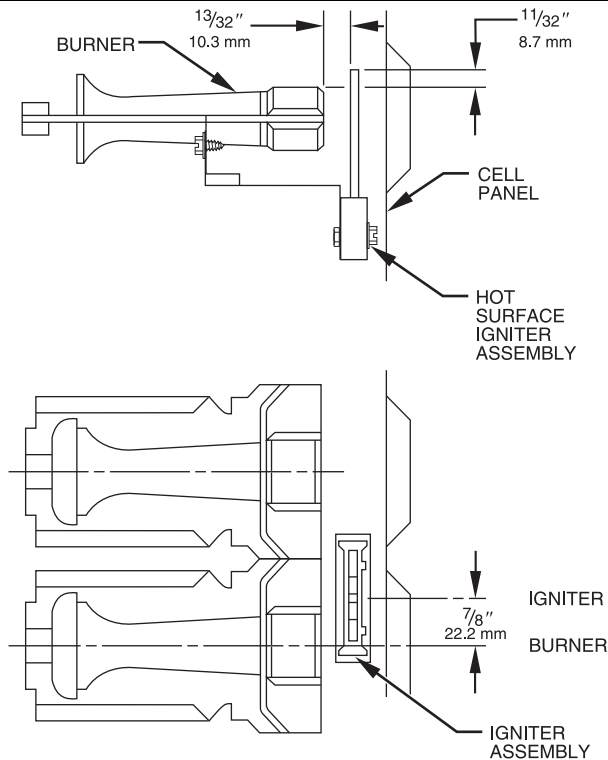

**Figure 27****Silicon Carbide Igniters**

A93347

**CONVERT GAS VALVE****CAUTION****UNIT DAMAGE HAZARD**

Failure to follow this caution may result in unit damage

The gas valve must be converted and pre-adjusted before operating on natural gas. If not converted and pre-adjusted, sooting and corrosion will occur leading to early heat exchanger failure.

**WARNING****FIRE, EXPLOSION, ELECTRICAL SHOCK HAZARD**

Failure to follow this warning could result in personal injury, death or property damage.

Gas supply **MUST** be shut off before disconnecting electrical power and proceeding with conversion.

**WARNING****ELECTRICAL SHOCK, FIRE OR EXPLOSION HAZARD**

Failure to follow this warning could result in personal injury, death or property damage.

Before installing, modifying, or servicing system, main electrical disconnect switch must be in the OFF position and install a lockout tag. There may be more than one disconnect switch. Lock out and tag switch with a suitable warning label. Verify proper operation after servicing.

**NOTE:** For the 2-stage furnaces with a Series J and Series G gas valve (see **Figure 28**), they **MUST** have both regulator springs replaced and the gas valve **MUST** be pre-adjusted. For older model 2-stage furnaces with a Series E gas valve (see **Figure 28**), they **DO NOT** need to have the regulator springs replaced in the gas valve, but the regulators in the gas valve must be pre-adjusted for natural applications.

**For J and G valves See Figure 28.**

1. Refer to **Figure 28**.
2. Be sure gas and electrical supplies to furnace are off.
3. Remove caps that conceal adjustment screws for high-heat and low-heat stage gas valve regulators. (See **Figure 28**)
4. Remove the high-heat and low-heat regulator adjustment screws.
5. Remove the high-heat and low-heat Propane gas regulator springs (white).
6. Install the high-heat and low-heat natural gas regulator springs (silver).
7. Install the high-heat and low-heat regulator adjustment screws.
8. Turn high-heat stage adjusting screw clockwise (in) 12 full turns. This will increase the manifold pressure closer to the natural high-heat set point. (See **Figure 28**)
9. Turn low-heat stage adjusting screw clockwise (in) 9.5 full turns. This will increase the manifold pressure closer to the natural low-heat set point. (See **Figure 28**)
10. **DO NOT** install regulator seal caps at this time.

**For E valves see Figure 28.**

1. Be sure gas and electrical supplies to furnace are off.
2. Remove caps that conceal adjustment screws for high- and low-heat stage gas valve regulators. (See **Figure 28**)
3. Turn low-heat stage adjusting screw (3/32-in. [2 mm] hex Allen screw) counter clockwise (outwards) 1 full turn. This will decrease the manifold pressure closer to the natural low-heat set point.
4. Turn high-heat stage adjusting screw (3/32-in. [2 mm] hex Allen screw) counter clockwise (outwards) 2 full turns. This will decrease the manifold pressure closer to the natural high-heat set point.
5. **DO NOT** install regulator seal caps at this time.

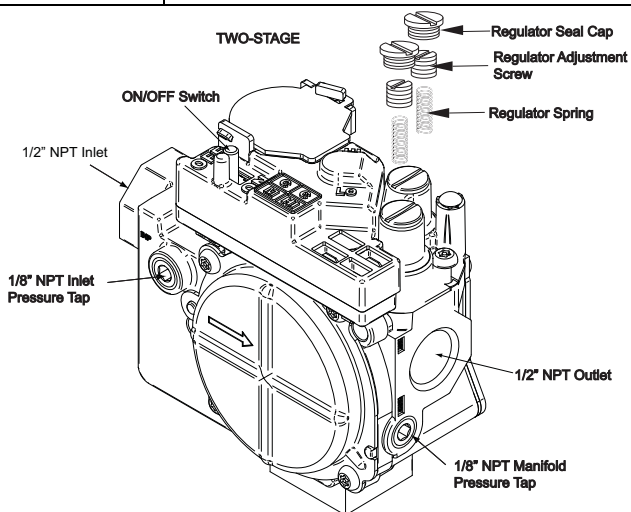
**Figure 28****Two-Stage Gas valve**

A11472

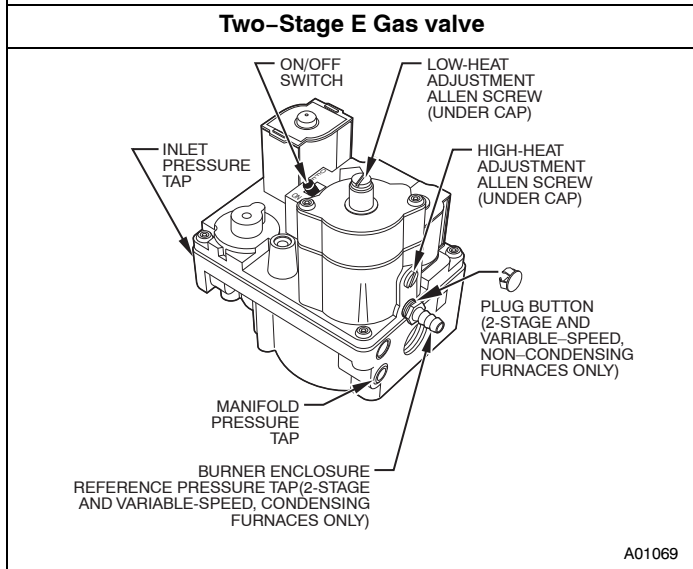
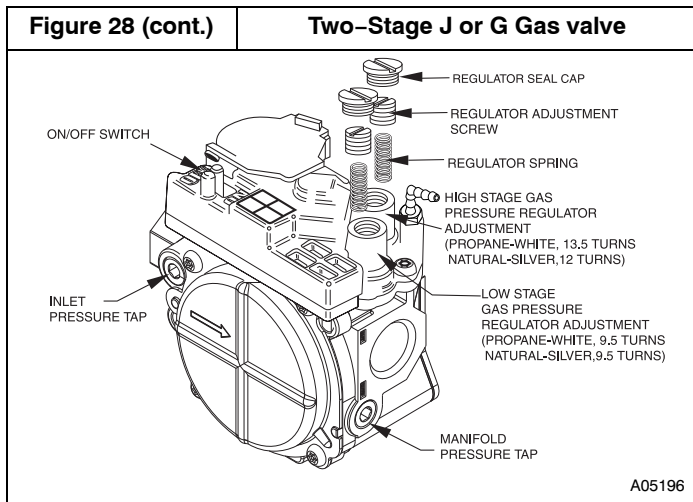

**WARNING**

**FIRE AND EXPLOSION HAZARD**

Failure to follow this warning could result in personal injury and/or death.

NEVER test for gas leaks with an open flame. Use a commercially available soap solution made specifically for the detection of leaks to check all connections. A fire or explosion may result causing property damage, personal injury or loss of life.

## REMOVE LOW GAS PRESSURE SWITCH

1. Be sure main gas and electric supplies to furnace are off.
2. Remove low-gas pressure switch, brass street 90° elbow and 2-in. (50.8 mm) brass nipple from the gas valve inlet pressure tap. (See **Figure 29**)

**NOTE:** DO NOT use Teflon tape.

3. Apply pipe dope sparingly to the 1/8-in. (3 mm) NPT pipe plug and install the 1/8-in. (3 mm) tapped inlet pressure tap opening in the gas valve. DO NOT over-tighten. Check for gas leaks after gas supply has been turned on.

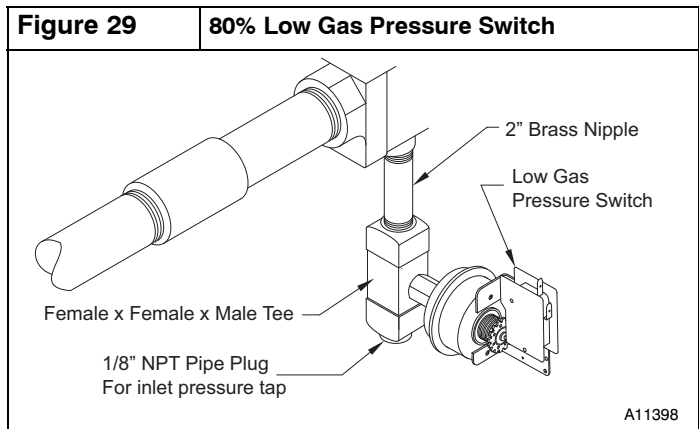

## INSTALL MANIFOLD

1. Align the orifices in the manifold assembly with the support rings on the end of the burner.
2. Insert the orifices in the support rings of the burners. Manifold mounting tabs should fit flush against the burner box.

**NOTE:** If manifold does not fit flush against the burner box, the burners are not fully seated forward. Remove the manifold and check burner positioning in the burner box assembly.

3. Attach the green/yellow wire and ground terminal to one of the manifold mounting screws.
4. Install the remaining manifold mounting screws.
5. Connect the wires to the flame sensor and hot surface igniter.
6. Connect the connector harness to gas valve.
7. Rewire unit low pressure switch (LPS) as follows:
  - a. Trace one of the orange wires previously disconnected from the LGPS back to the NO terminals of the LPS.
  - b. Trace the other orange wire previously disconnected from the LGPS back to its splice connection with the yellow wire of the furnace wire harness. Disconnect and discard this orange wire and the splice connection.
  - c. Connect the yellow wire of the furnace wire harness (see "b" above) to the NO terminal of the LPS.
  - d. Refer to the furnace wiring diagram ensure proper location of wires.

**NOTE:** DO NOT use Teflon tape.

8. Insert the gas pipe through the grommet in the casing. Apply a thin layer of pipe dope to the threads fo the pipe and thread the pipe into the gas valve.

**NOTE:** Use a back-up wrench on the gas valve to prevent the valve from rotating on the manifold or damaging the mounting to the burner box.

9. With a back-up wrench on the inlet boss of the gas valve, finish tightening the gas pipe to the gas valve.
10. Turn gas on at electric switch on gas valve.

## CHECK INLET GAS PRESSURE

**CAUTION**

**UNIT DAMAGE HAZARD**

Failure to follow this caution may result in unit damage.

DO NOT operate furnace more than one minute to check inlet gas pressure, as conversion is not complete at this time.

**NOTE:** This kit is to be used only when inlet gas pressure is between 4.5-in. w.c. and 13.6-in. w.c.

1. Verify manometer is connected to inlet pressure tap on gas valve.

2. Turn on furnace power supply.
3. Turn gas supply manual shutoff valve to ON position.
4. Turn furnace gas valve switch to ON position.
5. Turn Setup Switch SW1–2 on furnace control ON (See Figure 30)

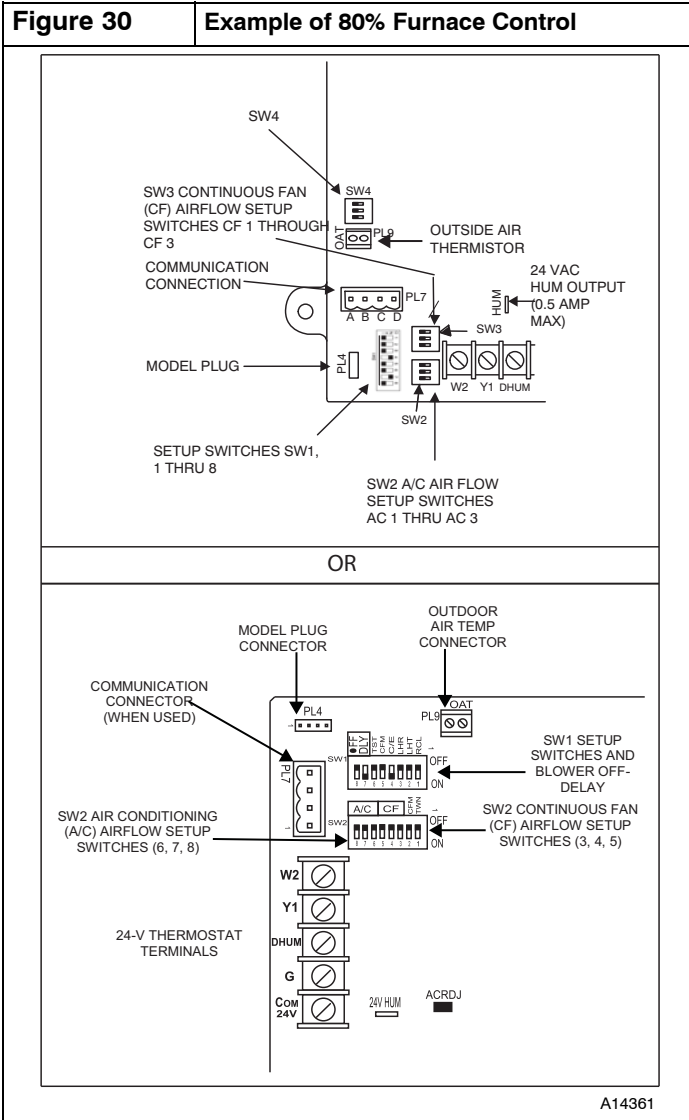

6. Jumper R–W/W1 and R–W2 thermostat connections on control.
7. When main burners ignite, confirm inlet gas pressure is between 4.5–in. w.c. and 13.6–in. w.c.
8. Remove jumper across R–W/W1 and R–W2 thermostat connections to terminate call for heat.
9. Turn furnace gas valve switch to OFF position.
10. Turn gas supply manual shutoff valve to OFF position.
11. Turn off furnace power supply.
12. Remove manometer.
13. Apply pipe dope sparingly to the 1/8–in. (3 mm) NPT pipe plug and install in the 1/8–in. (3 mm) tapped inlet–pressure tap opening in the gas valve. DO NOT over–tighten. Check for gas leaks after gas supply has been turned on.

## CHECK FURNACE AND MAKE ADJUSTMENTS

1. Be sure main gas and electric supplies to furnace are off.
2. Remove 1/8–in. (3 mm) NPT pipe plug from manifold pressure tap on downstream side of gas valve.
3. Attach manometer to manifold pressure tap on gas valve. (See Figure 28)

# ⚠ WARNING

## FIRE AND EXPLOSION HAZARD

Failure to follow this warning could result in personal injury and/or death.

NEVER test for gas leaks with an open flame. Use a commercially available soap solution made specifically for the detection of leaks to check all connections. A fire or explosion may result causing property damage, personal injury or loss of life.

# ⚠ AVERTISSEMENT

## RISQUE D'EXPLOSION ET D'INCENDIE

Le fait de ne pas suivre cet avertissement pourrait entraîner des dommages corporels et / ou la mort.

Ne jamais examiner pour les fuites de gaz avec une flamme vive. Utilisez plutôt un savon fait spécifiquement pour la détection des fuites de gaz pour vérifier tous les connexions. Un incendie ou une explosion peut entraîner des dommages matériels, des blessures ou la mort.

# ⚠ WARNING

## FIRE, EXPLOSION, ELECTRICAL SHOCK HAZARD

Failure to follow this warning could result in personal injury, death or property damage.

Gas supply **MUST** be shut off before disconnecting electrical power and proceeding with conversion.

# ⚠ WARNING

## ELECTRICAL SHOCK, FIRE OR EXPLOSION HAZARD

Failure to follow this warning could result in personal injury, death or property damage.

Before installing, modifying, or servicing system, main electrical disconnect switch must be in the OFF position and install a lockout tag. There may be more than one disconnect switch. Lock out and tag switch with a suitable warning label. Verify proper operation after servicing.

4. Turn gas supply manual shutoff valve to ON position.
5. Turn furnace gas valve switch to ON position.
6. Check all threaded pipe connections for gas leaks.
7. Turn on furnace power supply.

## GAS INPUT RATE INFORMATION

See furnace rating plate on blower door for input rate. The input rate for natural gas is determined by manifold pressure and orifice size.

Determine natural gas orifice size and manifold pressures for correct input at installed altitude by using **Table 7** and **Table 8**.

1. Obtain yearly heat–value average (at installed altitude) for local gas supply.
2. Obtain yearly specific–gravity average for local gas supply.
3. Find installation altitude in **Table 7** and **Table 8**.

**NOTE:** For Canada altitudes of 2000 to 4500 ft., use U.S.A. Altitudes of 2001 to 3000 ft. In **Table 7** and **Table 8**.

4. Find closest natural gas heat value and specific gravity in **Table 7** and **Table 8**.
5. Follow heat–value line and specific–gravity line to point of intersection to find orifice size and high– and low–heat manifold pressure settings.

Furnace gas input rate on rating plate is for installations at altitudes up to 2000 ft. (610 M).

**In the U.S.A.,** the input rating for altitudes above 2000 ft. (610M) must be reduced by 4 percent for each 1000 ft. (305 M) above sea level.

**In Canada,** the input rating must be derated by 10 percent for altitudes of 2000 ft. (610 M) to 4500 ft. (1372 M) above sea level.

The Conversion Kit Rating Plate accounts for high altitude derate.

## SET GAS INPUT RATE

1. Make sure the gas supply is turned off to the furnace and at the electric switch on the gas valve.
2. Remove the 1/8-in. (3 mm) NPT plug from the outlet pressure tap on the gas valve.
3. Connect a manometer to the outlet pressure tap on gas valve.
4. Turn on furnace power supply.
5. Turn gas supply manual shutoff valve to ON position.
6. Turn furnace gas valve switch to ON position.
7. Verify SW1-2 on furnace control is turned "ON".
8. Jumper R and W/W1 thermostat connections to call for heat.
9. Check manifold orifices for gas leaks when main burners ignite.
10. Adjust gas manifold pressure. Refer to **Table 7** and **Table 8**.
11. Remove caps that conceal the adjustment screws for gas valve regulators. (See **Figure 28**)
12. Adjust low-heat manifold pressure for natural gas. (See **Figure 28**)
13. Turn low-heat adjusting screw counterclockwise (out) to decrease input rate or clockwise (in) to increase input rate.

**NOTE:** When correct input is obtained, main burner flame should be clear blue, almost transparent (See **Figure 31**)

14. Jumper R, W/W1 and W2 on control center thermostat connections. This keeps furnace locked in high-heat operation.
15. Adjust high-heat manifold pressure for natural gas.
16. Turn high-heat adjusting screw counterclockwise (out) to decrease input rate or clockwise (in) to increase input rate.
17. Replace caps that conceal the gas valve regulator adjustment screws.

**NOTE:** When correct input is obtained, main burner flame should be clear blue, almost transparent (See **Figure 31**)

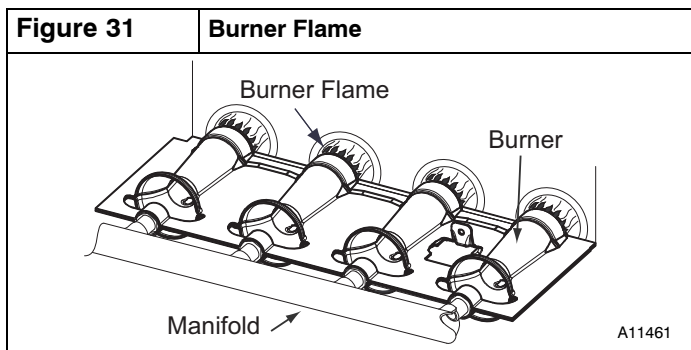

18. Remove jumper across R, W1, and W2 after high-heat adjustment to terminate call for heat.
19. Turn setup switch SW1-2 on furnace control to OFF position.
20. Turn furnace gas valve switch to OFF position.
21. Turn off furnace power supply.
22. Remove manometer and reinstall manifold pressure tap plug.
23. Turn furnace gas valve switch to ON position.
24. Turn on furnace power supply.
25. Set room thermostat to call for heat.
26. Check pressure tap plug for gas leaks when main burners ignite.
27. Check for correct burner flame.
28. After making the required manifold pressure adjustments, check and adjust the furnace temperature rise per the furnace installation instructions.

## LABEL APPLICATION

1. Fill in Conversion Responsibility Label 340741-205 and apply over the Propane Conversion label. (See **Figure 15**) Date, name, and address of organization making this conversion are required.
2. Apply Conversion Rating Plate Label 340741-204 over the Propane Conversion label on outer door of furnace. (See **Figure 32**)
3. Apply Gas Control Conversion Label: For 2-stage J and G gas valves, use Gas Control Conversion Label 340741-202. (DO NOT use 340741-203, which is similar.) For 2-stage E gas valve, use Gas Control Adjustment Label 340741-203. (DO NOT use 340741-202, which is similar.)

## CHECKOUT

1. Observe unit operation through two complete heating cycles.
2. See Sequence of Operation operation in furnace Installation, Start-Up, and Operating Instructions.
3. Set room thermostat to desired temperature.

Figure 31		Burner Flame	
Figure 32		Conversion Kit Rating Plate	
<b>CONVERSION KIT RATING PLATE - CARRIER CORPORATION</b> THIS APPLIANCE HAS BEEN CONVERTED TO USE NATURAL GAS FOR FUEL. REFER TO KIT INSTRUCTIONS FOR CONVERSION PROCEDURES. USE PARTS SUPPLIED BY CARRIER CORPORATION AND INSTALLED BY QUALIFIED PERSONNEL. SEE EXISTING RATING PLATE FOR APPLIANCE MODEL NO. AND INPUT RATING. NOTE: Furnace gas input rate on rating plate is for installations up to 2000 ft. (610m) above sea level. In U.S.A. the input rating for altitudes above 2000 ft. (610m) must be derated by 4% for each 1000 ft. (305m) above sea level. In Canada the input rating must be derated (per chart below) for altitudes of 2000 ft. (610m) to 4500 ft. (1372m) above sea level. (SUPERSEDES: KGAPN3501ALL, KGAPN3401ALL, KGAPN1601ALL, KGAPN21012SP, KGAPN2201ALL, KGAPN3301ALL, KGAPN3901ALL, KGAPN4401VSP, KGBPN4401VSP)			
KIT NO.: KGCPN4401VSP		FUEL USED: NATURAL GAS	
APPLIANCE MODELS	USA % DERATE PER 1000 FT.	CANADA % DERATE FOR 2000-4500 FT.	NATURAL GAS PRESSURE
	4%	10%	IN. W.C. (PO C.E.)
58CVA, 58CVX, 58CTW, 58CTY, 315AAV, 315JAV, 314AAV, 314JAV, PG8MV, PG8JV			PA
			High Heat 3.2 - 3.8 797 - 946
			Low Heat 1.4 - 1.8 349 - 448
			Refer to Installation Manual Respeter les Instruction D'Installation
			ALTIMUDE
			0-2,000 ft. (0 - 610 m)
			2,000 - 10,000 ft. (610 - 3050 m)
			Manifold Pressure
			Pression Tubulure
			(For Purpose of Input Adjustment) (Pour L'Adjustment D'Entree)

340741-204 REV.A