

6720810590-00.2W6

WARNING:
 Improper installation, set-up, modification, operation or maintenance of the heating system can cause personal injury and property damage.
 Follow these instructions precisely.
 If you require assistance or further information, contact a trained and certified installer or the gas supply company.

WARNING:
 The operating instructions are part of the technical documents that must be handed over to the owner or operator of the heating system.
 Explain to the owner or operator how to use the heating system using the operating instructions. Make sure that they are familiar with all required information for the safe and proper operation of the heating system.

NOTICE:
 These instructions are available in English and French.

Please keep these instructions for future reference.

Warranty information available at www.bosch-climate.us

Annual service is required

Residential Gas Condensing Boiler

Greenstar FS/Combi FS

KBR16-3A | KBR21-3A | KBR28-3A | KBR35-3A | KBR42-3A | KWB28-3A | KWB35-3A | KWB42-3A



BOSCH

Installation and Service Instructions for Contractors

6720810590 (2017/02) CA/US



Table of Contents

1	Key to symbols and safety instructions	3
1.1	Key to symbols	3
1.2	General safety instructions	4
2	Scope of delivery	5
2.1	KBR - Residential boiler for space heating and loading of indirect fired DHW tanks	5
2.2	KWB - Residential combi boiler for space heating and DHW generation	5
3	Information about the appliance	6
3.1	Proper use	6
3.2	Overview of boiler types	6
3.3	Rating plate	6
3.4	Appliance description	6
3.5	Accessories	6
3.6	Product dimensions and minimum clearances	7
3.7	Appliance layout heating boiler KBR..-3A	8
3.8	Appliance layout combi boiler KWB..-3A	10
3.9	Electrical wiring heating boiler KBR..-3A	12
3.10	Electrical wiring combi boiler KWB..-3A	14
3.11	Technical data heating boiler KBR 16-3	16
3.12	Technical data heating boiler KBR 21 -3	17
3.13	Technical data heating boiler KBR 28-3	18
3.14	Technical data heating boiler KBR 35-3	19
3.15	Technical data heating boiler KBR 42-3	20
3.16	Technical data combi boiler KWB 28-3	21
3.17	Technical data combi boiler KWB 35 - 3	22
3.18	Technical data combi boiler KWB 42 - 3	23
3.19	Condensate composition	24
4	Regulations	24
4.1	Compliance with standards and regulations	24
4.2	Operating limits of the boiler	24
4.3	Additional regulations for installation in Massachusetts	25
5	Common Applications of KBR boilers	26
5.1	Multiple zones using zone valves with DHW	26
5.1.1	To utilize the LLH	26
5.1.2	Wiring - Multi zone with zone valves and LWCO	27
5.2	Multiple zones using circulators with DHW	28
5.2.1	To utilize the LLH	28
5.2.2	Wiring	29
6	Installation	30
6.1	Installation and operation	30
6.1.1	Notes on installation and operation	30
6.1.2	Other important information	31
6.2	Comparing the size of the integrated expansion vessel (KWB-3A boiler only)	31
6.3	KBR..-3A appliances (heating boilers): Selecting an expansion vessel	32
6.4	Selecting the installation location	32
6.5	Low Loss Header (LLH) utilization	32
6.5.1	To utilize the LLH	32
6.6	Locating the appliance	33
6.6.1	Positioning the appliance	33
6.7	Installing a low water cut off (LWCO)	33
6.8	Connecting flue gas accessories	34
6.8.1	Installation of the exhaust and air intake system	36
6.8.2	Approved examples of horizontal and vertical venting installation	40
6.8.3	Vent and combustion air pipe lengths	42
6.9	Testing gas and water connections for leaks	43
7	Making the electrical connections	44
7.1	General notes	44
7.2	Electrical connections in the junction boxes	44
7.2.1	Access to junction boxes	44
7.2.2	Connecting the BUS-system	44
7.2.3	High voltage junction box	44
7.2.4	Connecting an external heating zone pump or DHW recirculation pump	45
7.2.5	DHW tank loading pump or 3-way valve with spring return (only heating boiler KBR..-3A)	45
7.2.6	Connecting mains power supply	46
7.2.7	Low voltage (LV) junction box	46
7.3	DHW tank temperature sensor connection	47
7.4	Connecting the LWCO device	47
8	Commissioning	48
8.1	Before operating the appliance	48
8.2	Switching the appliance ON/OFF	48
8.3	Setting up space heating	49
8.4	Programming the Bosch Room Controller	49
8.5	After commissioning	49
8.6	KBR..-3A appliances (heating boilers) with DHW tank: Setting the DHW temperature	50
8.7	KWB..-3A appliances (combi boilers): Setting the DHW temperature	50
8.8	Setting manual summer mode	50
8.9	Setting frost protection	51
8.10	Activating the key pad lock	51
9	KBR..-3A appliances (heating boiler) with DHW tank: Thermal disinfection	51
10	Boiler circulator	52
10.1	Pump anti-seize protection	52
10.2	Changing the pump curve of the boiler pump	52

11	Heatronic boiler control settings	53
11.1	Guideline to service functions	53
11.2	Overview of the service functions	53
11.2.1	First service level (press and hold the service button until it lights up)	53
11.2.2	Second service level (at first service level, service button lights up, press ECO button and key pad lock button simultaneously until 8.A appears)	54
11.3	Description of the service functions	54
11.3.1	First service level	54
11.3.2	Second service level	57
12	Gas type conversion	59
12.1	Installation location higher than 2,000 feet (610 m) above sea level	60
12.2	Setting the gas-air ratio (CO ₂ or O ₂)	60
12.3	Dynamic gas pressure test	61
13	Flue gas test	61
13.1	Emissions test button	61
13.2	Measuring CO content of flue gas	61
14	Environmental responsibility/disposal	62
15	Inspection and maintenance	62
15.1	Description of various steps	62
15.1.1	Calling up the latest fault (service function 6.A)	62
15.1.2	Fresh water filter (only combi boiler KWB..-3A)	63
15.1.3	Plate type heat exchanger (only combi boiler KWB..-3A) ..	63
15.1.4	Checking the electrodes	64
15.1.5	Burner servicing	64
15.1.6	Heat exchanger block inspection and cleaning	65
15.1.7	Condensate trap cleaning	66
15.1.8	Checking the mixer diaphragm	67
15.1.9	Expansion vessel	67
15.1.10	Setting the boiler water pressure	67
15.1.11	Testing system water quality	67
15.1.12	Inspecting electrical wiring	67
15.2	Checklist for annual inspection and maintenance	68
16	Readings on the display	69
17	Faults	70
17.1	Troubleshooting	70
17.2	Faults that are shown on the display	71
17.3	Faults that are not shown on the display	73
17.4	Check sensor values	74
17.4.1	Outdoor temperature sensor	74
17.4.2	Additional supply temperature limiter	74

17.4.3	Supply temperature sensor, External supply temperature sensor, DHW tank temperature sensor, DHW temperature sensor	74
17.5	Replacement code plug	74

18	Commissioning log for the appliance	75
-----------	--	-----------

19	Spare parts	77
-----------	--------------------------	-----------

1 Key to symbols and safety instructions

1.1 Key to symbols

Warnings



Warnings in this document are identified by a warning triangle printed against a grey background. Keywords at the start of a warning indicate the type and seriousness of the ensuing risk if measures to prevent the risk are not taken.

Keywords at the start of a warning indicate the type and seriousness of the ensuing risk if measures to prevent the risk are not taken. The following keywords are defined and can be used in this document:

- **DANGER** indicates a hazardous situation which, if not avoided, will result in death or serious injury.
- **WARNING** indicates a hazardous situation which, if not avoided, could result in death or serious injury.
- **CAUTION** indicates a hazardous situation which, if not avoided, could result in minor to moderate injury.

NOTICE: Contains no warning triangle and indicates a situation that could result in damage to property or equipment, but no personal injury.

Important information



This symbol indicates important information where there is no risk to people or property. Important information for the proper use of the boiler is also provided in this manual. You will find the information with a symbol shown on the left and bordered by horizontal lines above and below the text.

Additional symbols

Symbol	Explanation
▶	Sequence of steps
→	Cross-reference to other points in this document or to other documents
•	Listing/list entry
–	Listing/list entry (2nd level)

1.2 General safety instructions

If you hear gas leaking

- ▶ Leave the building immediately.
- ▶ Prevent others from entering the building.
- ▶ Notify the police and fire department from outside the building.
- ▶ From outside the building, call the gas supply company and a trained and certified installer or service company.

If you smell gas

- ▶ Turn off the gas shut-off valve.
- ▶ Open windows and doors
- ▶ Do not touch any electrical switch, telephone, and do not use outlets.
- ▶ Extinguish all open flames.
- ▶ Do not smoke!
- ▶ Do not use lighters!
- ▶ Warn all occupants of the building that they need to leave the building.
- ▶ Do not ring doorbells!
- ▶ Notify the police and fire department from outside the building.
- ▶ From outside the building, call the gas supply company and a trained and certified installer or service company.

If you smell flue gas

- ▶ Switch off the heating system by shutting off the emergency shut-off switch.
- ▶ Open windows and doors.
- ▶ Call a trained and certified installer or service company.

DANGER: Risk of fatal injury from failing to consider your own safety!

- ▶ Never risk your own life. Your own safety must always take the highest priority

NOTICE: Risk of appliance damage from improper operation of the boiler!

- ▶ Only use the boiler for its intended purpose.
- ▶ Only operate the boiler if it has been installed and maintained per the instructions provided in the Installation Manual.
- ▶ Do not attempt to operate an appliance if any part of it is not in working order or is damaged.
- ▶ Use only original spare parts! The use of parts not supplied by the manufacturer may cause damage to the boiler, other property and personal injury. Also, boiler damage caused by the use of unauthorized parts is not covered by the warranty.

DANGER: Risk of fire when soldering and brazing!

- ▶ Take appropriate protective measures when soldering and brazing around combustible and flammable material.

NOTICE:

- ▶ The installation must comply with all applicable national, state, and local codes, rules, and regulations.
- ▶ The operator is responsible for the operational safety and regulatory compliance of the heating system.

DANGER: Risk of personal injury or death from flue gas poisoning!

- ▶ Do not install a thermostatic flue gas damper downstream of the draft hood.
- ▶ Do not tamper with, remove, or attempt to repair the blocked vent switch.
- ▶ When replacing the blocked vent switch, install the new part in the original location.
- ▶ A blocked vent switch tripping more than once indicates a problem with the venting system or chimney which must be repaired immediately.
- ▶ Ensure none of the vent pipes and chimneys are damaged or blocked.

- ▶ Connect only one appliance to each venting system or chimney.
- ▶ The venting system must not feed into or route through another air extraction duct.
- ▶ The venting system must be inspected annually. All parts that show any signs of damage or corrosion must be replaced.
- ▶ Never close off or reduce the size of the combustion air openings.
- ▶ The boiler must not be operated until any obstructions have been removed.

DANGER: Risk of personal injury or death from explosion!

- ▶ Work on gas components may only be carried out by a trained and certified installer or service company.
- ▶ Appliance installation, the connection of gas and vent piping, initial commissioning, electrical connections, and service and maintenance must only be carried out by a trained and certified installer or service company.

DANGER: Risk of personal injury or death from fire!

- ▶ Do not use flammable or combustible material in the boiler room.
- ▶ It is recommended not to store any items within 16 inches (415mm) of the appliance

CAUTION: Appliance damage from contaminated combustion air!

- ▶ Keep the combustion air free of corrosive substances, e.g. halogenated hydrocarbons from painting operations or beauty salons.
- ▶ Keep combustion air free from dust and lint, e.g. from laundry or agricultural operations.
- ▶ If clean room air is not available, fresh outdoor combustion air must be provided

DANGER: Risk of personal injury or death from electric shock.

- ▶ Before removing the front panel, disconnect the heating system from the electrical power supply by shutting off the emergency shutoff switch or the heating system circuit breaker.
- ▶ It is not enough to switch off the control panel. **Power to the panel must be disconnected!** Ensure that the power is not restored unintentionally by following proper lock out/tag out procedures.
- ▶ Only qualified electricians are permitted to carry out electrical work.

DANGER: Safety devices!

- ▶ Never shut off safety valves!
- ▶ Hot water may escape from the safety valve at any time when the appliance is running.

DANGER: Risk of personal injury or death after a flood!

- ▶ Do not attempt to operate an appliance if any part of it has been under water.
- ▶ An appliance that was subject to flooding must be replaced.

NOTICE:

- ▶ Upon completion of the installation, these instructions should be handed to the owner and operator of the appliance.
- ▶ The installer must instruct the owner and operator on the functionality of the components and the proper operation of the boiler and the heating system.
- ▶ The boiler must be serviced annually including the main burner, ignition burner, the entire venting system, and the combustion air supply. All parts that show any signs of damage or corrosion must be replaced.

2 Scope of delivery

2.1 KBR - Residential boiler for space heating and loading of indirect fired DHW tanks

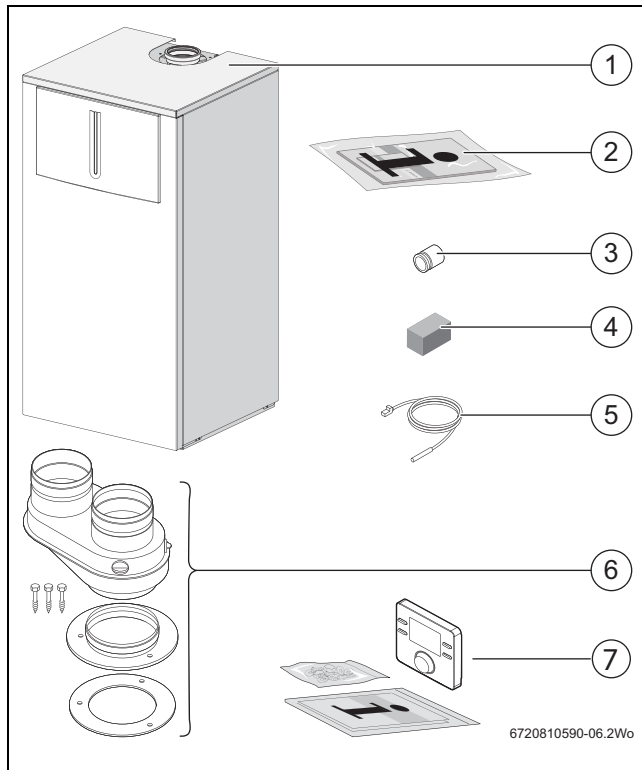

Fig. 1 Scope of delivery heating boiler KBR...-3A

Contents of package 1:

- [1] Gas condensing boiler
- [2] Set of documents for appliance
- [3] Adapter for connection of a LWCO
- [4] Gas conversion kit
- [5] DHW tank temperature sensor (NTC)
- [6] Flue adapter¹⁾
- [7] Bosch Room Controller with an integrated temperature sensor and set of documents

1) Concentric vent kit available as accessory.

2.2 KWB - Residential combi boiler for space heating and DHW generation

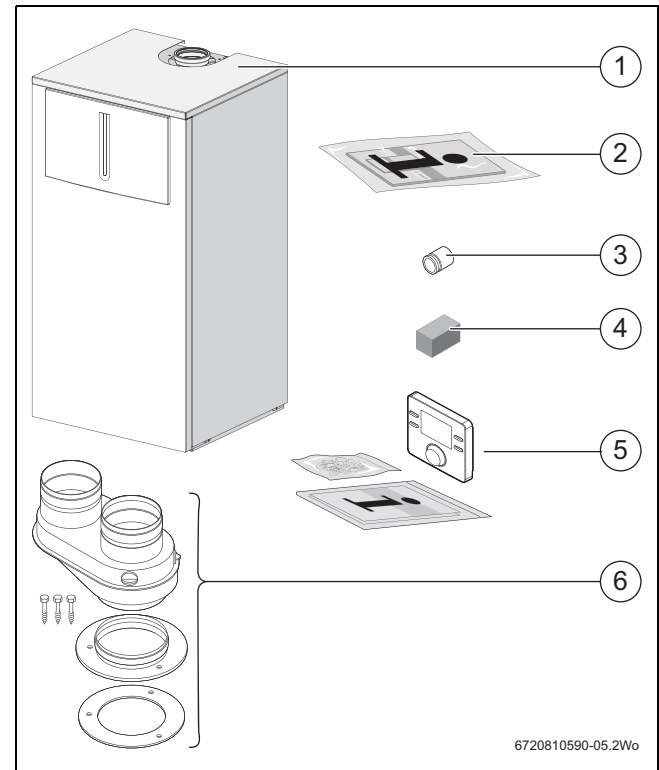

Fig. 2 Scope of delivery combi boiler KWB...-3A

Contents of package 1:

- [1] Gas condensing boiler
- [2] Set of documents for appliance
- [3] Adapter for connection of a LWCO
- [4] Gas conversion kit
- [5] Bosch Room Controller with an integrated temperature sensor and set of documents
- [6] Flue adapter²⁾

2) Concentric vent kit available as accessory.

3 Information about the appliance

KBR appliances are natural gas, residential boilers for central heating and loading of an indirect fired DHW tank.

KWB appliances are natural gas, residential combi boilers for central heating and on demand DHW heating.

The appliances comply with South Coast Air Quality Management District (SCAQMD) 2012 requirements: (Type-1) 14 Ng/J NO_x (and/or 20 ppm at 3% O₂).

3.1 Proper use

The appliance may only be installed in closed loop hot water central heating systems.

Any other purpose is considered improper use. Any resulting damage is excluded from the manufacturer's warranty.

The commercial and industrial use of the appliance for generating process heat is not permitted.

3.2 Overview of boiler types

Table 1 describes the meaning of the model number:

KBR16-3	Heat only appliance	A	23
KBR21-3	Heat only appliance	A	23
KBR28-3	Heat only appliance	A	23
KBR35-3	Heat only appliance	A	23
KBR42-3	Heat only appliance	A	23
KWB28-3	Combi appliance	A	23
KWB35-3	Combi appliance	A	23
KWB42-3	Combi appliance	A	23

Table 1 Appliance types

K	Floor standing heating appliance
W	DHW heating
B	Condensing technology
R	Constant temperature control
16...42	Reference to output in kW. 42kW output equals 143 310BTU/hr
-3	Version
A	Fan-supported appliance
23	Natural gas (NG)

3.3 Rating plate

The rating plate is located at the right side of the appliance.

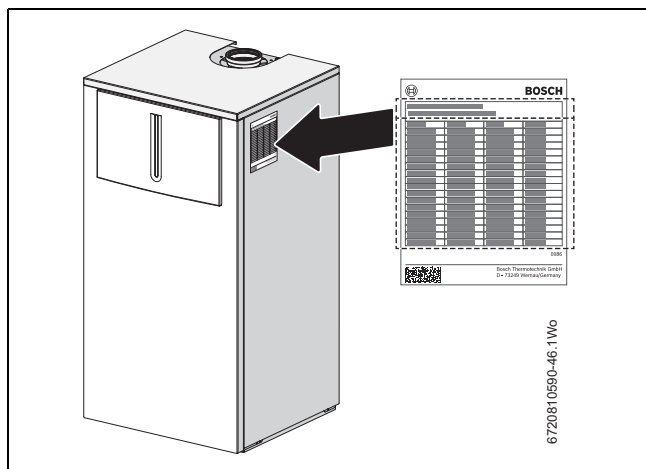

Fig. 3 Position of the rating plate

The rating plate contains the appliance output, model number, approval data and serial number.

3.4 Appliance description

- Appliance is a floor mounted installation
- Intelligent boiler pump control
- Heatronic boiler control
- Three-speed boiler circulator
- Automatic air vent (combi boiler only)
- Display
- Automatic ignition
- Continuously-controlled output
- Full protection via the Heatronic with flame rod and solenoid valves
- No minimum circulating water flow rate required
- Suitable for all hydronic emitters
- Flue adapter for flue gas and combustion air with test ports
- Variable speed fan
- Gas premix burner
- Heat exchanger temperature and high limit sensor
- LLH / Supply temperature sensor
- Temperature limiter
- Safety relief valve, pressure gauge
- Expansion vessel (combi boiler only)
- Connection possibility for DHW tank temperature sensor (NTC) (heating boiler only)
- Flue gas temperature limiter
- Connection for DHW...
- DHW (combi boiler only)
- Internal motorized 3-way valve (combi boiler only)
- Integrated low loss header with option to isolate flow

3.5 Accessories



Here you will find a list of typical accessories for this appliance. Refer to the Bosch Product Catalog for a complete overview of all available accessories.

- Weather compensation control FW200
- CRC100 or CRC200 user interfaces
- CZM100 Zoning module
- Optional concentric vent kit available for horizontal direct vent terminations
- Modules for system expansions:
 - ICM for cascading up to 4 boilers

3.6 Product dimensions and minimum clearances

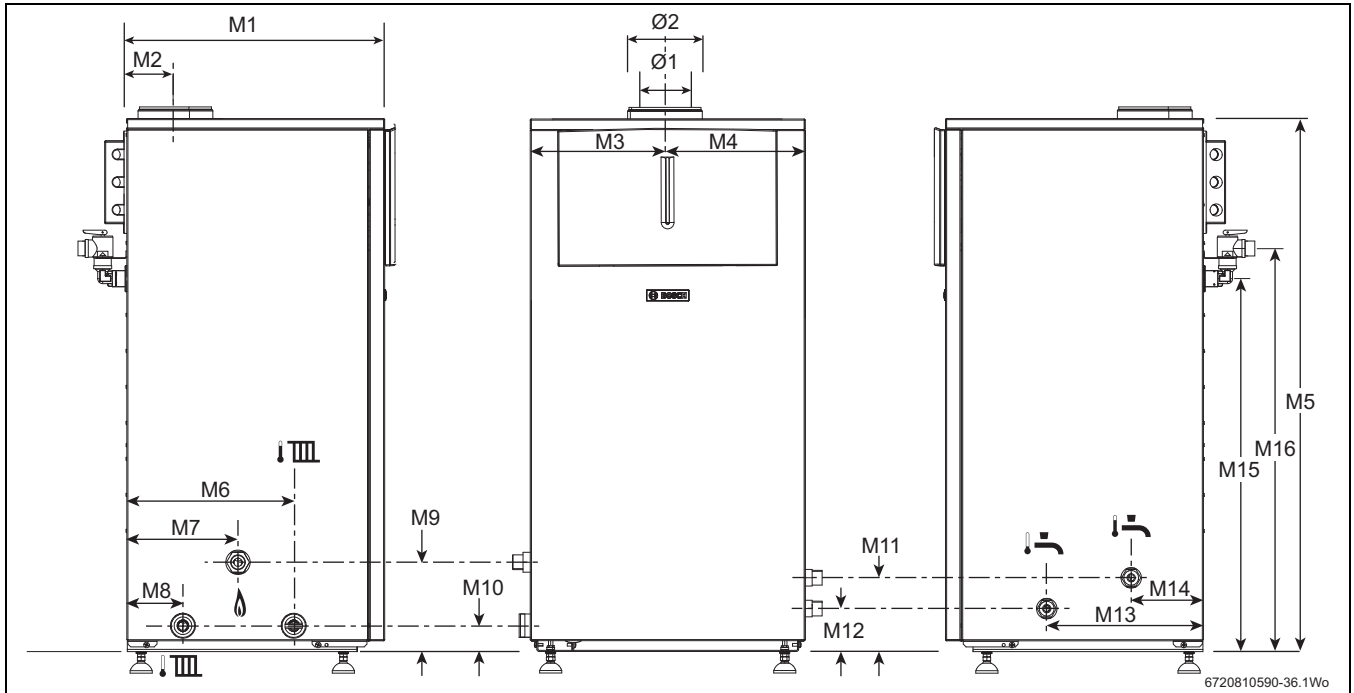

Fig. 4

- [M1] 18 ³/₈" - (467mm)
- [M2] 3 ¹/₂" - (88mm)
- [M3] 9 ⁵/₈" - (243.5mm)
- [M4] 10" - (253.5mm)
- [M5] 39 ¹/₂" - (1003mm)
- [M6] 11 ⁷/₈" - (301.5mm)
- [M7] 7 ⁷/₈" - (200mm)
- [M8] 4" - (101mm)
- [M9] 8 ³/₁₆" - (207.3mm)
- [M10] 3 ⁷/₁₆" - (86.7mm)
- [M11] 6 ¹³/₁₆" - (173.3mm)
- [M12] 4 ⁵/₈" - (117.6mm)
- [M13] 11 ³/₁₆" - (283mm)
- [M14] 5 ¹/₈" - (131mm)
- [M15] 28 ¹/₁₆" - (713.5mm)
- [M16] 31" - (788mm)
- [Ø 1] 3 ¹/₈" - (80mm)
- [Ø 2] 4 ¹⁵/₁₆" - (125mm)

Symbol	Description	Connection size
	Domestic water inlet	¾" - (19mm)
	Domestic hot water outlet	¾" - (19mm)
	Heating return	1¼" - (31.8mm)
	Heating supply	1¼" - (31.8mm)
	Gas inlet	¾" - (19mm)

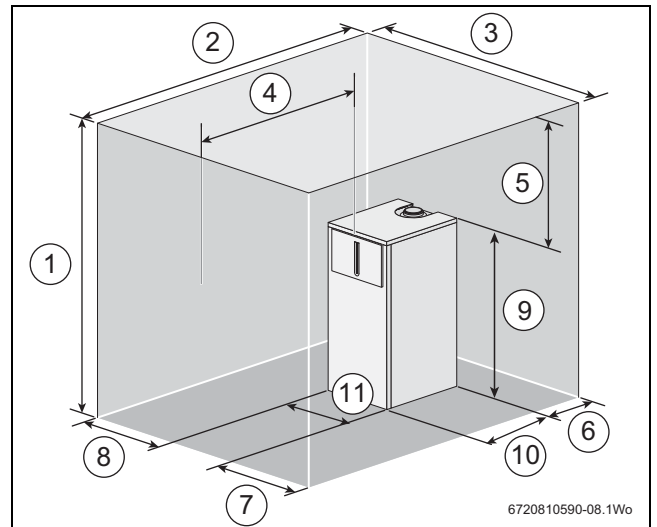
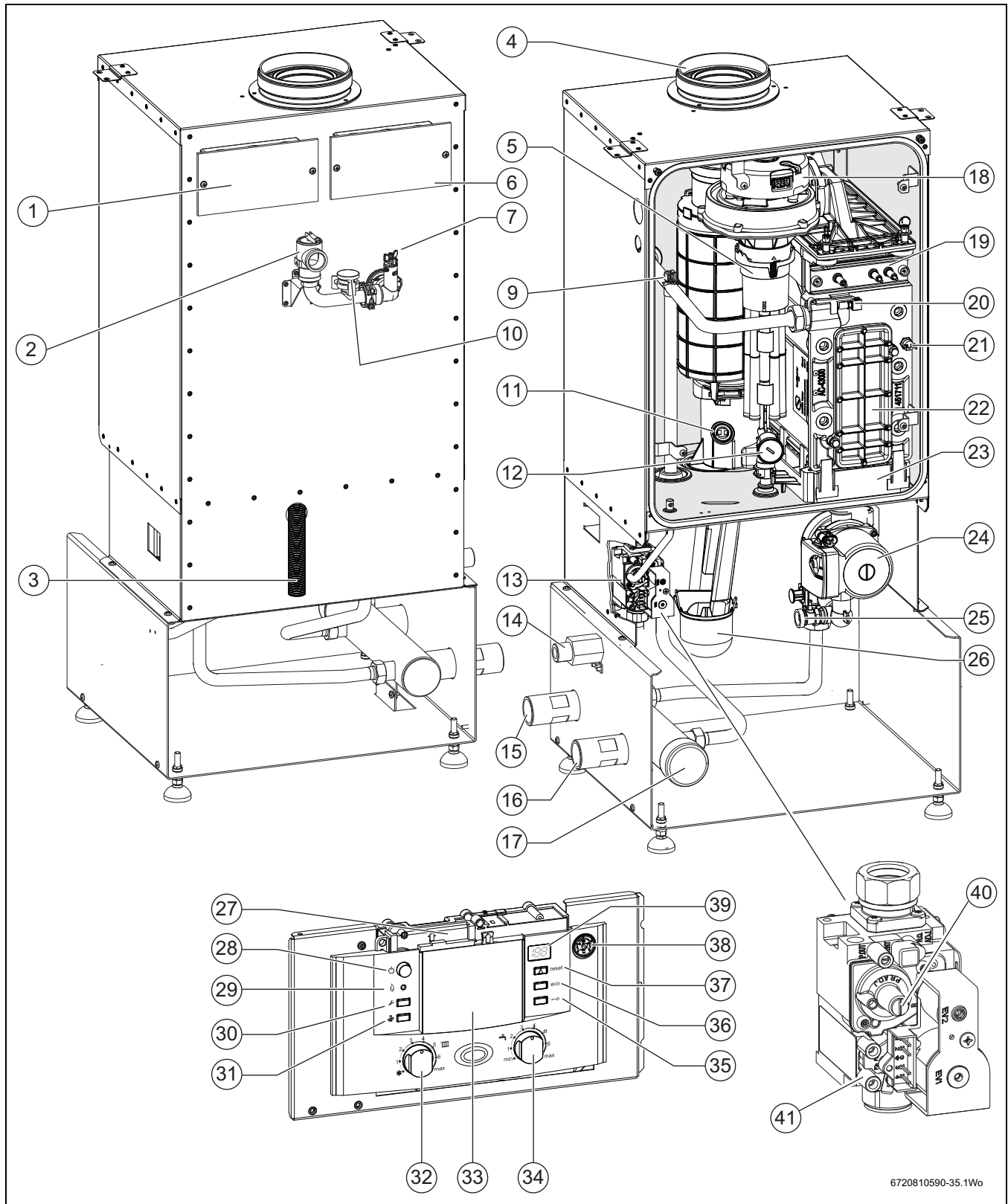

Fig. 5 Dimensions and minimum clearances (front, rear, & side view)

- [1] 45 ³/₄" - (1163mm)
 - [2] 41 ¹⁵/₁₆" - (1065mm)
 - [3] 27 ⁹/₁₆" - (700mm)
 - [4] **24" - (600mm)
 - [5] 7 ⁷/₈" - (200mm)
 - [6] *** ≥ 2 ³/₄" - (70mm)
 - [7] *4" - (102mm)
 - [8] *4" - (102mm)
 - [9] 41" - (1042mm)
 - [10] 18 ³/₈" - (467mm)
 - [11] 19 ⁹/₁₆" - (497mm)
- (*) Zero clearance from combustibles permitted, but 4" (102 mm) recommended for serviceability
 (**) 1" (25mm) Distance to door, if mounted inside a closet with 24" (600mm) in front of boiler for serviceability
 (***) 12" (300mm) recommended distance behind the boiler for serviceability

3.7 Appliance layout heating boiler KBR...-3A



6720810590-35.1Wo

Fig. 6 Appliance layout heating boiler KBR...-3A

Key to Fig. 6 Heating boiler KBR..-3A:

- [1] Pre-wired low voltage installer connection box
- [2] Pressure Relief Valve (PRV)
- [3] Condensate hose
- [4] Flue connector for twin pipe adaptor
- [5] Air/gas premix chamber
- [6] Pre-wired high voltage installer connection box
- [7] Manual air bleed
- [9] Additional supply temperature limiter
- [10] Connection of optional Low Water Cut Off (LWCO)
- [11] Flue gas temperature limiter
- [12] Cover for maximum gas adjuster
- [13] Gas valve
- [14] Gas connection
- [15] Heating return connection
- [16] Heating supply connection
- [17] Low Loss Header with flow sensor
- [18] Fan
- [19] Electrode set
- [20] Primary heat sensor
- [21] Maximum safety sensor
- [22] Inspection and clean out cover
- [23] Condensate collector
- [24] Boiler circulator
- [25] Drain cock
- [26] Condensate trap
- [27] Heatronic boiler control
- [28] ON/OFF switch
- [29] Burner on indicator
- [30] Service button
- [31] Emission test button
- [32] Boiler high limit dial
- [33] Mounting socket for outdoor reset control
- [34] DHW Setpoint Dial
- [35] Keypad lock button
- [36] ECO button
- [37] Reset button
- [38] Boiler water pressure gauge
- [39] Display
- [40] Gas valve minimum adjuster
- [41] Gas inlet pressure test point

3.8 Appliance layout combi boiler KWB...-3A

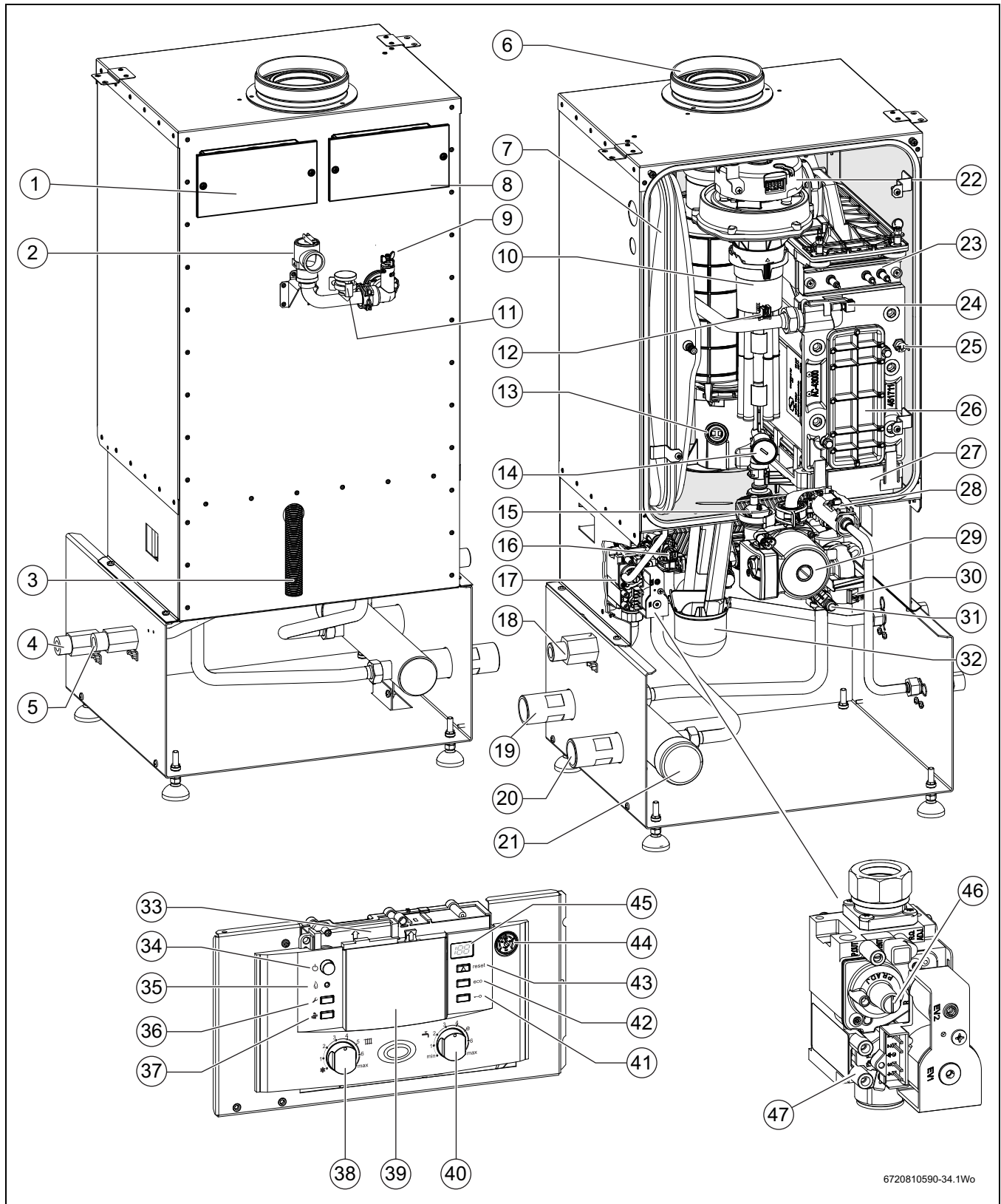

6720810590-34.1W0

Fig. 7 Appliance layout combi boiler KWB...-3A

Key to Fig. 7 Combi boiler KWB..-3A:

- [1] Pre-wired low voltage installer connection box
- [2] Pressure Relief Valve (PRV)
- [3] Condensate hose
- [4] DHW inlet
- [5] DHW outlet
- [6] Flue connector for twin pipe adaptor
- [7] Expansion vessel
- [8] Pre-wired high voltage installer connection box
- [9] Manual air bleed
- [10] Air/gas premix chamber
- [11] Connection for optional Low Water Cut Off (LWCO)
- [12] Additional supply temperature limiter
- [13] Flue gas temperature limiter
- [14] Cover for maximum gas adjuster
- [15] Air vent
- [16] DHW thermostat
- [17] Gas valve
- [18] Gas connection
- [19] Central heat return connection
- [20] Central heating supply connection
- [21] Low Loss Header and flow sensor
- [22] Fan
- [23] Electrode set
- [24] Primary heat sensor
- [25] Maximum safety sensor
- [26] Inspection and clean out cover
- [27] Condensate collector
- [28] Flow meter
- [29] Pump
- [30] Three way valve
- [31] Drain cock
- [32] Condensate trap
- [33] Heatronic boiler control
- [34] ON/OFF switch
- [35] Burner flame indicator
- [36] Service button
- [37] Emission test button
- [38] Boiler high limit dial
- [39] Mounting socket for outdoor reset control
- [40] DHW Setpoint Dial
- [41] Keypad lock button
- [42] ECO button
- [43] Reset button
- [44] Boiler water pressure gauge
- [45] Display
- [46] Gas valve minimum adjuster
- [47] Gas inlet pressure test point

3.9 Electrical wiring heating boiler KBR..-3A

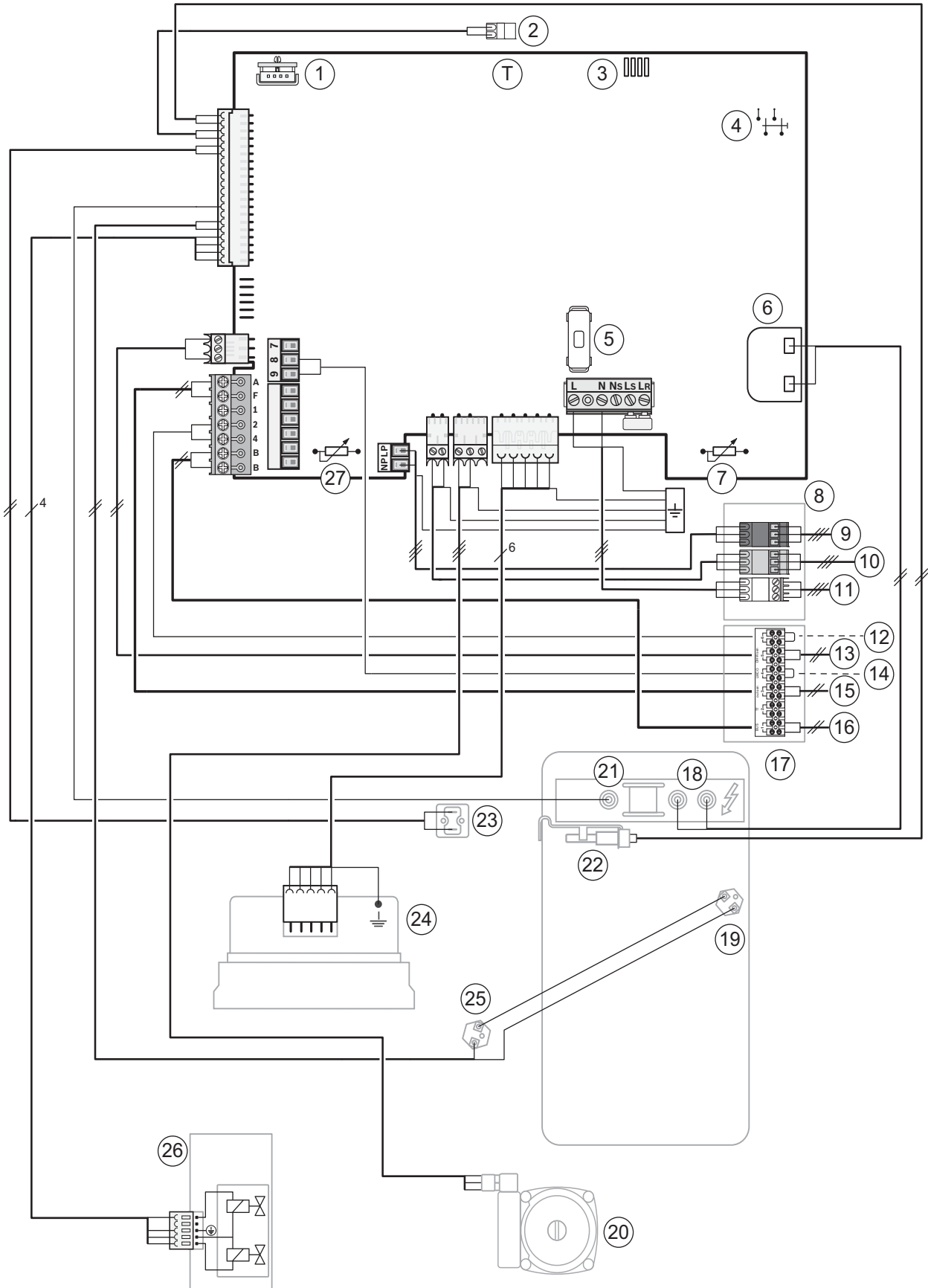

Fig. 8 Electrical wiring diagram heating boiler KBR..-3A

6720810590-10-1Wo

Key to Fig. 8 Heating boiler KBR..-3A:

- [T] Top of control board
- [1] Code plug
- [2] System supply temperature sensor
- [3] Diagnostic interface
- [4] ON/OFF switch
- [5] Fuse T 6.3 A (120 VAC)
- [6] Ignition transformer
- [7] Boiler high limit dial
- [8] High voltage - Installer connection box
- [9] External heating pump
- [10] DHW tank primary pump or 3 way valve
- [11] 120 VAC connection
- [12] Empty (future connectivity)
- [13] DHS Sen - Domestic Hot Water temperature sensor (NTC)
- [14] LWCO - Low Water Cut Off
- [15] Out Sen - Outdoor temperature sensor
- [16] BUS - BUS connection to programmer
- [17] Low voltage - Installer connection box
- [18] Ignition electrode
- [19] Boiler block temperature limiter
- [20] Boiler circulator
- [21] Flame rod electrode
- [22] LLH/Supply temperature sensor
- [23] Additional supply temperature limiter
- [24] Fan
- [25] Flue gas temperature limiter
- [26] Gas valve
- [27] DHW Setpoint Dial

3.10 Electrical wiring combi boiler KWB..-3A

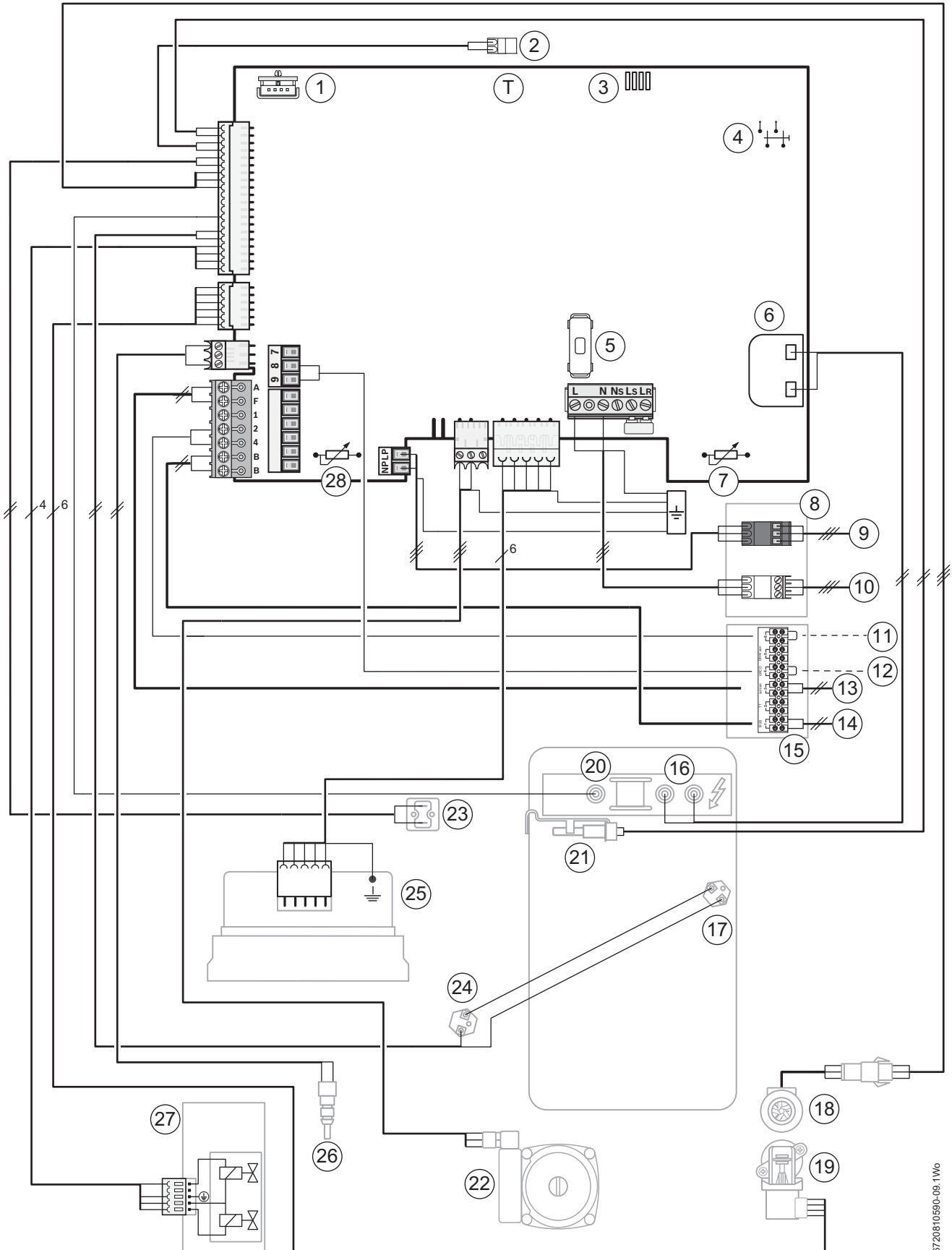

Fig. 9 Electrical wiring diagram combi boiler KWB..-3A

6720810590-09_1Wo

Key to Fig. 9 Combi boiler KWB..-3A:

- [T] Top of control board
- [1] Code plug
- [2] System supply temperature sensor
- [3] Diagnostic interface
- [4] ON/OFF switch
- [5] Fuse T 6.3 A (120 VAC)
- [6] Ignition transformer
- [7] Boiler high limit dial
- [8] High voltage - Installer connection box
- [9] External heating pump
- [10] 120 VAC connection
- [11] Empty (future connectivity)
- [12] LWCO - Low Water Cut Of
- [13] Out Sen - Outdoor temperature sensor
- [14] BUS - BUS connection to programmer
- [15] Low voltage - Installer connection box
- [16] Ignition electrode
- [17] Boiler block temperature limiter
- [18] Flow meter (turbine)
- [19] 3 way valve (space heating/DHW heating)
- [20] Flame rod electrode
- [21] LLH/Supply temperature sensor
- [22] Boiler circulator
- [23] Additional supply temperature limiter
- [24] Flue gas temperature limiter
- [25] Fan
- [26] DHW temperature sensor
- [27] Gas valve
- [28] DHW Setpoint Dial

3.11 Technical data heating boiler KBR 16-3

Input/Output	Unit	NG	LPG (Propane)
Max. input rate 180/79 °F (82/26 °C)	BTU/hr (kW)	57,200 (16.8)	56,400 (16.5)
Max. output rate 104/86 °F (40/30 °C)	BTU/hr (kW)	54,900 (16.1)	55,300 (16.2)
Max. output rate 122/86 °F (50/30 °C)	BTU/hr (kW)	54,300 (15.9)	54,600 (16.0)
Max. output rate 176/140 °F (80/60 °C)	BTU/hr (kW)	50,800 (14.9)	51,200 (15.0)
Min. input rate 180/79 (82/26 °C)	BTU/hr (kW)	12,900 (3.8)	21,500 (6.3)
Min. output rate 104/86 °F (40/30 °C)	BTU/hr (kW)	12,600 (3.7)	21,500 (6.3)
Min. output rate 122/86 °F (50/30 °C)	BTU/hr (kW)	12,600 (3.7)	21,500 (6.3)
Min. output rate 176/140 °F (80/60 °C)	BTU/hr (kW)	11,300 (3.3)	19,400 (5.7)
Gas connection value			
Natural gas - H ₅ = 1,010 BTU/ft ³ (37.3 MJ/m ³)	ft ³ /hr (m ³ /h)	56 (1.6)	-
Liquid Propane Gas - HD-S = 2,500 BTU/ft ³ (93.1 MJ/m ³)	ft ³ /hr (m ³ /h)	-	22 (0.6)
Permissible gas inlet pressure			
NG	in. W.C. (mbar)	3.5-10.5" (8.7-26.1)	-
LPG (Propane)	in. W.C. (mbar)	-	8-13" (19.9-32.3)
Flue gas			
Flue gas mass flow at maximum/minimum nominal output	gps	6.8/1.7	6.7/2.6
Flue gas temperature 176/140 °F (80/60 °C) at maximum/minimum nominal heat input	°F (°C)	136/133 (58/56)	136/133 (58/56)
Flue gas temperature 104/86 °F (40/30 °C) at maximum/minimum nominal heat input	°F (°C)	99/88 (37/31)	99/88 (37/31)
CO ₂ at maximum nominal output	%	9.4	11.0
CO ₂ at minimum nominal output	%	8.6	10.4
Condensate			
Maximum condensate quantity (t _R = 86 °F (30 °C))	gph (i/h)	0.32 (1.2)	0.32 (1.2)
pH level approx.		4.8	4.8
General			
Voltage	Vac	120	120
Frequency	Hz	60	60
Max. power consumption (central heating mode)	W	205	205
Max. power consumption (standby mode)	W	<6	<6
Sound pressure level	dB (A)	≤ 33	≤ 33
Max. supply temperature	°F (°C)	190 (88)	190 (88)
Max. permissible operating pressure (P _{MS}) heating	psi (bar)	30 (2.07)	30 (2.07)
Permissible ambient temperature	°F (°C)	32 - 122 (0 - 50)	32 - 122 (0 - 50)
Nominal water capacity (heating)	Gal (L)	0.925 (3.5)	0.925 (3.5)
Weight (without packaging)	lbs (kg)	132(60)	132(60)
Maximum overall dimensions W x H x D	inch (mm)	21 ¹⁵ / ₁₆ x 41 ¹ / ₄ x 21 ⁷ / ₈ 557 x 1048 x 555	21 ¹⁹ / ₁₆ x 41 ¹ / ₄ x 21 ⁷ / ₈ 557 x 1048 x 555

3.12 Technical data heating boiler KBR 21 -3

Input/Output	Unit	NG	LPG (Propane)
Max. input rate 180/79 °F (82/26 °C)	BTU/hr (kW)	79,200 (23.2)	77,500 (22.7)
Max. output rate 104/86 °F (40/30 °C)	BTU/hr (kW)	74,700 (21.9)	74,700 (21.9)
Max. output rate 122/86 °F (50/30 °C)	BTU/hr (kW)	74,000 (21.7)	74,000 (21.7)
Max. output rate 176/140 °F (80/60 °C)	BTU/hr (kW)	70,300 (20.6)	70,300 (20.6)
Min. input rate 180/79 (82/26 °C)	BTU/hr (kW)	24,600 (7.2)	40,100 (11.7)
Min. output rate 104/86 °F (40/30 °C)	BTU/hr (kW)	23,900 (7.0)	39,900 (11.7)
Min. output rate 122/86 °F (50/30 °C)	BTU/hr (kW)	23,900 (7.0)	39,600 (11.6)
Min. output rate 176/140 °F (80/60 °C)	BTU/hr (kW)	21,800 (8.4)	36,200 (10.6)
Gas connection value			
Natural gas - H ₅ = 1,010 BTU/ft ³ (37.3 MJ/m ³)	ft ³ /hr (m ³ /h)	78 (2.2)	-
Liquid Propane Gas - HD-S = 2,500 BTU/ft ³ (93.1 MJ/m ³)	ft ³ /hr (m ³ /h)	-	31 (0.9)
Permissible gas inlet pressure			
NG	in. W.C. (mbar)	3.5-10.5" (8.7-26.1)	-
LPG (Propane)	in. W.C. (mbar)	-	8-13" (19.9-32.3)
Flue gas			
Flue gas mass flow at maximum/minimum nominal output	gps	9.4/3.2	9.2/4.8
Flue gas temperature 176/140 °F (80/60 °C) at maximum/minimum nominal heat input	°F (°C)	145/133 (63/56)	145/133 (63/56)
Flue gas temperature 104/86 °F (40/30 °C) at maximum/minimum nominal heat input	°F (°C)	115/90 (46/32)	115/90 (46/32)
CO ₂ at maximum nominal output	%	9.4	11.0
CO ₂ at minimum nominal output	%	8.6	10.4
Condensate			
Maximum condensate quantity (t _R = 86 °F (30 °C))	gph (l/h)	0.32 (1.2)	0.32 (1.2)
pH level approx.		4.8	4.8
General			
Voltage	Vac	120	120
Frequency	Hz	60	60
Max. power consumption (central heating mode)	W	205	205
Max. power consumption (standby mode)	W	<6	<6
Sound pressure level	dB (A)	≤ 39	≤ 39
Max. supply temperature	°F (°C)	190 (88)	190 (88)
Max. permissible operating pressure (P _{MS}) heating	psi (bar)	30 (2.07)	30 (2.07)
Permissible ambient temperature	°F (°C)	32 - 122 (0 - 50)	32 - 122 (0 - 50)
Nominal water capacity (heating)	Gal (L)	0.925 (3.5)	0.925 (3.5)
Weight (without packaging)	lbs (kg)	132(60)	132(60)
Maximum overall dimensions W x H x D	inch (mm)	21 ¹⁵ / ₁₆ x 41 ¹ / ₄ x 21 ⁷ / ₈	21 ¹⁵ / ₁₆ x 41 ¹ / ₄ x 21 ⁷ / ₈
		557 x 1048 x 555	557 x 1048 x 555

3.13 Technical data heating boiler KBR 28-3

Input/Output	Unit	NG	LPG (Propane)
Max. input rate 180/79 °F (82/26 °C)	BTU/hr (kW)	100,000 (29.3)	98,600 (28.9)
Max. output rate 104/86 °F (40/30 °C)	BTU/hr (kW)	93,800 (27.5)	93,800 (27.5)
Max. output rate 122/86 °F (50/30 °C)	BTU/hr (kW)	93,100 (27.3)	93,100 (27.3)
Max. output rate 176/140 °F (80/60 °C)	BTU/hr (kW)	89,400 (26.2)	89,400 (26.2)
Min. input rate 180/79 (82/26 °C)	BTU/hr (kW)	24,600 (7.2)	40,100 (11.7)
Min. output rate 104/86 °F (40/30 °C)	BTU/hr (kW)	23,900 (7.0)	39,900 (11.7)
Min. output rate 122/86 °F (50/30 °C)	BTU/hr (kW)	23,900 (7.0)	39,600 (11.6)
Min. output rate 176/140 °F (80/60 °C)	BTU/hr (kW)	21,800 (6.4)	36,200 (10.6)
Gas connection value			
Natural gas - H ₂ = 1,010 BTU/ft ³ (37.3 MJ/m ³)	ft ³ /hr (m ³ /h)	99 (2.8)	-
Liquid Propane Gas - HD-S = 2,500 BTU/ft ³ (93.1 MJ/m ³)	ft ³ /hr (m ³ /h)	-	39 (1.1)
Permissible gas inlet pressure			
NG	in. W.C. (mbar)	3.5-10.5" (8.7-26.1)	-
LPG (Propane)	in. W.C. (mbar)	-	8-13" (19.9-32.3)
Flue gas			
Flue gas mass flow at maximum/minimum nominal output	gps	12.0/3.2	11.6/4.8
Flue gas temperature 176/140 °F (80/60 °C) at maximum/minimum nominal heat input	°F (°C)	147/133 (64/56)	147/133 (64/56)
Flue gas temperature 104/86 °F (40/30 °C) at maximum/minimum nominal heat input	°F (°C)	117/90 (47/32)	117/90 (47/32)
CO ₂ at maximum nominal output	%	9.4	11.0
CO ₂ at minimum nominal output	%	8.6	10.4
Condensate			
Maximum condensate quantity (t _R = 86 °F (30 °C))	gph (i/h)	0.32 (1.2)	0.32 (1.2)
pH level approx.		4.8	4.8
General			
Voltage	Vac	120	120
Frequency	Hz	60	60
Max. power consumption (central heating mode)	W	205	205
Max. power consumption (standby mode)	W	<6	<6
Sound pressure level	dB (A)	≤ 39	≤ 39
Max. supply temperature	°F (°C)	190 (88)	190 (88)
Max. permissible operating pressure (P _{MS}) heating	psi (bar)	30 (2.07)	30 (2.07)
Permissible ambient temperature	°F (°C)	32 - 122 (0 - 50)	32 - 122 (0 - 50)
Nominal water capacity (heating)	Gal (L)	0.925 (3.5)	0.925 (3.5)
Weight (without packaging)	lbs (kg)	132(60)	132(60)
Maximum overall dimensions W x H x D	inch (mm)	21 ¹⁵ / ₁₆ x 41 ¹ / ₄ x 21 ⁷ / ₈	21 ¹⁵ / ₁₆ x 41 ¹ / ₄ x 21 ⁷ / ₈
		557 x 1048 x 555	557 x 1048 x 555

3.14 Technical data heating boiler KBR 35-3

Input/Output	Unit	NG	LPG (Propane)
Max. input rate 180/79 °F (82/26 °C)	BTU/hr (kW)	131,900 (38.6)	129,100 (37.8)
Max. output rate 104/86 °F (40/30 °C)	BTU/hr (kW)	122,800 (36.0)	122,800 (36.0)
Max. output rate 122/86 °F (50/30 °C)	BTU/hr (kW)	121,800 (35.7)	121,800 (35.7)
Max. output rate 176/140 °F (80/60 °C)	BTU/hr (kW)	116,700 (34.2)	116,700 (34.2)
Min. input rate 180/79 (82/26 °C)	BTU/hr (kW)	36,000 (10.5)	46,400 (13.6)
Min. output rate 104/86 °F (40/30 °C)	BTU/hr (kW)	35,100 (10.3)	46,100 (13.5)
Min. output rate 122/86 °F (50/30 °C)	BTU/hr (kW)	34,800 (10.2)	45,700 (13.4)
Min. output rate 176/140 °F (80/60 °C)	BTU/hr (kW)	31,700 (9.3)	42,000 (12.3)
Gas connection value			
Natural gas - H ₂ = 1,010 BTU/ft ³ (37.3 MJ/m ³)	ft ³ /hr (m ³ /h)	130 (3.7)	-
Liquid Propane Gas - HD-S = 2,500 BTU/ft ³ (93.1 MJ/m ³)	ft ³ /hr (m ³ /h)	-	52 (1.5)
Permissible gas inlet pressure			
NG	in. W.C. (mbar)	3.5-10.5" (8.7-26.1)	-
LPG (Propane)	in. W.C. (mbar)	-	8-13" (19.9-32.3)
Flue gas			
Flue gas mass flow at maximum/minimum nominal output	gps	15.7/4.5	15.2/5.6
Flue gas temperature 176/140 °F (80/60 °C) at maximum/minimum nominal heat input	°F (°C)	162/135 (72/57)	162/135 (72/57)
Flue gas temperature 104/86 °F (40/30 °C) at maximum/minimum nominal heat input	°F (°C)	127/91 (53/33)	127/91 (53/33)
CO ₂ at maximum nominal output	%	9.4	11.0
CO ₂ at minimum nominal output	%	8.6	10.4
Condensate			
Maximum condensate quantity (t _R = 86 °F (30 °C))	gph (l/h)	0.32 (1.2)	0.32 (1.2)
pH level approx.		4.8	4.8
General			
Voltage	Vac	120	120
Frequency	Hz	60	60
Max. power consumption (central heating mode)	W	205	205
Max. power consumption (standby mode)	W	<6	<6
Sound pressure level	dB (A)	≤ 44	≤ 44
Max. supply temperature	°F (°C)	190 (88)	190 (88)
Max. permissible operating pressure (P _{MS}) heating	psi (bar)	30 (2.07)	30 (2.07)
Permissible ambient temperature	°F (°C)	32 - 122 (0 - 50)	32 - 122 (0 - 50)
Nominal water capacity (heating)	Gal (L)	0.925 (3.5)	0.925 (3.5)
Weight (without packaging)	lbs (kg)	132(60)	132(60)
Maximum overall dimensions W x H x D	inch (mm)	21 ¹⁵ / ₁₆ x 41 ¹ / ₄ x 21 ⁷ / ₈	21 ¹⁵ / ₁₆ x 41 ¹ / ₄ x 21 ⁷ / ₈
		557 x 1048 x 555	557 x 1048 x 555

3.15 Technical data heating boiler KBR 42-3

Input/Output at elevation 0 - 2000 feet (0 - 610 metres)	Unit	NG	LPG (Propane)
Max. input rate 180/79 °F (82/26 °C)	BTU/hr (kW)	151,600 (44.4)	148,300 (43.5)
Max. output rate 104/86 °F (40/30 °C)	BTU/hr (kW)	137,500 (40.3)	137,500 (40.3)
Max. output rate 122/86 °F (50/30 °C)	BTU/hr (kW)	137,500 (40.3)	137,500 (40.3)
Max. output rate 176/140 °F (80/60 °C)	BTU/hr (kW)	134,400 (39.4)	134,400 (39.4)
Min. input rate 180/79 (82/26 °C)	BTU/hr (kW)	36,000 (10.5)	46,400 (13.6)
Min. output rate 104/86 °F (40/30 °C)	BTU/hr (kW)	35,500 (10.4)	46,400 (13.6)
Min. output rate 122/86 °F (50/30 °C)	BTU/hr (kW)	35,100 (10.3)	46,100 (13.5)
Min. output rate 176/140 °F (80/60 °C)	BTU/hr (kW)	31,700 (9.3)	24,000 (12.3)
Input/Output at elevation 2000 - 4500 feet (611 - 1372 metres)			
Max. input rate 180/79 °F (82/26 °C)	BTU/hr (kW)	136,440 (40.0)	139,402 (40.9)
Max. output rate 104/86 °F (40/30 °C)	BTU/hr (kW)	123,750 (36.3)	129,250 (37.9)
Max. output rate 122/86 °F (50/30 °C)	BTU/hr (kW)	123,750 (36.3)	129,250 (37.9)
Max. output rate 176/140 °F (80/60 °C)	BTU/hr (kW)	120,960 (35.3)	126,336 (37.0)
Input/Output at elevation 4500 - 7000 feet (1373 - 2134 metres)			
Max. input rate 180/79 °F (82/26 °C)	BTU/hr (kW)	125,828 (36.9)	129,021 (37.8)
Max. output rate 104/86 °F (40/30 °C)	BTU/hr (kW)	114,125 (33.5)	119,625 (35.1)
Max. output rate 122/86 °F (50/30 °C)	BTU/hr (kW)	114,125 (33.5)	119,625 (35.1)
Max. output rate 176/140 °F (80/60 °C)	BTU/hr (kW)	111,552 (32.7)	116,928 (34.3)
Gas connection value			
Natural gas - H ₂ = 1,010 BTU/ft ³ (37.3 MJ/m ³)	ft ³ /hr (m ³ /h)	149 (4.2)	-
Liquid Propane Gas - HD-S = 2,500 BTU/ft ³ (93.1 MJ/m ³)	ft ³ /hr (m ³ /h)	-	59 (1.7)
Permissible gas inlet pressure			
NG	in. W.C. (mbar)	3.5-10.5" (8.7-26.1)	
LPG (Propane)	in. W.C. (mbar)	8-13" (19.9-32.3)	
Flue gas			
Flue gas mass flow at maximum/minimum nominal output	gps	18.0/4.5	17.5/5.6
Flue gas temperature 176/140 °F (80/60 °C) at maximum/minimum nominal heat input	°F (°C)	171/135 (77/57)	171/135 (77/57)
Flue gas temperature 104/86 °F (40/30 °C) at maximum/minimum nominal heat input	°F (°C)	133/91 (56/33)	133/91 (56/33)
CO ₂ at maximum nominal output	%	9.4	11.0
CO ₂ at minimum nominal output	%	8.6	10.4
Condensate			
Maximum condensate quantity (t _R = 86 °F (30 °C))	gph (i/h)	0.32 (1.2)	0.32 (1.2)
pH level approx.		4.8	4.8
General			
Voltage	Vac	120	120
Frequency	Hz	60	60
Max. power consumption (central heating mode)	W	205	205
Max. power consumption (standby mode)	W	<6	<6
Sound pressure level	dB (A)	≤ 45	≤ 45
Max. supply temperature	°F (°C)	190 (88)	190 (88)
Max. permissible operating pressure (P _{MS}) heating	psi (bar)	30 (2.07)	30 (2.07)
Permissible ambient temperature	°F (°C)	32 - 122 (0 - 50)	32 - 122 (0 - 50)
Nominal water capacity (heating)	Gal (L)	0.925 (3.5)	0.925 (3.5)
Weight (without packaging)	lbs (kg)	132(60)	132(60)
Maximum overall dimensions W x H x D	inch (mm)	21 ^{15/16} x 41 ^{1/4} x 21 ^{7/8} 557 x 1048 x 555	21 ^{15/16} x 41 ^{1/4} x 21 ^{7/8} 557 x 1048 x 555

3.16 Technical data combi boiler KWB 28-3

Input/Output	Unit	NG	LPG (Propane)
Max. input rate 180/79 °F (82/26 °C)	BTU/hr (kW)	100,800 (29.5)	98,600 (28.9)
Max. output rate 104/86 °F (40/30 °C)	BTU/hr (kW)	93,800 (27.5)	93,800 (27.5)
Max. output rate 122/86 °F (50/30 °C)	BTU/hr (kW)	93,100 (27.3)	93,100 (27.3)
Max. output rate 176/140 °F (80/60 °C)	BTU/hr (kW)	89,400 (26.2)	89,400 (26.2)
Output rate domestic hot water (DHW) 113 °F (45 °C)	BTU/hr (kW)	93,600 (27.4)	93,600 (27.4)
Output rate domestic hot water (DHW) 140 °F (60 °C)	BTU/hr (kW)	91,400 (26.8)	91,400 (26.8)
Min. input rate 180/79 (82/26 °C)	BTU/hr (kW)	24,600 (7.2)	40,100 (11.7)
Min. output rate 104/86 °F (40/30 °C)	BTU/hr (kW)	23,900 (7.0)	39,900 (11.7)
Min. output rate 122/86 °F (50/30 °C)	BTU/hr (kW)	23,900 (7.0)	39,600 (11.6)
Min. output rate 176/140 °F (80/60 °C)	BTU/hr (kW)	21,800 (6.4)	36,200 (10.6)
Gas connection value			
Natural gas - H _s = 1,010 BTU/ft ³ (37.3 MJ/m ³)	ft ³ /hr (m ³ /h)	99 (2.8)	-
Liquid Propane Gas - HD-S = 2,500 BTU/ft ³ (93.1 MJ/m ³)	ft ³ /hr (m ³ /h)	-	39 (1.1)
Permissible gas inlet pressure			
NG	in. W.C. (mbar)	3.5-10.5" (8.7-26.1)	
LPG (Propane)	in. W.C. (mbar)	8-13" (19.9-32.3)	
Expansion vessel			
Pre-charge pressure	psi (bar)	10.9 (0.75)	10.9 (0.75)
Total contents	Gal (L)	3.17 (12)	3.17 (12)
DHW			
Max. DHW flow rate	gpm (l/min)	2.64 (10)	2.64 (10)
Nominal DHW flow rate (at 140 °F (60 °C) outlet temperature)	gpm (l/min)	2.03 (7.7)	2.03 (7.7)
Outlet temperature	°F (°C)	104 - 140 (40 - 60)	104 - 140 (40 - 60)
Max. cold water inlet temperature	°F (°C)	140 (60)	140 (60)
Max. approved DHW pressure	psi (bar)	150 (10.3)	150 (10.3)
Minimum water pressure	psi (bar)	4.35 (0.3)	4.35 (0.3)
Flue gas			
Flue gas mass flow at maximum/minimum nominal output	gps	12.0/3.2	11.7/4.9
Flue gas temperature 176/140 °F (80/60 °C) at max./min. nominal heat input	°F (°C)	147/133 (64/56)	147/133 (64/56)
Flue gas temperature 104/86 °F (40/30 °C) at max./min. nominal heat input	°F (°C)	117/90 (47/32)	117/90 (47/32)
CO ₂ at maximum nominal output	%	9.4	11.0
CO ₂ at minimum nominal output	%	8.6	10.4
Condensate			
Maximum condensate quantity (t _R = 86 °F (30 °C))	gph (l/h)	0.32 (1.2)	0.32 (1.2)
pH level approx.		4.8	4.8
General			
Voltage	Vac	120	120
Frequency	Hz	60	60
Max. power consumption (central heating mode)	W	205	205
Max. power consumption (standby mode)	W	<6	<6
Sound pressure level	dB (A)	≤ 39	≤ 39
Max. supply temperature	°F (°C)	190 (88)	190 (88)
Max. permissible operating pressure (P _{MS}) heating	psi (bar)	30 (2.07)	30 (2.07)
Permissible ambient temperature	°F (°C)	32 - 122 (0 - 50)	32 - 122 (0 - 50)
Nominal water capacity (heating)	Gal (L)	0.925 (3.5)	0.925 (3.5)
Weight (without packaging)	lbs (kg)	136.5(62)	136.5(62)
Maximum overall dimensions W x H x D	inch (mm)	23 11/16 x 41 1/4 x 21 7/8 602 x 1048 x 555	23 11/16 x 41 1/4 x 21 7/8 602 x 1048 x 555

3.17 Technical data combi boiler KWB 35 - 3

Input/Output	Unit	NG	LPG (Propane)
Max. input rate 180/79 °F (82/26 °C)	BTU/hr (kW)	131,900 (38.6)	129,100 (37.8)
Max. output rate 104/86 °F (40/30 °C)	BTU/hr (kW)	122,800 (36.0)	122,800 (36.0)
Max. output rate 122/86 °F (50/30 °C)	BTU/hr (kW)	121,800 (35.7)	121,800 (35.7)
Max. output rate 176/140 °F (80/60 °C)	BTU/hr (kW)	116,700 (34.2)	116,700 (34.2)
Output rate domestic hot water (DHW) 113 °F (45 °C)	BTU/hr (kW)	120,500 (35.3)	120,500 (35.3)
Output rate domestic hot water (DHW) 140 °F (60 °C)	BTU/hr (kW)	118,700 (34.8)	118,700 (34.8)
Min. input rate 180/79 (82/26 °C)	BTU/hr (kW)	36,000 (10.5)	46,400 (13.6)
Min. output rate 104/86 °F (40/30 °C)	BTU/hr (kW)	35,100 (10.3)	46,100 (13.5)
Min. output rate 122/86 °F (50/30 °C)	BTU/hr (kW)	34,800 (10.2)	45,700 (13.4)
Min. output rate 176/140 °F (80/60 °C)	BTU/hr (kW)	31,700 (9.3)	42,000 (12.3)
Gas connection value			
Natural gas - H _s = 1,010 BTU/ft ³ (37.3 MJ/m ³)	ft ³ /hr (m ³ /h)	130 (3.7)	-
Liquid Propane Gas - HD-S = 2,500 BTU/ft ³ (93.1 MJ/m ³)	ft ³ /hr (m ³ /h)	-	52 (1.5)
Permissible gas inlet pressure			
NG	in. W.C. (mbar)	3.5-10.5" (8.7-26.1)	
LPG (Propane)	in. W.C. (mbar)	8-13" (19.9-32.3)	
Expansion vessel			
Pre-charge pressure	psi (bar)	10.9 (0.75)	10.9 (0.75)
Total contents	Gal (L)	3.17 (12)	3.17 (12)
DHW			
Max. DHW flow rate	gpm (l/min)	3.17 (12)	3.17 (12)
Nominal DHW flow rate (at 140 °F (60 °C) outlet temperature)	gpm (l/min)	2.6 (10)	2.6 (10)
Outlet temperature	°F (°C)	104 - 140 (40 - 60)	104 - 140 (40 - 60)
Max. cold water inlet temperature	°F (°C)	140 (60)	140 (60)
Max. approved DHW pressure	psi (bar)	150 (10.3)	150 (10.3)
Minimum water pressure	psi (bar)	4.35 (0.3)	4.35 (0.3)
Flue gas			
Flue gas mass flow at maximum/minimum nominal output	gps	15.7/4.5	15.2/5.6
Flue gas temperature 176/140 °F (80/60 °C) at max./min. nominal heat input	°F (°C)	162/135 (72/57)	162/135 (72/57)
Flue gas temperature 104/86 °F (40/30 °C) at max./min. nominal heat input	°F (°C)	127/91 (53/33)	127/91 (53/33)
CO ₂ at maximum nominal output	%	9.4	11.0
CO ₂ at minimum nominal output	%	8.6	10.4
Condensate			
Maximum condensate quantity (t _R = 86 °F (30 °C))	gph (l/h)	0.32 (1.2)	0.32 (1.2)
pH level approx.		4.8	4.8
General			
Voltage	Vac	120	120
Frequency	Hz	60	60
Max. power consumption (central heating mode)	W	205	205
Max. power consumption (standby mode)	W	<6	<6
Sound pressure level	dB (A)	≤ 44	≤ 44
Max. supply temperature	°F (°C)	190 (88)	190 (88)
Max. permissible operating pressure (P _{MS}) heating	psi (bar)	30 (2.07)	30 (2.07)
Permissible ambient temperature	°F (°C)	32 - 122 (0 - 50)	32 - 122 (0 - 50)
Nominal water capacity (heating)	Gal (L)	0.925 (3.5)	0.925 (3.5)
Weight (without packaging)	lbs (kg)	136.5(62)	136.5(62)
Maximum overall dimensions W x H x D	inch (mm)	23 11/16 x 41 1/4 x 21 7/8 602 x 1048 x 555	23 11/16 x 41 1/4 x 21 7/8 602 x 1048 x 555

3.18 Technical data combi boiler KWB 42 - 3

Input/Output	Unit	NG	LPG (Propane)
Max. input rate 180/79 °F (82/26 °C)	BTU/hr (kW)	151,600 (44.4)	148,300 (43.5)
Max. output rate 104/86 °F (40/30 °C)	BTU/hr (kW)	137,500 (40.3)	137,500 (40.3)
Max. output rate 122/86 °F (50/30 °C)	BTU/hr (kW)	137,500 (40.3)	137,500 (40.3)
Max. output rate 176/140 °F (80/60 °C)	BTU/hr (kW)	134,400 (39.4)	134,400 (39.4)
Output rate domestic hot water (DHW) 113 °F (45 °C)	BTU/hr (kW)	137,500 (40.3)	137,500 (40.3)
Output rate domestic hot water (DHW) 140 °F (60 °C)	BTU/hr (kW)	135,800 (39.8)	135,800 (39.8)
Min. input rate 180/79 (82/26 °C)	BTU/hr (kW)	36,000 (10.5)	46,400 (13.6)
Min. output rate 104/86 °F (40/30 °C)	BTU/hr (kW)	35,500 (10.4)	46,400 (13.6)
Min. output rate 122/86 °F (50/30 °C)	BTU/hr (kW)	35,100 (10.3)	46,100 (13.5)
Min. output rate 176/140 °F (80/60 °C)	BTU/hr (kW)	31,700 (9.3)	42,000 (12.3)
Input/Output at elevation 2000 - 4500 feet (611 - 1372 metres)			
Max. input rate 180/79 °F (82/26 °C)	BTU/hr (kW)	136,440 (40.0)	139,402 (40.9)
Max. output rate 104/86 °F (40/30 °C)	BTU/hr (kW)	123,750 (36.3)	129,250 (37.9)
Max. output rate 122/86 °F (50/30 °C)	BTU/hr (kW)	123,750 (36.3)	129,250 (37.9)
Max. output rate 176/140 °F (80/60 °C)	BTU/hr (kW)	120,960 (35.5)	126,336 (37.0)
Output rate domestic hot water (DHW) 113 °F (45 °C)	BTU/hr (kW)	123,750 (36.3)	129,750 (37.9)
Output rate domestic hot water (DHW) 140 °F (60 °C)	BTU/hr (kW)	122,220 (35.8)	127,652 (37.4)
Input/Output at elevation 4500 - 7000 feet (1373 - 2134 metres)			
Max. input rate 180/79 °F (82/26 °C)	BTU/hr (kW)	125,828 (36.9)	129,021 (37.8)
Max. output rate 104/86 °F (40/30 °C)	BTU/hr (kW)	114,125 (33.5)	119,625 (35.1)
Max. output rate 122/86 °F (50/30 °C)	BTU/hr (kW)	114,125 (33.5)	119,625 (35.1)
Max. output rate 176/140 °F (80/60 °C)	BTU/hr (kW)	111,552 (32.7)	116,928 (34.3)
Output rate domestic hot water (DHW) 113 °F (45 °C)	BTU/hr (kW)	114,125 (33.5)	119,625 (35.1)
Output rate domestic hot water (DHW) 140 °F (60 °C)	BTU/hr (kW)	112,714 (33.0)	118,148 (34.6)
Gas connection value			
Natural gas - H _s = 1,010 BTU/ft ³ (37.3 MJ/m ³)	ft ³ /hr (m ³ /h)	149 (4.2)	-
Liquid Propane Gas - HD-S = 2,500 BTU/ft ³ (93.1 MJ/m ³)	ft ³ /hr (m ³ /h)	-	59 (1.7)
Permissible gas inlet pressure			
NG	in. W.C. (mbar)	3.5-10.5" (8.7-26.1)	-
LPG (Propane)	in. W.C. (mbar)	-	8-13" (19.9-32.3)
Expansion vessel			
Pre-charge pressure	psi (bar)	10.9 (0.75)	10.9 (0.75)
Total contents	Gal (L)	3.17 (12)	3.17 (12)
DHW			
Max. DHW flow rate	gpm (l/min)	3.963 (15)	3.963 (15)
Nominal DHW flow rate (at 140 °F (60 °C) outlet temperature)	gpm (l/min)	3.61 (11.4)	3.61 (11.4)
Outlet temperature	°F (°C)	104 - 140 (40 - 60)	104 - 140 (40 - 60)
Max. cold water inlet temperature	°F (°C)	140 (60)	140 (60)
Max. approved DHW pressure	psi (bar)	150 (10.3)	150 (10.3)
Minimum water pressure	psi (bar)	4.35 (0.3)	4.35 (0.3)
Flue gas			
Flue gas mass flow at maximum/minimum nominal output	gps	18.0/4.5	17.5/5.6
Flue gas temperature 176/140 °F (80/60 °C) at max./min. nominal heat input	°F (°C)	171/135 (77/57)	171/135 (77/57)
Flue gas temperature 104/86 °F (40/30 °C) at max./min. nominal heat input	°F (°C)	133/91 (56/33)	133/91 (56/33)
CO ₂ at maximum nominal output	%	9.4	11.0
CO ₂ at minimum nominal output	%	8.6	10.4
Condensate			
Maximum condensate quantity (t _R = 86 °F (30 °C))	gph (i/h)	0.32 (1.2)	0.32 (1.2)
pH level approx.		4.8	4.8
General			

Input/Output	Unit	NG	LPG (Propane)
Voltage	Vac	120	120
Frequency	Hz	60	60
Max. power consumption (central heating mode)	W	205	205
Max. power consumption (standby mode)	W	<6	<6
Sound pressure level	dB (A)	≤ 45	≤ 45
Max. supply temperature	°F (°C)	190 (88)	190 (88)
Max. permissible operating pressure (P _{MS}) heating	psi (bar)	30 (2.07)	30 (2.07)
Permissible ambient temperature	°F (°C)	32 - 122 (0 - 50)	32 - 122 (0 - 50)
Nominal water capacity (heating)	Gal (L)	0.925 (3.5)	0.925 (3.5)
Weight (without packaging)	lbs (kg)	136.5(62)	136.5(62)
Maximum overall dimensions W x H x D	inch (mm)	23 ^{11/16} x 41 ^{1/4} x 21 ^{7/8} 602 x 1048 x 555	23 ^{11/16} x 41 ^{1/4} x 21 ^{7/8} 602 x 1048 x 555

3.19 Condensate composition

The condensate volume and ingredients may change with regionally and seasonally varying gas quality and air quality. Typically the following ingredients and concentrations can be expected:

Substance	Value in ppm (mg/l)
Ammonium	1.2
Lead	≤ 0.01
Cadmium	≤ 0.001
Chrome	≤ 0.005
Halogenated hydrocarbons	≤ 0.002
Hydrocarbons	0.015
Copper	0.028
Nickel	≤ 0.1
Mercury	≤ 0.0001
Sulfate	1
Zinc	≤ 0.015
Tin	≤ 0.01
Vanadium	≤ 0.001
pH-value	4.8

Table 2 Typical condensate composition

4 Regulations



Observe all rules, regulations, standards and guidelines applicable to the installation and operation of this appliance according to local, state and federal regulations.



Valves external to the boiler must be fitted with T-handles and condensate piping must be installed in accordance with the State Plumbing Code.

4.1 Compliance with standards and regulations

The installation must conform to the requirements of the authority having jurisdiction or, in the absence of such requirements, to the latest edition of the National Fuel Gas Code, ANSI Z223.1./NFPA 54. In Canada, installation must be in accordance with the requirements of CAN/CSA B149.1, Natural Gas and Propane Installation Code.

This floor standing condensing gas boiler complies in its design and mode of operation with the American National Standard ANSI Z21.13/CSA4.9, latest edition for Gas Fired Low Pressure Steam and Hot Water Boilers.

Other confirmed approvals and certifications are indicated by labels on the boiler.

Where required by the authority having jurisdiction, the installation must conform to the Standard for Controls and Safety Devices for Automatically Fired Boilers, ANSI/ASME CSD-1.

Install CO detectors per local regulations. Boiler requires yearly maintenance (→ chapter 15, page 62).

4.2 Operating limits of the boiler

The heat exchanger has been designed and certified in accordance with the ASME Boiler and Pressure Vessel Code, Section IV.

Maximum boiler temperature	190 °F (88 °C)
Maximum operating pressure	30 psi (2.07 bar)

Table 3 Operating limits

The hot water distribution system must comply with all applicable codes and regulations. When replacing an existing boiler, it is important to check the condition of the entire hot water distribution system to ensure safe operation. Common practice calls for inspecting an existing system in its entirety and bringing it up to code. All pipe work should be properly cleaned and flushed.

4.3 Additional regulations for installation in Massachusetts

(a) For all side wall horizontally vented gas fueled equipment installed in every dwelling, building or structure used in whole or in part for residential purposes, including those owned or operated by the Commonwealth and where the side wall exhaust vent termination is less than seven (7) feet [2150 mm] above finished grade in the area of the venting, including but not limited to decks and porches, the following requirements shall be satisfied:

- **INSTALLATION OF CARBON MONOXIDE DETECTORS.**
At the time of installation of the side wall horizontal vented gas fueled equipment, the installing plumber or gas fitter shall observe that a hard wired carbon monoxide detector with an alarm and battery back-up is installed on the floor level where the gas equipment is to be installed. In addition, the installing plumber or gas fitter shall observe that a battery operated or hard wired carbon monoxide detector with an alarm is installed on each additional level of the dwelling, building or structure served by the side wall horizontal vented gas fueled equipment. It shall be the responsibility of the property owner to secure the services of qualified licensed professionals for the installation of hard wired carbon monoxide detectors.
 - In the event that the side wall horizontally vented gas fueled equipment is installed in a crawl space or an attic, the hard wired carbon monoxide detector with alarm and battery back-up may be installed on the next adjacent floor level.
 - In the event that the requirements of this subdivision can not be met at the time of completion of installation, the owner shall have a period of thirty (30) days to comply with the above requirements; provided, however, that during said thirty (30) day period, a battery operated carbon monoxide detector with an alarm shall be installed.
- **APPROVED CARBON MONOXIDE DETECTORS.**
Each carbon monoxide detector as required in accordance with the above provisions shall comply with NPA 720 and be ANSI/UL 2034 listed and IAS certified.
- **SIGNAGE.**
A metal or plastic identification plate shall be permanently mounted to the exterior of the building at a minimum height of eight (8) feet above grade directly in line with the exhaust vent terminal for the horizontally vented gas fueled heating appliance or equipment. The sign shall read, in print size no less than one-half (½) inch in size, “GAS VENT DIRECTLY BELOW. KEEP CLEAR OF ALL OBSTRUCTIONS”.
- **INSPECTION.** The state or local gas inspector of the side wall horizontally vented gas fueled equipment shall not approve the installation unless, upon inspections, the inspector observes carbon monoxide detectors and signage installed in accordance with the provisions of 248 CRM 5.08(2)(a) 1 through 4.

(b) EXEMPTIONS:

The following equipment is exempt from 248 CRM 5.08(2)(a) 1 thru 4:

- The equipment listed in Chapter 10 entitled “Equipment Not Required To Be Vented” in the most current edition of NFPA 54 as adopted by the board; and
- Product Approved side wall horizontally vented gas fueled equipment installed in a room or structure separate from the dwelling, building or structure used in whole or in part for residential purposes.

(c) MANUFACTURERS REQUIREMENTS - GAS EQUIPMENT VENTING SYSTEM REQUIRED.

When the manufacturer of Product Approved side wall horizontally mounted gas equipment provides a venting system design or venting system components with the equipment, the instructions provided by the manufacturer for the installation of the equipment and venting shall include:

- Detailed instructions for the installation of the venting system or the venting system components; and
- A complete parts list for the venting system design or venting system.

(d) MANUFACTURERS REQUIREMENTS - GAS EQUIPMENT VENTING SYSTEM NOT PROVIDED.

When the manufacturer of Product Approved side wall horizontally vented gas fueled equipment does not provide the parts for the venting of flue gases, but identifies special venting systems, the following requirements shall be satisfied by the manufacturer:

- The referenced special venting systems shall be included with the appliance or equipment installation instructions; and
- The special venting systems shall be Product Approved by the Board, and the instructions for that system shall include a parts list and detailed installation instructions.

(e) A copy of all instructions for all Product Approved side wall horizontally vented gas fueled equipment, all venting instructions, all parts lists for venting instructions, and/or venting design instructions shall remain with the appliance or equipment at the completion of the installation.

5 Common Applications of KBR boilers

5.1 Multiple zones using zone valves with DHW

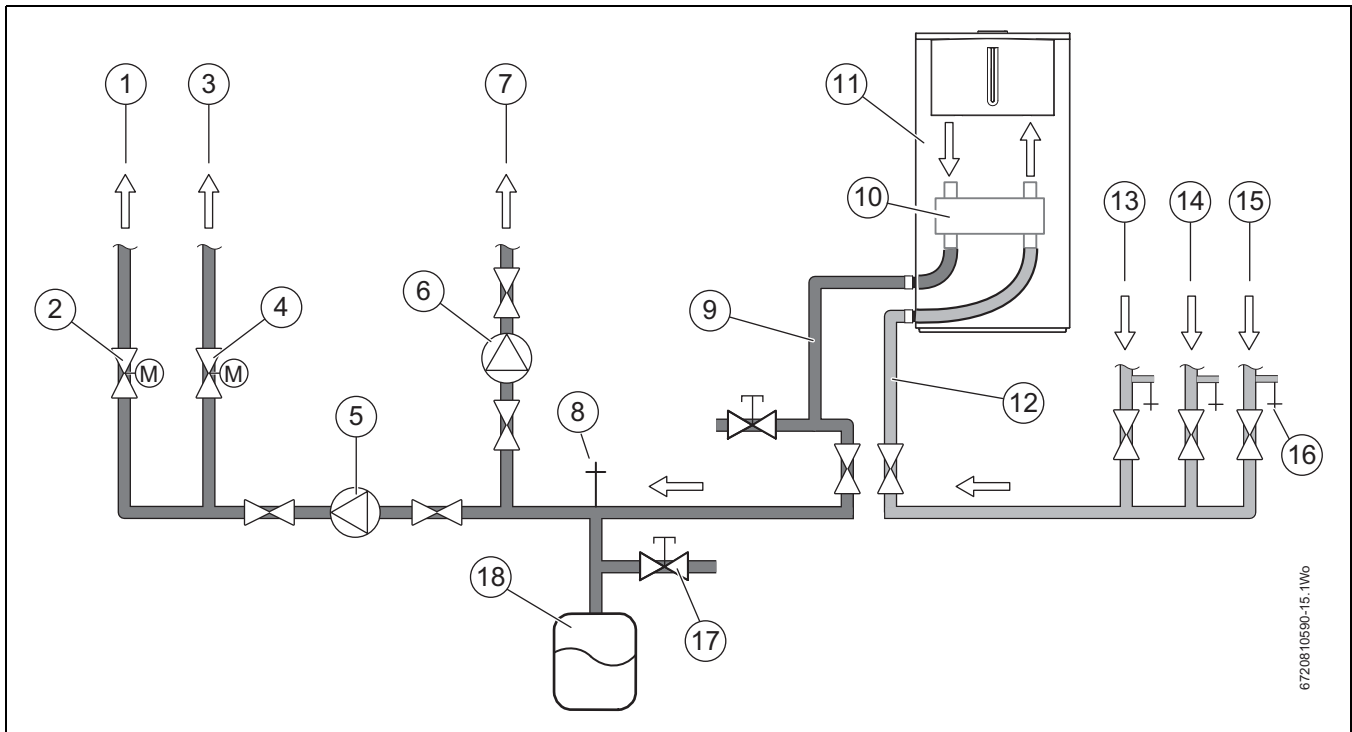

Fig. 10 Piping

- [1] Supply to heating zone 2
- [2] Motorized valve heating zone 2
- [3] Supply to heating zone 1
- [4] Motorized valve heating zone 1
- [5] System pump
- [6] DHW pump
- [7] Supply to indirect tank
- [8] Drain/Bleed point
- [9] Boiler supply pipe 1¼"
- [10] Low Loss Header
- [11] Heat only boiler
- [12] Boiler return pipe 1¼"
- [13] Return from indirect tank
- [14] Return from heating zone 1
- [15] Return from heating zone 2
- [16] Drain/Bleed point
- [17] Combination fast fill/back flow preventer
- [18] Expansion (tank) vessel

5.1.1 To utilize the LLH

- ▶ Switch off and isolate the boiler
 - ▶ Drain the boiler
 - ▶ Remove front panel
 - ▶ Locate the LLH at the left-hand side of the lower section of the boiler
1. Unscrew the cap [a] from the body of the LLH [c]
 - This will break the label across the cap and body indicating that the LLH has been employed
 2. Withdraw the cap [a] and plunger assembly [b]
 3. Unscrew the plunger assembly [b] from the cap [a],
 4. Set the plunger assembly [b] aside
 5. Re-fit the cap [a] without the plunger assembly [b]
 6. Tighten the cap [a] and ensure it is secure.

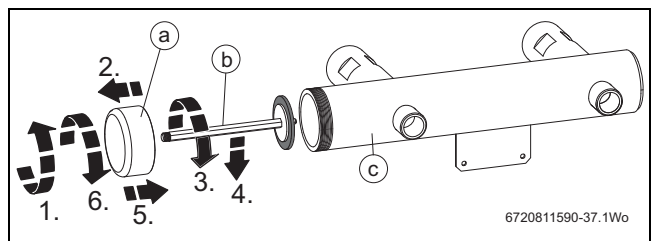

Fig. 11 Utilizing the LLH

5.1.2 Wiring - Multi zone with zone valves and LWCO



When using CZM100 and CRC100 or CRC200 controls the factory installed jumper at terminal [2e] remains.

The LWCO jumper on terminal [2g] is removed when using a LWCO.

For LWCO function an external transformer is required

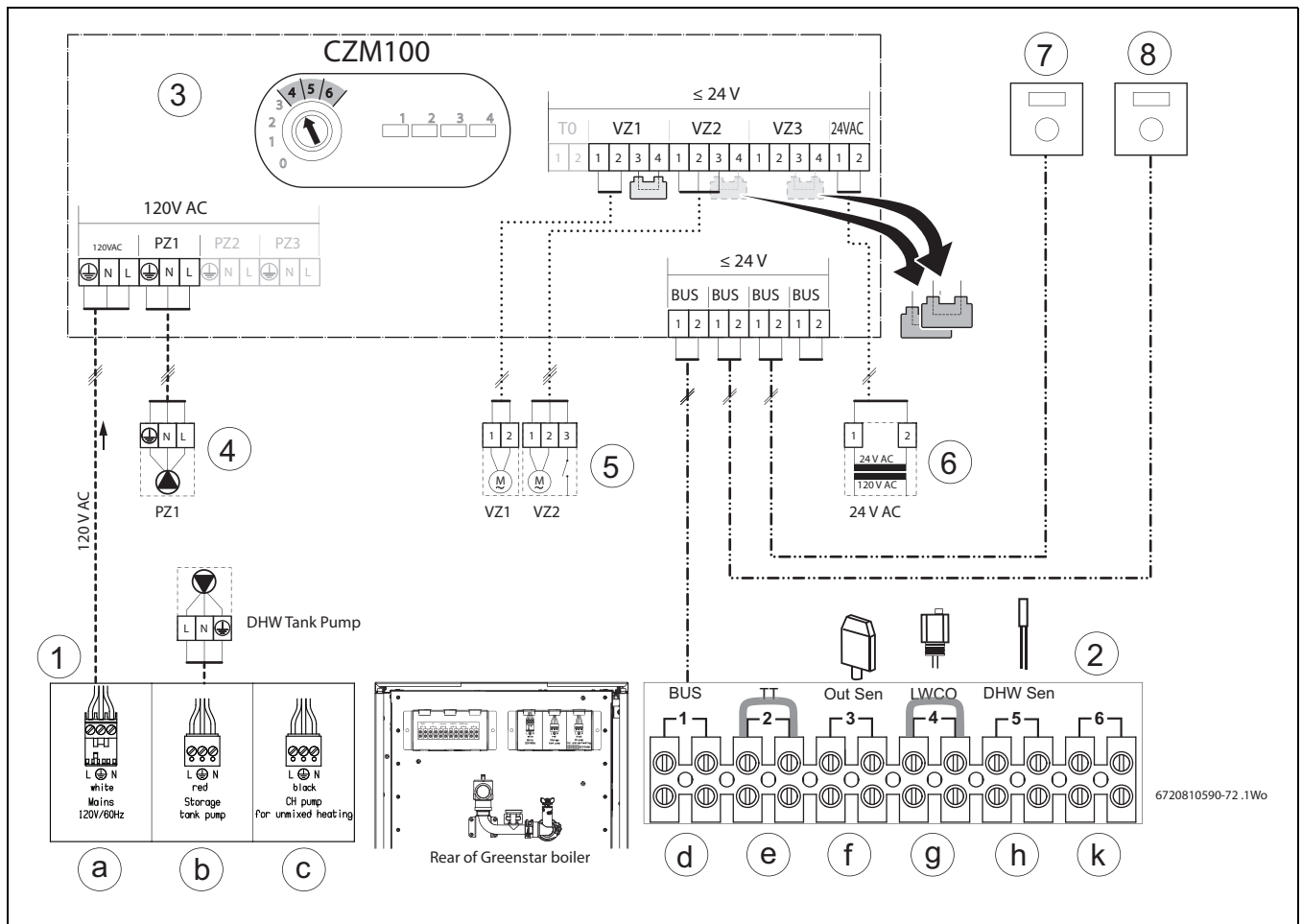

Fig. 12 Wiring

- [1] High Voltage connection box
- [1a] 120 V AC mains power (white plug)
- [1b] DHW Storage tank circulator pump (red plug)
- [1c] System circulator pump (black plug)
- [2] Low Voltage connection box
- [2d] BUS EMS connection
- [2e] TT - Thermostat/On demand signal (pre-wired link) (dry signal)
- [2f] Out Sen - (Outdoor sensor, sold separately)
- [2g] LWCO - (pre-wired link) (Low Water Cut Off switch, sold separately)
- [2h] DHW Sen - (Tank sensor)
- [2k] Empty (future connectivity)
- [3] CZM100 (Comfort Zone Manager 100)
- [4] PZ1 - System pump
- [5] VZ1, VZ2 - Zone valves
- [6] 24V Transformer
- [7] CRC100 or CRC200 Zone 1 (Comfort room controller)
- [8] CRC100 or CRC200 Zone 2 (Comfort room controller)

5.2 Multiple zones using circulators with DHW

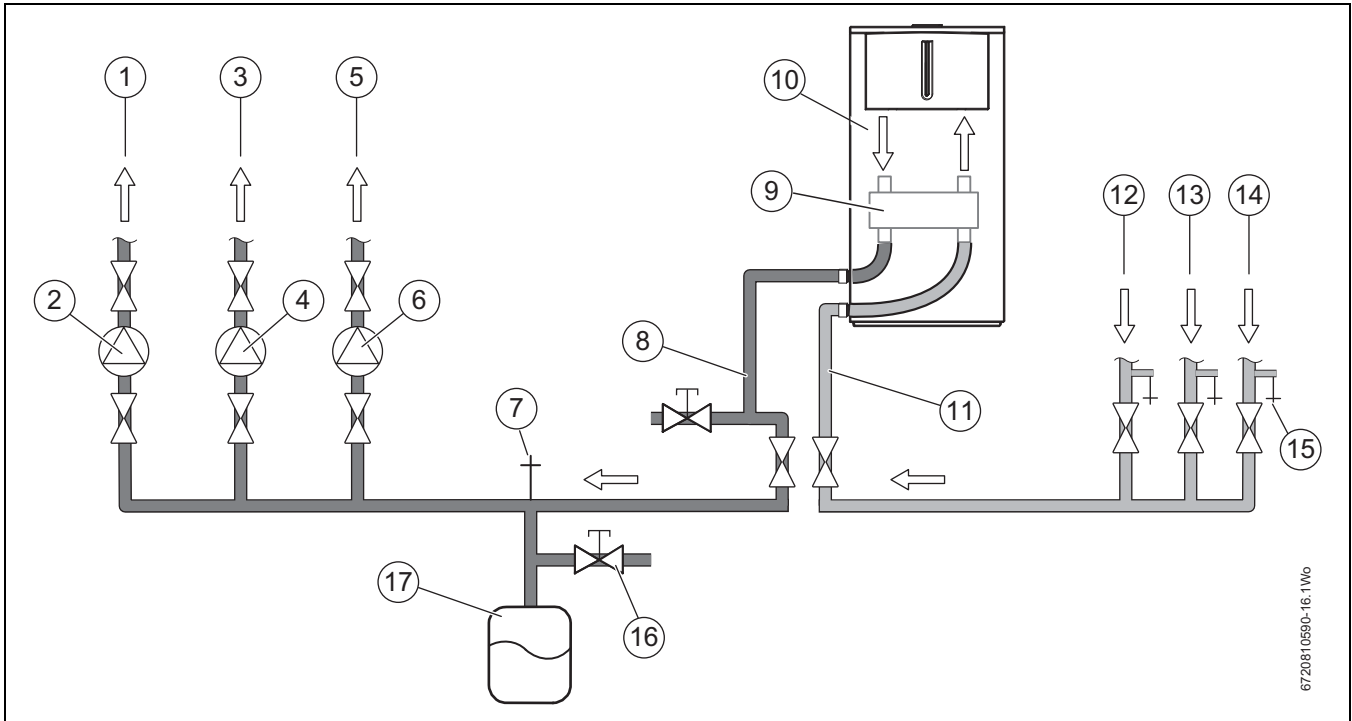

Fig. 13 Piping

- [1] Supply to heating zone 2
- [2] Pump heating zone 2
- [3] Supply to heating zone 1
- [4] Pump heating zone 1
- [5] Supply to indirect tank
- [6] DHW pump
- [7] Drain/Bleed point
- [8] Boiler supply pipe 1¼"
- [9] Low Loss Header
- [10] Heat only boiler
- [11] Boiler return pipe 1¼"
- [12] Return from indirect tank
- [13] Return from heating zone 1
- [14] Return from heating zone 2
- [15] Grain/Bleed point x3
- [16] Combination fast fill/back flow preventer
- [17] Expansion (tank) vessel

5.2.1 To utilize the LLH

- ▶ Switch off and isolate the boiler
 - ▶ Drain the boiler
 - ▶ Remove front panel
 - ▶ Locate the LLH at the left-hand side of the lower section of the boiler
1. Unscrew the cap [a] from the body of the LLH [c]
 - This will break the label across the cap and body indicating that the LLH has been employed
 2. Withdraw the cap [a] and plunger assembly [b]
 3. Unscrew the plunger assembly [b] from the cap [a],
 4. Set the plunger assembly [b] aside
 5. Re-fit the cap [a] without the plunger assembly [b]
 6. Tighten the cap [a] and ensure it is secure.

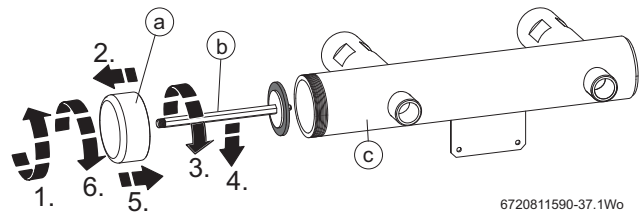

Fig. 14 Utilizing the LLH

5.2.2 Wiring



When using CZM100 and CRC100 or CRC200 controls the factory installed jumper at terminal [2e] remains.

The LWCO jumper on terminal [2g] is removed when using a LWCO.

For LWCO function an external transformer is required

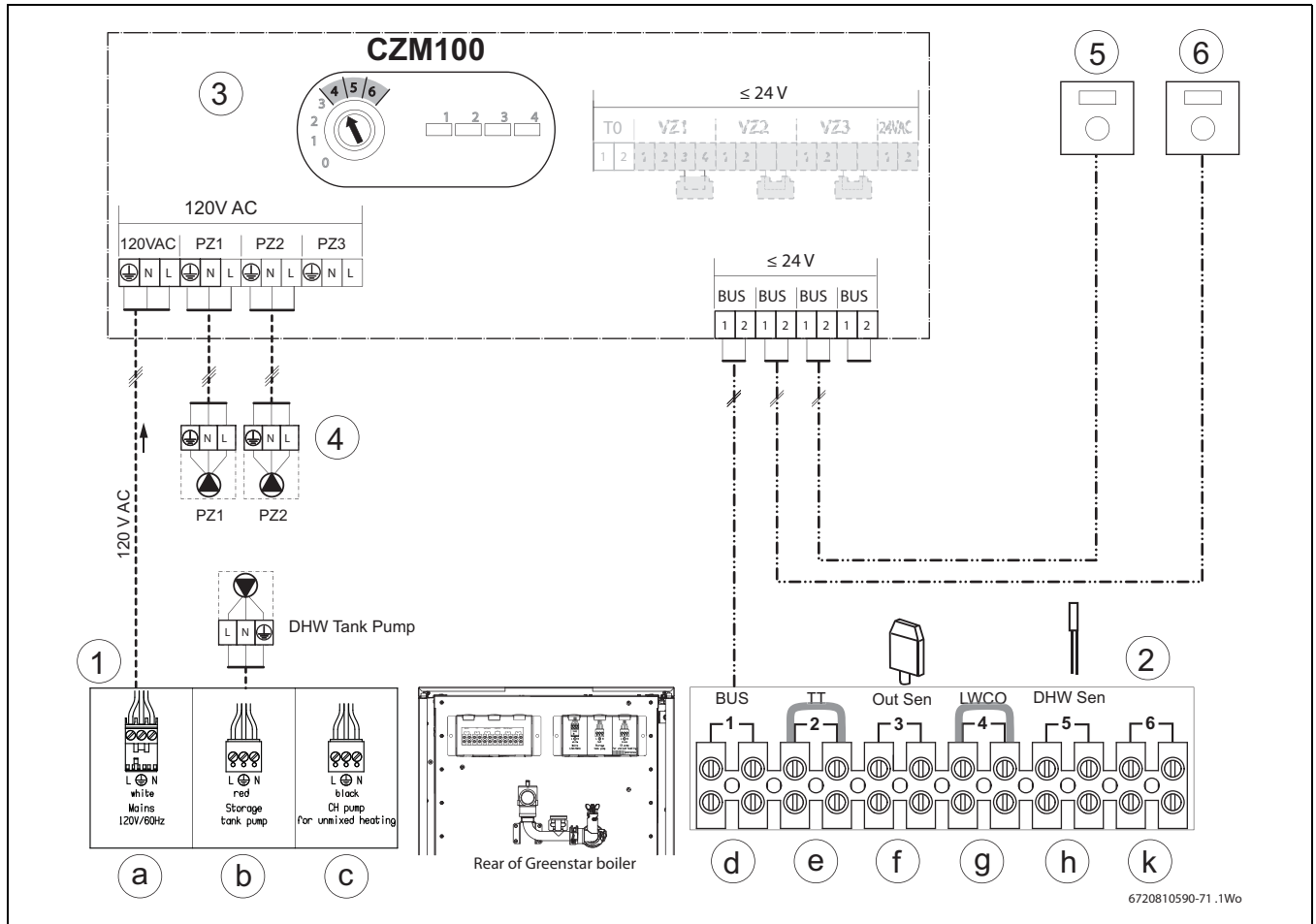

Fig. 15 Wiring

- [1] High Voltage connection box
- [1a] 120 V AC mains power (white plug)
- [1b] DHW Storage tank circulator pump (red plug)
- [1c] System circulator pump (black plug)
- [2] Low Voltage connection box
- [2d] BUS EMS connection
- [2e] TT - Thermostat/On demand signal (pre-wired link) (dry signal)
- [2f] Out Sen - (Outdoor sensor, sold separately)
- [2g] LWCO - (pre-wired link) (Low Water Cut Off switch, sold separately)
- [2h] DHW Sen - (Tank sensor)
- [2k] Empty (future connectivity)
- [3] CZM100 (Comfort Zone Manager 100)
- [4] PZ1, PZ2 - Zone circulator pumps
- [5] CRC100 or CRC200 Zone 1 (Comfort room controller)
- [6] CRC100 or CRC200 Zone 2 (Comfort room controller)

6 Installation



DANGER: Explosion!

- ▶ Close the gas cock prior to working on the gas train.
- ▶ Check for gas leaks after carrying out work on the gas train.



Installation, power connection, connection on the gas and flue gas side and commissioning must only be carried out by a contractor certified for such work by the state or local jurisdiction or the local gas or power utility.



Transportation blank plugs

- ▶ Remove the blanking plugs from the appliance water connections. There may be some water present from the appliance testing.

6.1 Installation and operation

When installing and operating the heating system observe the following:

- The elevation of the installation location above sea level must be taken into account (→ Chapter 12.1).
- Follow all local building regulations regarding the installation conditions on site.
- The local building regulations regarding air supply and venting systems and the chimney flue connection.
- Electrical code requirements for connection to the electrical power supply.
- The technical regulations of the gas company regarding the connection of the gas burner to the local gas main.
- The regulations and standards relating to the DHW heating system.

6.1.1 Notes on installation and operation

Fill and make-up water for the heating system

Unsuitable fill and make-up water can result in the heating system scaling up or failing prematurely.

Recommended steps for commissioning a new or retrofit boiler installation

- ▶ Flush the system with clean water.
- ▶ Isolate the boiler, fill the system with fresh water and a boiler cleaner, run for 30 minutes to 1 hour. Under no circumstances may boiler cleaner be pumped through the boiler.
- ▶ Thoroughly flush the system with fresh water. Ensure all zones and loops are flushed.
- ▶ Empty out sediment traps.
- ▶ Systems containing antifreeze not approved by Bosch, must be completely flushed to ensure no old fluid remains.
- ▶ Fill the system with fresh water and the proper amount of inhibitor.
- ▶ Verify the pH is within the proper range.
- ▶ Add additional inhibitor if pH is not within the proper range.
- ▶ Check pH annually.
- ▶ If using antifreeze, fill with approved antifreeze and fresh water.
- ▶ Always follow the cleaner, antifreeze, or additive manufacturer's instructions.
- ▶ Do not mix different manufacturer's products
- ▶ Follow manufacturer's data to determine the anti-freeze ratio for the desired freeze protection temperature.

Recirculation pump/DHW recirculation lines

Total length DHW/recirculation line	Flow rate
≤ 33 ft (10 m)	0.66 gpm (2.5 l/min)
33 - 66 ft (10 - 20 m)	0.92 gpm (3.5 l/min)
66 - 98 ft (20 - 30 m)	1.32 gpm (5 l/min)

Table 4 Recommended flow rates



Use service function **6.d**, to determine the current flow rate (→ page 57).

Electrical connection of the DHW recirculation pump (→ page 45).

Connect the DHW recirculation line as close as possible to the cold water inlet on the appliance.

Open vented heating systems

- ▶ Convert open vented heating systems into closed systems.

Gravity heating systems

- ▶ Connect the appliance to the existing piping system via an external low-loss header with a sludge separator.

Galvanized radiators or pipes.

To prevent gas formation:

- ▶ Do not use galvanized radiators or pipes.

Plastic pipe work

If using plastic pipe work for the heating system (eg. underfloor/radiant heating), the type of pipe that should be used must be oxygen tight.

Use of a room temperature control

- ▶ Do not install thermostatic valves on radiators in the primary room.

Primary-secondary piping or a Low Loss Header (LLH)



Enable the integrated Low Loss Header if hydraulic separation is required and not already provided by a configuration external to the appliance.

Typically all multi zone applications with any combination of emitters like baseboard, panel radiator or radiant would require primary secondary piping or a low loss header for hydraulic separation.

In addition to that some larger single zone applications exceeding a flow rate of 4.0 gpm requires primary secondary piping or a low loss header to achieve hydraulic balance.

A Low Loss Header is used to achieve hydraulic balance on either side of the appliance, using the lowest pump speed that delivers heat to all the radiators in the system.

Radiant floor, panel radiator, multi zone and application systems exceeding 70' (21 m) of 3/4" baseboard at a 20°F delta T and a flow rate of 4.0 gpm plus the necessary supply and return piping, require primary-secondary piping or a low loss header for hydraulic separation of the system from the boiler.

Water Chemistry Guidelines

NOTICE: Insufficient antifreeze can accelerate corrosion.

- ▶ Follow manufacturer's instructions on antifreeze concentration.
- ▶ Frost protection level must be checked annually during regular scheduled maintenance of the boiler.

NOTICE: System damage!

- ▶ It is the installer's responsibility to ensure that the heating system is compatible with the boiler type and size installed.
- ▶ Keep pH-value of the heating water between 7 & 8.5.

The following anti-freeze fluids and concentrations have been approved:

Chemical Name	Concentration
Nalco (Varidos) FSK	22 - 55 %
Fernox Alphi 11	Refer to manufacturer's instructions
Intercool NFP-50 AA	0 - 39 %
Antifrogen N	Refer to manufacturer's instructions
NoBurst AL	0 - 55 %

Table 5 Anti-freeze

Corrosion inhibitors

The following anti-corrosion agents are approved:

Chemical Name	Concentration
Fernox F1	Refer to manufacturer's instructions
Nalco 77381	1 - 2 %
Sentinel X 100	1.1 %

Table 6 Corrosion inhibitors

- ▶ System fluid pH must be maintained between 7 and 8.5 to prevent system damage.
- ▶ Use only untreated water to fill the system.
- ▶ Do not use TSP (tri-sodium phosphate).
- ▶ Do not use fill water treated with salt bedding type exchangers (ion exchanger).
- ▶ Never introduce non-approved boiler treatment or similar additives.
- ▶ Only use fill water with a hardness below 7 grains.
- ▶ Filling with chlorinated water is acceptable if chlorine levels are below 100 ppm.
- ▶ Do not use inhibitors or other additives unless listed in this document.
- ▶ Consult a local water treatment specialist for recommendations if any of the above is outside the stated ranges.
- ▶ When using oxygen permeable PEX, the system must be separated from the boiler by a heat exchanger.
- ▶ A correctly sized and working expansion vessel must be installed.
- ▶ Do not exceed the maximum permissible flow rate through the boiler. Excessive flow can cause erosion damage to the heat exchanger.
- ▶ **Eliminate System Leaks**
Continuous addition of make-up water will constantly add oxygen to the system and lead to corrosion. All system leaks must be repaired.

Boiler sealer

This boiler is not approved for use with boiler sealer.

LPG

To protect the appliance against high pressure (ANSI/Z223.1/NFPA54 (National fuel gas code) or CAN/CSA B 149.1 (Natural Gas and Propane installation code)):

- ▶ Install a pressure regulator with a safety valve.

6.1.2 Other important information

- The installation of this boiler must comply with all national and local code and regulations.
- Only operate this boiler with the combined air/flue system specifically designed and approved for it.
- Only use approved venting systems per the manufacturer's instructions.
- Do not dispose of untreated boiler condensate in septic systems.
- Inspect the sewer pipes for suitability before disposing of untreated boiler condensate into them.

- Verify with the local authority that disposing of untreated boiler condensate into public sewer systems is permitted.

6.2 Comparing the size of the integrated expansion vessel (KWB-3A boiler only)

The following diagrams allow verifying that the integrated expansion vessel has sufficient capacity for the intended application, or if an additional expansion vessel is needed (not for radiant floor heating).

The following standard conditions were used:

- Pre-charge volume 20% of the rated volume in the expansion vessel
- Differential to the safety valve of 7.25 psi (0.5 bar)
- Pre-charge pressure of the expansion vessel equal to the static system height above the boiler
- Maximum operating pressure: 30 psi (2.07 bar)

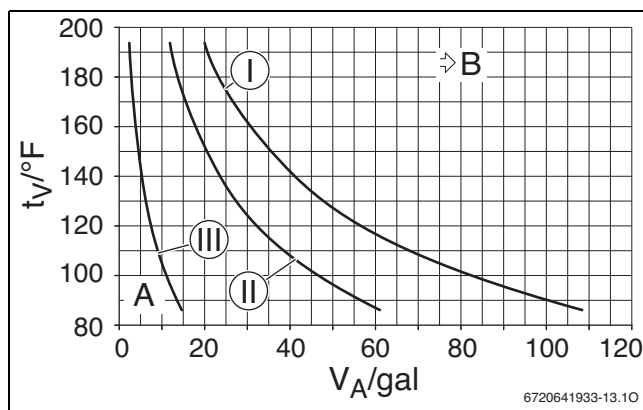

Fig. 16 Operating capacity of the expansion vessel in °F and gallons

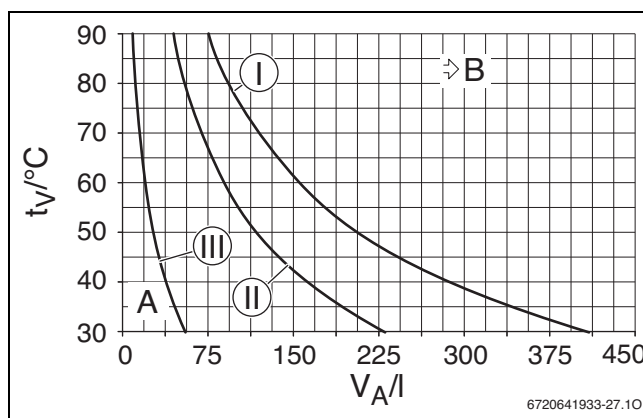

Fig. 17 Operating capacity of the expansion vessel in °C and liters

Key to Fig. 16 and Fig. 17:

- [I] Pre-charge pressure 7.25 psi (0.5 bar) (default setting)
- [II] Pre-charge pressure 10.9 psi (0.75 bar)
- [III] Pre-charge pressure 14.5 psi (1.0 bar)
- t_V Supply temperature in °F (°C)
- V_A System capacity in gallons (liters)
- A Within operating capacity of the expansion vessel (left of the relevant curve)
- B Additional expansion vessel required (right of the relevant curve)
- ▶ If results are borderline: Determine precise vessel sizes.
- ▶ If the results are to the right of the curve: Install additional expansion vessel.

6.3 KBR..-3A appliances (heating boilers): Selecting an expansion vessel

External expansion vessel

- Determine size of the expansion vessel.

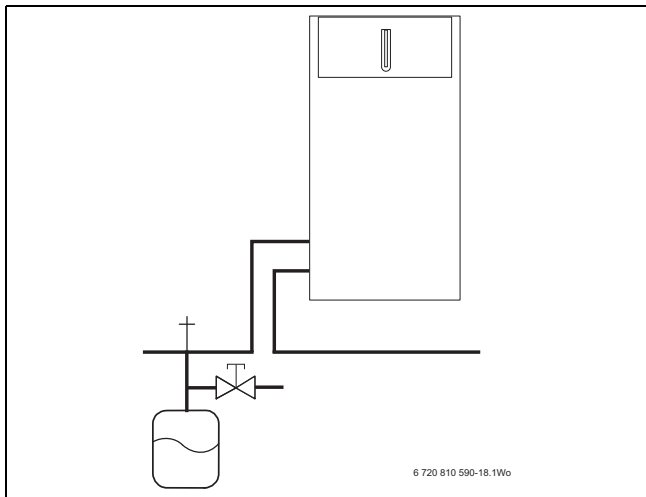

Fig. 18 Sample installation - expansion vessel

6.4 Selecting the installation location

Installation location requirements

Observe the current national and local codes and regulations.

- Observe country-specific requirements.
- Observe installation instructions of the venting system accessories and their clearances.

Combustion air

To avoid corrosion, keep the supply of combustion air free of corrosive substances; contained in solvents, paints, adhesives, propellants and domestic cleaning agents.

Industrial sources	
Chemical cleaning	Trichloroethylene, tetrachloroethylene, fluorinated hydrocarbons
Degreasing bath	Perchloroethylene, trichloroethylene, methylchloroform
Printing shops	Trichloroethylene
Hair salons	Aerosol propellants, hydrocarbons containing fluorine and chlorine (difluorodichloromethane)
Household sources	
Cleaning and degreasing agents	Perchloroethylene, methylchloroform, trichloroethylene, methylene chloride, carbon tetrachloride, hydrochloric acid
Workshop	
Solvents and thinners	Various chlorinated hydrocarbons
Aerosols	Chlorofluorinated hydrocarbons (difluorodichloromethane)

Table 7 Corrosive materials

Surface temperature

The max. surface temperature of this appliance is below 185 °F (85 °C). According to ANSI/Z223.1/NFPA43 (National fuel gas code) and CAN/CGA B 149.1 (Natural Gas and Propane installation code), the appliance is approved for zero clearance to combustibles. For servicing a clearance of 4" (102 mm) is recommended.

6.5 Low Loss Header (LLH) utilization

A Low Loss Header is primarily used on systems that require higher flow rate (gpm) requirements that exceed the flow rate (gpm) of the low mass heat exchanger. Typically systems that require additional zone pumps that are external to the appliance or exceed the single zone limitation of 4.5 gpm would require the low loss header.

A Low Loss Header is used to achieve hydraulic separation between the appliance and system piping.

If the heating system is a single zone and has no additional circulators other than its integrated pump, no modification of the LLH manifold is required.

If the heating system has additional circulators (for example multiple zones of panel radiator or baseboard heat) then the LLH plunger must be removed to allow the hydraulic separation of the appliance from the system.

This allows the appliance to continue satisfying the demands of the heating system when high system flow rates are expected.

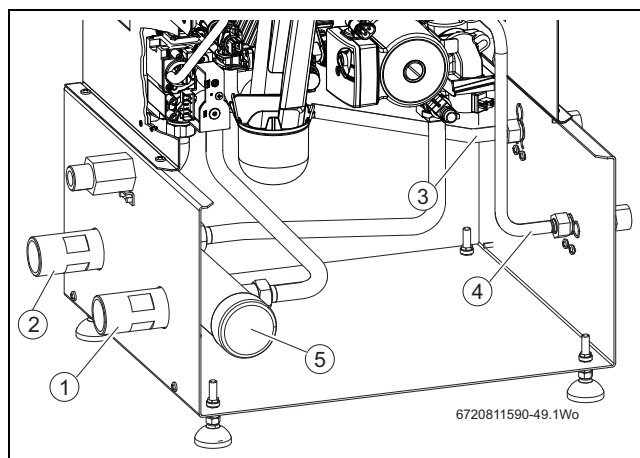

Fig. 19

- [1] Central heating supply
- [2] Central heating return
- [3] Domestic hot water outlet
- [4] Domestic cold water inlet
- [5] Low Loss Header

6.5.1 To utilize the LLH

- Switch off and isolate the boiler
 - Drain the boiler
 - Remove front panel
 - Locate the LLH at the left-hand side of the lower section of the boiler
1. Unscrew the cap [a] from the body of the LLH [c]
 - This will break the label across the cap and body indicating that the LLH has been employed
 2. Withdraw the cap [a] and plunger assembly [b]
 3. Unscrew the plunger assembly [b] from the cap [a],
 4. Set the plunger assembly [b] aside
 5. Re-fit the cap [a] without the plunger assembly [b]
 6. Tighten the cap [a] and ensure it is secure.

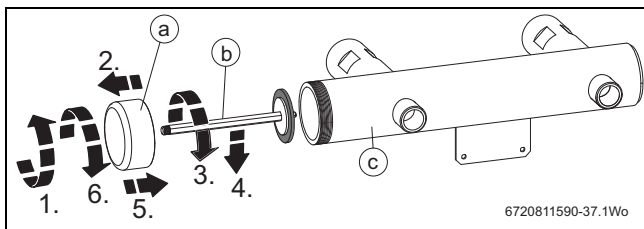

Fig. 20 Utilizing the LLH

6.6 Locating the appliance

NOTICE: Residue, metal shavings, and contaminants in the piping can damage the appliance.

- ▶ Flush the piping thoroughly and completely to remove all residue.
- ▶ Follow the instructions with respect to water quality (→ Chapter 6.1, page 30).

- ▶ Remove packaging, observing all notes and symbols.
- ▶ On the rating plate, check the identification of the target country and suitability for the gas type supplied by the local gas utility company (→ page 8).

Removing the cover

To remove the cover:

- ▶ Pull the front panel towards you from the top right and left edge to release the ball catches [1] from their retainers [2]
- ▶ Lift the front panel off the lower mounts [3] and place in a safe location away from the work area

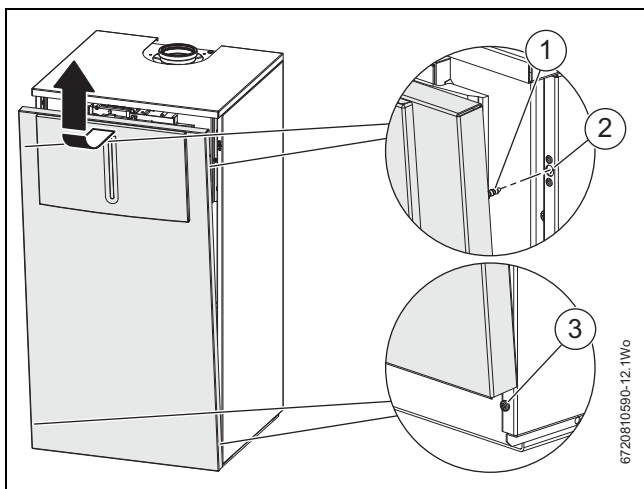

Fig. 21 Remove the cover

6.6.1 Positioning the appliance

The boiler must be adjusted to be level. This ensures air can escape from the heat exchanger and condensate drains freely.

NOTICE: Damage caused by insufficient load bearing or unsuitability of the boiler room floor

- ▶ Ensure the floor area is suitable for installing a boiler and can take the “wet weight” of the appliance.

NOTICE: Damaged caused by mechanical strain on the hydraulic and flue gas connections when adjusting the position of the appliance.

- ▶ Do not apply any strain the connections when adjusting the boiler position

- ▶ Place boiler in its final location
- ▶ Release the locknuts on the boiler feet
- ▶ Adjust the boiler feet until the boiler is level vertically and horizontally, check using a spirit level
- ▶ Secure in position with the locknuts

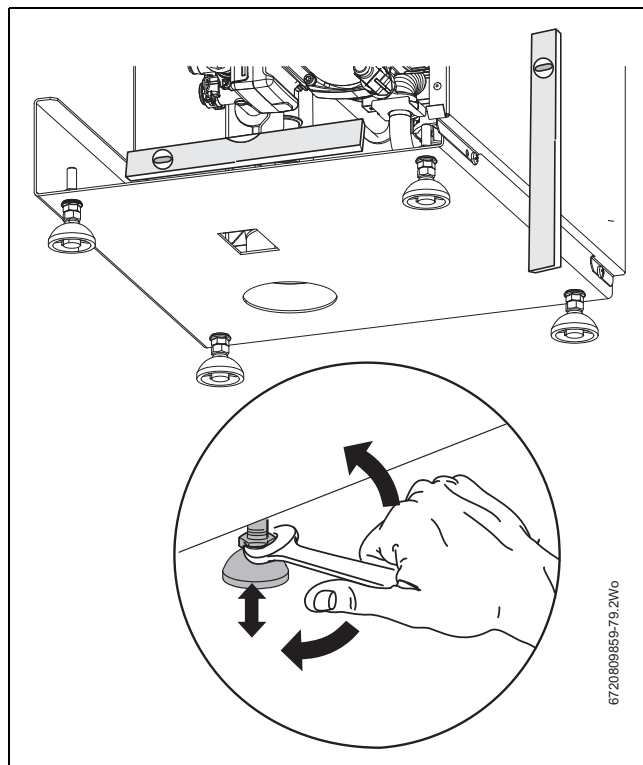

Fig. 22 Levelling the boiler

6.7 Installing a low water cut off (LWCO)

The boiler is equipped with a dedicated port for installation of a LWCO device on the supply pipe on the back of the boiler cabinet. This location represents the minimum water level for safe operation of the boiler.

The LWCO device must be specified for an ambient temperature of 176 °F (80 °C) and a water temperature of 250 °F (121 °C).

The following LWCO is approved with the boiler:

- Hydrolevel Safgard 1100

The device is available at most Bosch wholesalers. It requires an external 24VAC minimum 20VA transformer provided on site.



If other LWCO devices are to be used, they must be installed external to the boiler.

- ▶ Disconnect the boiler from power by shutting off the emergency switch or disengaging the heating system circuit breaker.
- ▶ Drain the boiler.
 1. Remove the safety clip from the dummy plug in the supply pipe.
 2. Pull off the dummy plug and place with the boiler documentation.
- ▶ Ensure the O-ring remains in place on the pipe.
- ▶ Lubricate the O-ring.

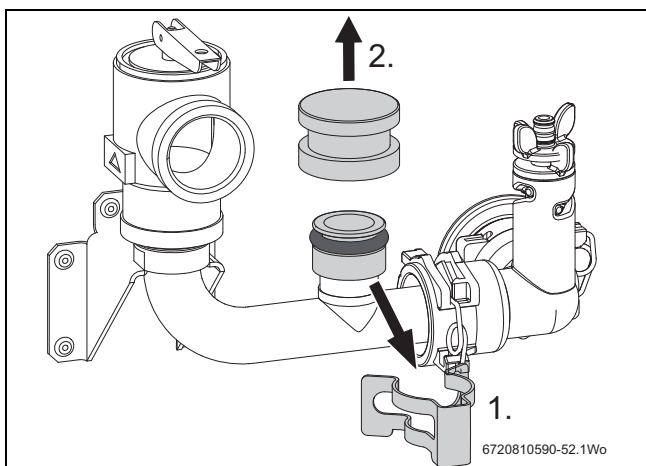

Fig. 23 Installing a LWCO device - removing dummy plug

- ▶ Screw the LWCO as far as possible into LWCO adapter located in the boiler accessory kit. Follow the Hydrolevel Safgard 1100 instructions.

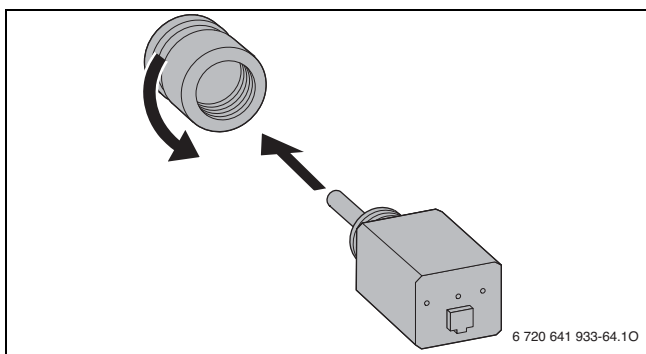

Fig. 24 Installing a LWCO device - LWCO adapter

1. Push the adapter with the LWCO onto the pipe
2. Secure with the clip

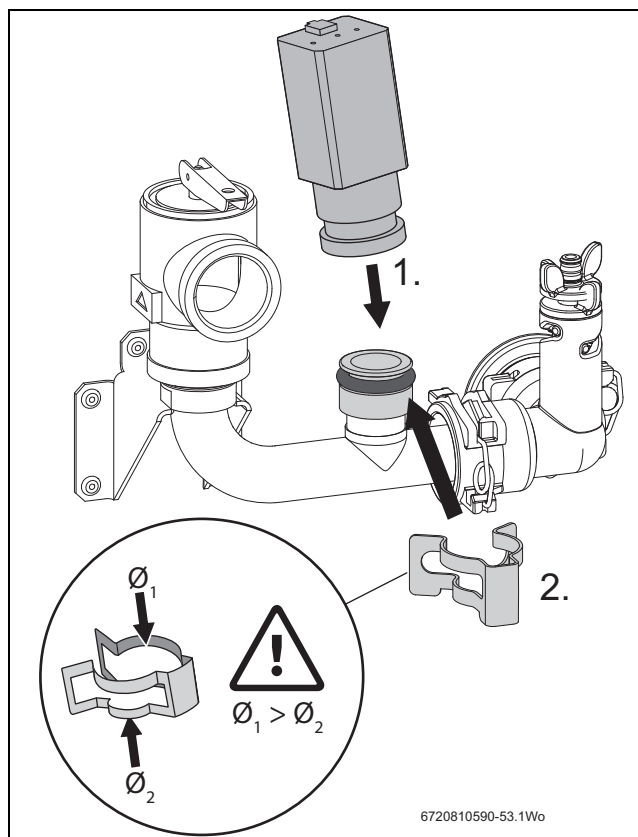

Fig. 25 Installing a LWCO device – securing with a clip

- ▶ Connect the wires of the LWCO (→ chapter 7.4, page 47).



The LWCO is positioned upright for technical reasons. Tests have shown that all air will be bled from the pipe during commissioning and full functionality is established.



If fault **d3** is displayed when commissioning the boiler, purge the boiler properly and check the boiler water pressure.

6.8 Connecting flue gas accessories

Optional vent systems are:

- Twin pipe PVC / CPVC 2" / 3"
- Twin pipe PP 2" (50mm) / 3" (80 mm)
(M&G Duravent PolyPro and Centrotherm InnoFlue)
- Concentric PP 3" / 5" (80/125 mm) (Bosch)

Using the **twin pipe adaptor**:



The twin pipe adaptor is supplied with the boiler kit as standard and is certified as a part of the vent system.

- ▶ Peel the backing of the gasket [1] and attach to the underside of the vent flange so that the holes line up [2]
- ▶ Remove three screws from the top of the appliance, align the vent flange to the open screw holes then secure the vent flange with the three screws that were just removed or the three screws provided.

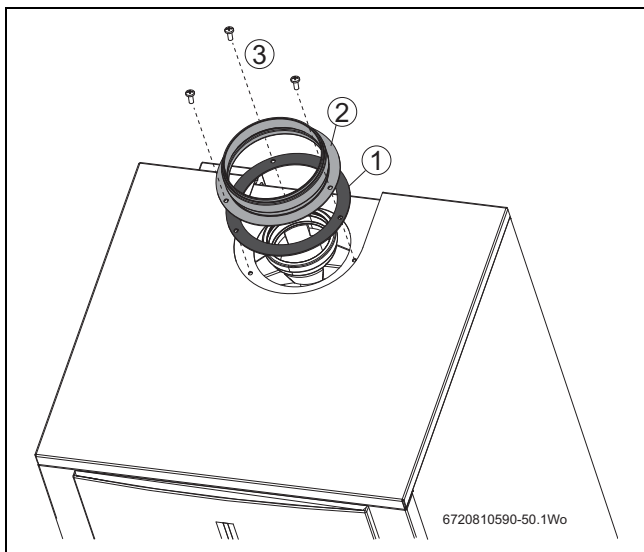

Fig. 26 Attaching the vent flange and gasket

- [1] Gasket
- [2] Vent flange
- [3] Screws

► Insert the flue gas adapter as far as it will go into the vent flange and align it.

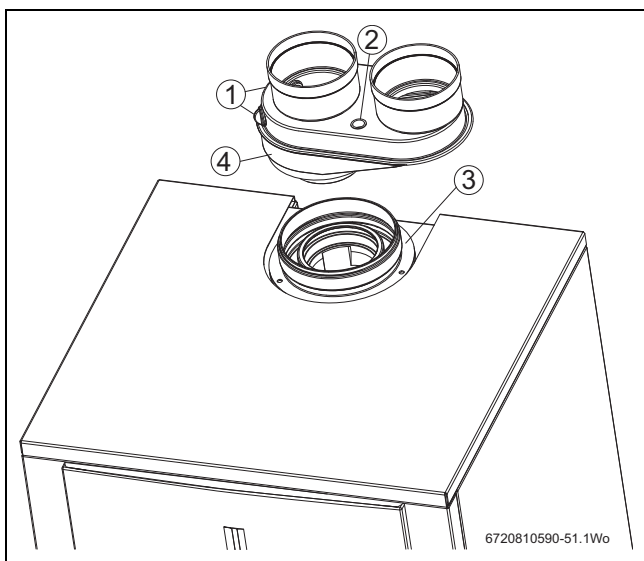

Fig. 27 Flue gas adapter

- [1] Combustion air test port
- [2] Flue gas test ports
- [3] Flue gas adapter
- [4] Vent flange

► Tighten the screws.



To avoid premature wear of the gaskets DO NOT use lubricants.

Using **open venting**:

► Use basket on the air intake.

Using **concentric venting system**:



As an alternative to twin pipe venting, a purposely designed and built telescopic concentric vent kit can be obtained as an accessory from Bosch Thermotechnology for a horizontal direct vent wall termination. This vent system can be used for vent lengths of 2 feet to 3 feet (610 mm to 915 mm).

For more details on connecting the flue system, refer to the installation instructions for the flue kit.

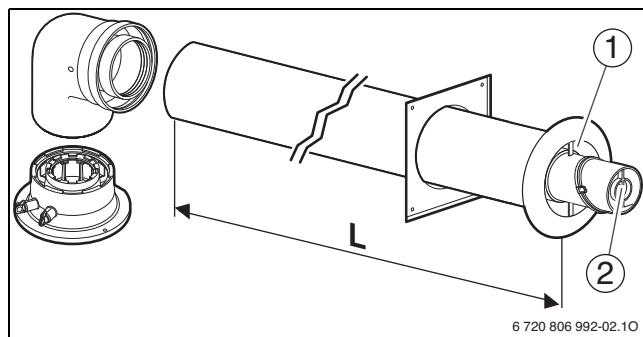

Fig. 28 Horizontal venting system (telescopic concentric vent kit)

- [1] Intake
- [2] Exhaust
- L 2 feet to 3 feet (610 mm to 915 mm)

► Install the concentric vent adaptor with the screws enclosed.

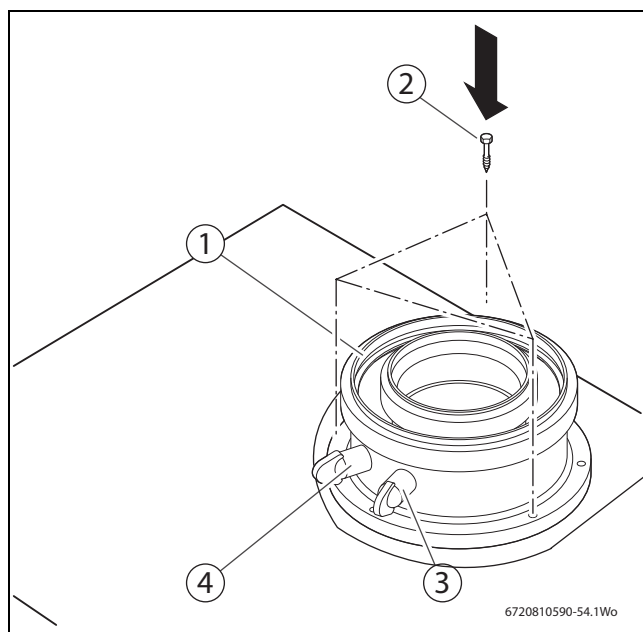

Fig. 29 Installing the concentric vent adaptor

- [1] Concentric vent adaptor
- [2] Screws
- [3] Combustion air test port
- [4] Flue gas test port

6.8.1 Installation of the exhaust and air intake system



DANGER: Carbon Monoxide poisoning

Improper venting of the Greenstar boiler can result in excessive levels of carbon monoxide which can result in severe personal injury or death.

- ▶ The boiler must be vented in accordance with the “Venting of Equipment” section of the latest edition of ANSI Z 223.1 / NFPA 54 Natural Fuel Gas Code and/or the “Venting systems and air supply for appliances” section of the latest version of CAN/CGA B149.1 Natural Gas and Propane Installation Code in Canada and in accordance with all applicable local building codes.



DANGER: Flue connections

Incorrectly fitted flue connections can lead to carbon monoxide escaping into the boiler room.

- ▶ Ensure that the flue pipes and seals are not damaged.
- ▶ Use only sealing compounds (primer and glue) approved with the vent material.
- ▶ Never install a barometric or a thermally controlled vent damper with this boiler.
- ▶ Connect only one boiler to each flue system.
- ▶ Do not route the flue system piping through or inside another duct that is used for exhausting air or other flue gases.
- ▶ The condensate trap must be primed at all times. Failure to do so may allow combustion gases to escape into boiler room.
- ▶ External insulation on plastic vent pipe is prohibited.

NOTICE: Vent connectors

- ▶ Vent connectors serving appliances vented by natural draft shall not be connected to any portion of mechanical draft systems operating under positive pressure.

NOTICE: Burner damage!

- ▶ Avoid drawing in combustion air excessively loaded with dust or airborne particles.



To avoid moisture and frost build-up and to maintain clearances to openings on adjacent homes, 45° and 90° elbows or tees may be attached to the end of the vent termination pipe to direct exhaust plumes away from the adjacent structure. The total allowable vent length, maximum number of elbows and distance to air intake restrictions must be adhered to.



Consult local and state codes pertaining to special building code and fire department requirements. Adhere to national code requirements.



Observe the listed maximum lengths of vent system, which are boiler model dependent (→ chapter 6.8.3).

Direct vent installations (sealed combustion)

For direct vent applications all applicable items below must be met.

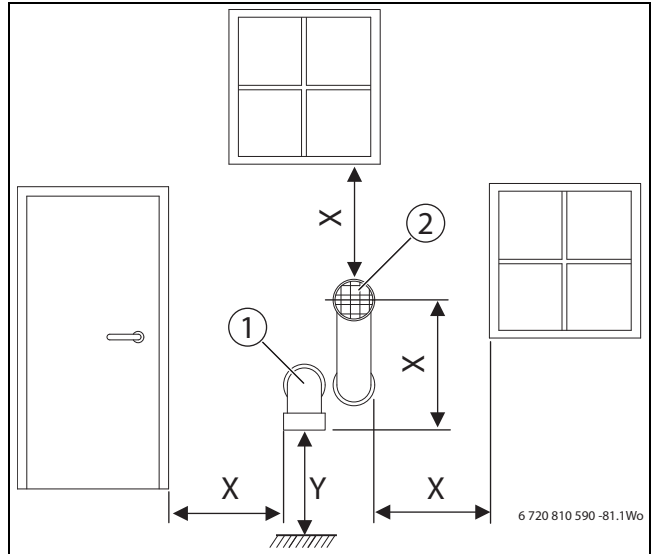

Fig. 30 Vent & combustion air pipe position of a sealed combustion system

[1] Intake

[2] Exhaust

X At least 1 foot (305 mm)

Y At least 1 foot (305 mm) above grade, roof or anticipated snow line

The termination shall terminate at least 1 foot (305 mm) below, 1 foot (305 mm) horizontally from or 1 foot (305 mm) above any door, window or gravity air inlet into any building (→ fig. 31 [2], [X₁], [X₃], page 39).

If multiple boilers are installed in a row, allow at least 1 foot (305 mm) clearance between the vent termination of one and the combustion air intake of the other.

Vent termination must be at least 1 foot (305 mm) above grade, anticipated snow line or roof surface (Canada 1-1/2 feet (457 mm) minimum) (→ fig. 31 [Y_A], page 39).

Vent termination must be at least 7 feet (2135 mm) above a public walkway (→ fig. 31 [X₅], page 39). Ensure that condensate spilling from the termination does not create a hazard or a nuisance.

Vent termination must be 3 feet (915 mm) above any forced air intake within 10 feet (3050 mm) (→ fig. 31 [1], [Y_B], page 39).

Do not extend exposed vent pipe outside the building beyond recommended distance. Condensate could freeze and block vent pipe. Vent should terminate at least 3 feet (915 mm) away from adjacent walls, inside corners and 5 feet (1525 mm) below roof overhang (→ fig. 31 [X₂], [X₄], page 39).

It is not recommended to terminate vent above any door or window, condensate can freeze causing ice formations.

Do not use chimney as a raceway if another boiler or fireplace is vented into or through chimney.

All PVC/CPVC vent pipes must be glued, except for the flue gas adapter-pipe connection.



The exhaust pipe must be properly supported and pitched a minimum of ¼” (6.35 mm) per foot back to the boiler. This allows the condensate to properly drain.

NOTICE: Combustion air and vent pipe materials for KBR42-3A & KWB42-3A. Heat damage to 2" PVC pipes.
 ► KBR42-3A & KWB42-3A appliances combustion air and vent pipes, use 2" CPVC-pipes or 3" pipes.

All PP/PVC/CPVC combustion air and vent pipe materials and fittings must comply with the following and must be UL approved venting material:

Material	Item	United states	Canada	KBR16-3	KBR21-3	KBR28-3	KBR35-3	KBR42-3	KWB28-3	KWB35-3	KWB42-3	
PVC schedule 40, 80	2" (50 mm) Vent or air pipe and fitting	ANSI/ASTM D1785	BH Gas venting systems, ULC S636 ¹⁾ , Class IIA - PVC, Class IIB - CPVC, Class IIC - Polypropylene (certified to ULC S636)	X	X	X	X		X	X		
PVC-DWV		ANSI/ASTM D2665		X	X	X	X		X	X		
CPVC schedule 40, 80		ANSI/ASTM F441		X	X	X	X	X	X	X	X	
PVC schedule 40, 80	3" (76 mm) Vent or air pipe and fitting	ANSI/ASTM D1785		X	X	X	X	X	X	X	X	
PVC-DWV		ANSI/ASTM D2665		X	X	X	X	X	X	X	X	
CPVC schedule 40, 80		ANSI/ASTM F441		X	X	X	X	X	X	X	X	
PP rigid venting	2" (50 mm) vent or air pipe M&G Duravent PolyPro and Centrotherm InnoFlue	ANSI Cat IV			X	X	X	X		X	X	
PP rigid venting	3" (80 mm) vent or air pipe M&G Duravent PolyPro and Centrotherm InnoFlue	ANSI Cat IV			X	X	X	X	X	X	X	X
PP rigid venting	3"/5" (80/125 mm) concentric Bosch (manufactured by M&G Duravent)	ANSI Cat IV			X	X	X	X	X	X	X	X
PP rigid venting		ANSI Cat IV			X	X	X	X	X	X	X	X
PP Flex	Same as 3" PP above	ANSI Cat IV		X	X	X	X	X	X	X	X	
PP Flex	Same as 2" PP above	ANSI Cat IV		X	X	X	X	X	X	X	X	
PVC	Pipe cement/primer	ANSI/ASTM D2564		X	X	X	X	X	X	X	X	
CPVC		ANSI/ASTM F493		X	X	X	X	X	X	X	X	

Table 8 Materials for pipe

1) Components of the certified vent systems must not be interchanged with other vent systems or unlisted pipe fittings. Plastic components, and specified primers and glues of the certified vent system must be from a single system manufacturer and not intermixed with other system manufacturer's vent system parts.

For installations in Canada, field supplied [plastic vent piping must comply with CAN/CGA B149.1 (latest edition) and be certified to the Standard for Type BH Gas Venting systems. ULC S636 Components of this listed system shall not be interchanged with other vent systems or unlisted pipe/fittings. All plastic components and specified primers and glues of certified vent systems must be from a single manufacturer and not intermingled with other system manufacturer's vent system parts.

The supplied vent connector and separate available vent termination are certified as a part of the Greenstar Boiler

Roof terminals	Material	Supplier	Part number
Ø 3" / Ø 5" (Ø 76/125mm)	concentric PVC	IPEX System 636	196006
Ø 3" / Ø 5" (Ø 76/125mm)	concentric CPVC	IPEX System 636	197009
Ø 3" / Ø 5" (Ø 80/125mm)	concentric PP	M&G Duravent PolyPro and Centrotherm InnoFlue.	3PPS-VK (-TC) (M&G Duravent) or ICRT3539 (Centrotherm)
Ø 3" (Ø 80mm)	PolyPro Flex Chimney Cap (PP)	M&G Duravent PolyPro Centrotherm InnoFlue	3PPS-FCT ISCP03
with base support	PolyPro Support elbow Base Support + SW to Flex Coupler	M&G Duravent PolyPro Centrotherm InnoFlue	3PPS-SE90X ISBS0387 + IFSFC03
Ø 2" (Ø 50mm)	PolyPro Flex Chimney Cap (PP)	M&G Duravent PolyPro Centrotherm InnoFlue	2PPS-FCT ISCP02
with base support	PolyPro Support elbow Base Support + SW to Flex Coupler	M&G Duravent PolyPro Centrotherm InnoFlue	2PPS-SE90X ISBS0287 + IFSFC02

Table 9 Roof terminals

Wall terminals	Flue System / Materials	Supplier	Part number
Ø 3" (Ø 76 mm)	parallel stainless steel	Flex-L	46546901
90°-elbow with inlet screen	PVC (elbow) stainless steel (screen)	IPEX (elbow) Langly Wire (screen)	ULC-S636 approval (elbow) L2594 (screen)
Ø 3" (Ø 76 mm) twin pipe termination	PP	M&G Duravent PolyPro	3PPS-HTP
Ø 3" (Ø 76 mm) single pipe termination	PP	M&G Duravent PolyPro	3PPS-HST
Ø 3" / Ø 5" (Ø 80/125 mm) Bosch Greenstar Horizontal Telescopic Terminal Kit	PP	Bosch (manufactured by M&G Duravent)	7738003218

Table 10 Wall terminals

NOTICE:

- ▶ DO NOT use cellular core pipe.
- ▶ DO NOT use PVC when using anti-freeze in the primary circuit of the boiler. Use CPVC, PP or stainless steel only!

NOTICE:

- ▶ Vent terminations must keep the following minimum clearances from electric meters, gas meters, regulators and relief equipment: 4 feet (1220 mm) [Canada 1830 mm] horizontally and in no case above and below, unless a horizontal distance of 4 feet (1220 mm) [Canada 1830 mm] is maintained.

NOTICE:

- ▶ For clearances not specified in ANSI Z223.1 / NFPA 54 or CSA B149.1
Clearance in accordance with local installation codes and the requirements of the gas supplier including the authority having jurisdiction.

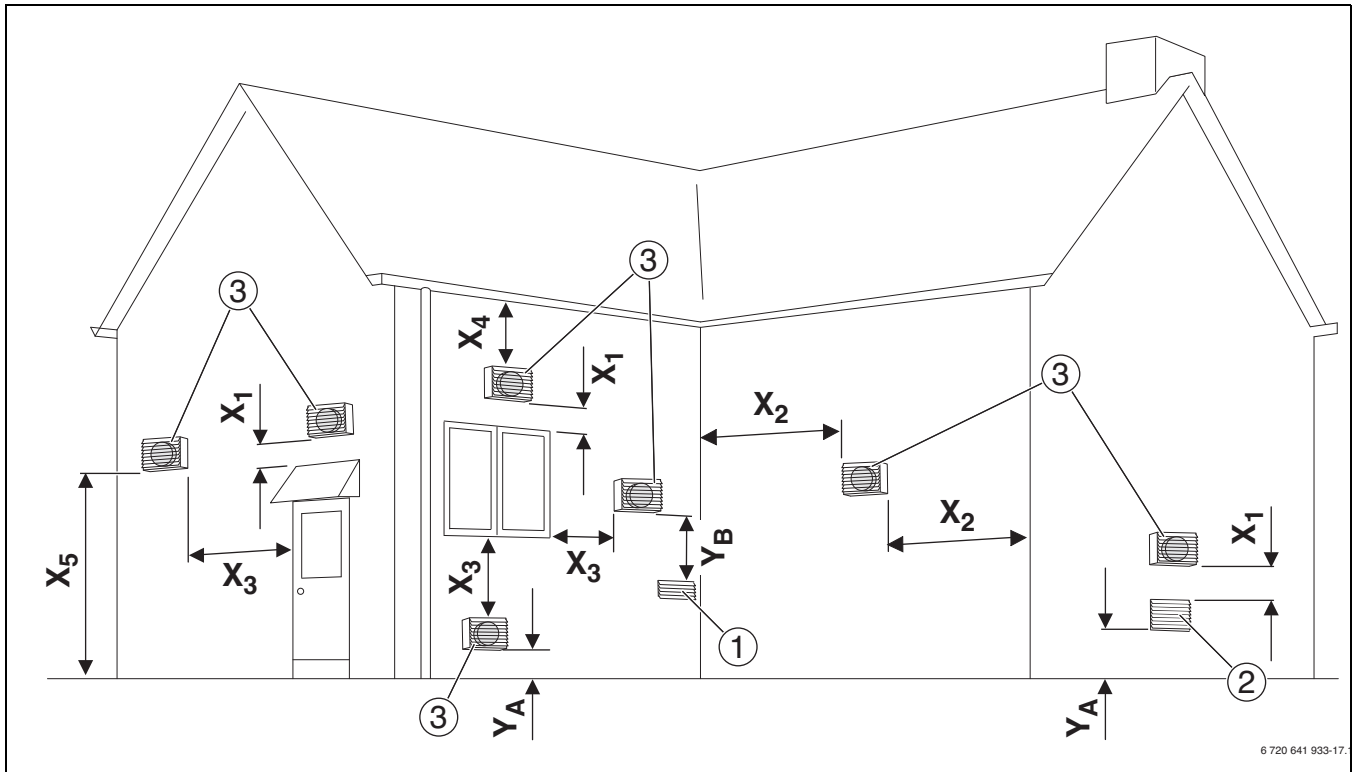

Fig. 31 Vent and combustion air pipe position

Direct vent (sealed combustion):

- [1] Forced Air Inlet
- [2] Gravity Air Inlet
- [3] Exhaust terminal
- X₁ 1 foot (305 mm)
- X₂ See Note ¹⁾
- X₃ 1 foot (305 mm) **USA**
3 feet (915mm) **Canada** for models K...35-3A and K...42-3A
- X₄ See Note ¹⁾
- X₅ 7 feet (2135 mm) ²⁾
- Y_A At least 1 foot (305 mm) above grade or snow line
- Y_B Exhaust terminal must be at least:
3 feet (915 mm) above forced air inlet within 10 feet (3050 mm) horizontally - **USA**
6 feet (1830 mm) above forced air inlet - **Canada**

Fan assisted appliance (non-sealed combustion):

- [1] Forced Air Inlet
- [2] Gravity Air Inlet
- [3] Exhaust terminal
- X₁ 1 foot (305 mm)
- X₂ See Note ¹⁾
- X₃ 1 foot (305 mm) **USA**
3 feet (915mm) **Canada** for models K...35-3A and K...42-3A
- X₄ See Note ¹⁾
- X₅ 7 feet (2135 mm) above public walkway
- Y_A At least 1 foot (305 mm) above grade or snow line
- Y_B Exhaust terminal must be at least:
3 feet (915 mm) above forced air inlet within 10 feet (3050 mm) horizontally - **USA**
6 feet (1830 mm) above forced air inlet - **Canada**



Clearance in accordance with local installation codes and the requirements of the gas supplier including the authority having jurisdiction.

1) For Clearances not specified in ANSI Z223.1 / NFPA 54 or CSA B149.1
Clearance in accordance with local installation codes and the requirements of the gas supplier including the Authority having jurisdiction.

2) A vent shall not terminate directly above a sidewalk or paved driveway that is located between 2 single family dwellings and serves both dwellings.

6.8.2 Approved examples of horizontal and vertical venting installation

NOTICE:

- ▶ Place pipe supports every 5 feet (1525 mm) of horizontal and vertical run, beginning with support near boiler.
- ▶ The condensate must be disposed of in accordance with applicable rules.
- ▶ Periodic cleaning of the vent terminal and air-intake screens is mandatory.
- ▶ Avoid locating vent terminals near equipment or building features which can be subject to degradation from exhaust gases.
- ▶ If multiple boilers are installed in a row, allow at least 1 foot (305 mm) clearance between the vent termination of one and the combustion air intake of the other.

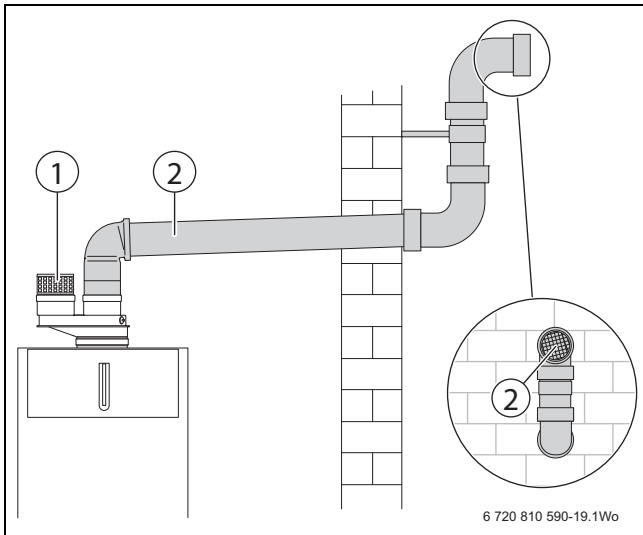

Fig. 32 Horizontal venting system (room air only)

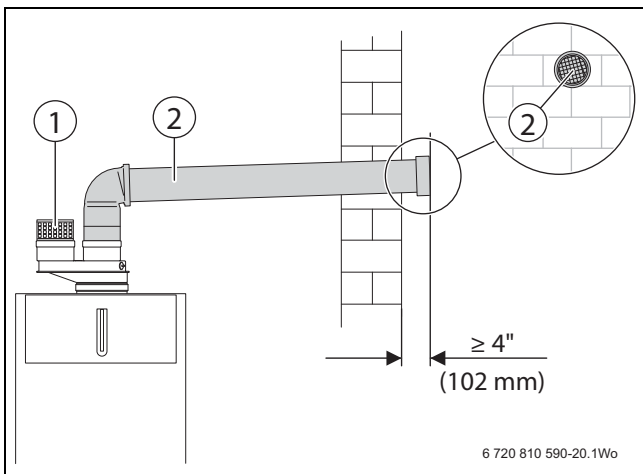

Fig. 33 Horizontal venting system (room air only)

Key to Fig. 32 and Fig. 33:

- [1] Intake
- [2] Exhaust

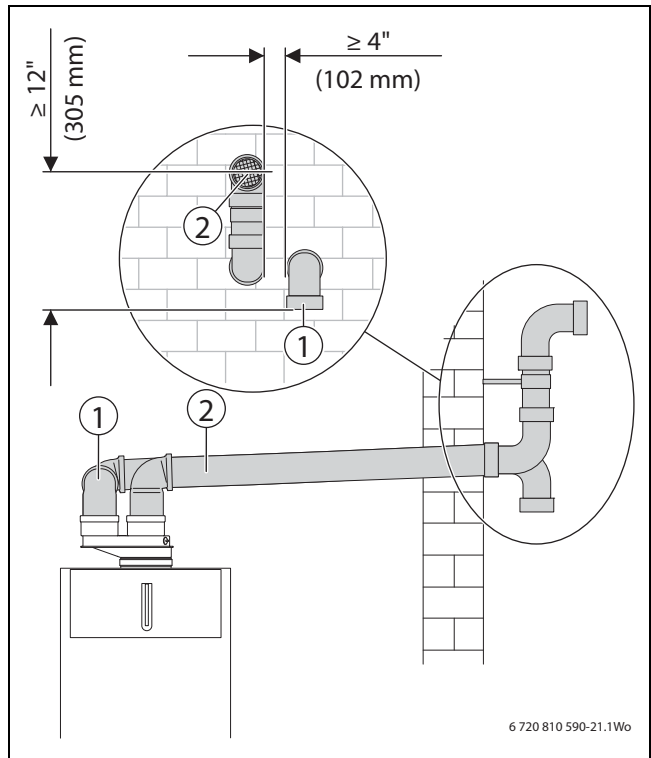

Fig. 34 Horizontal venting system (sealed combustion)

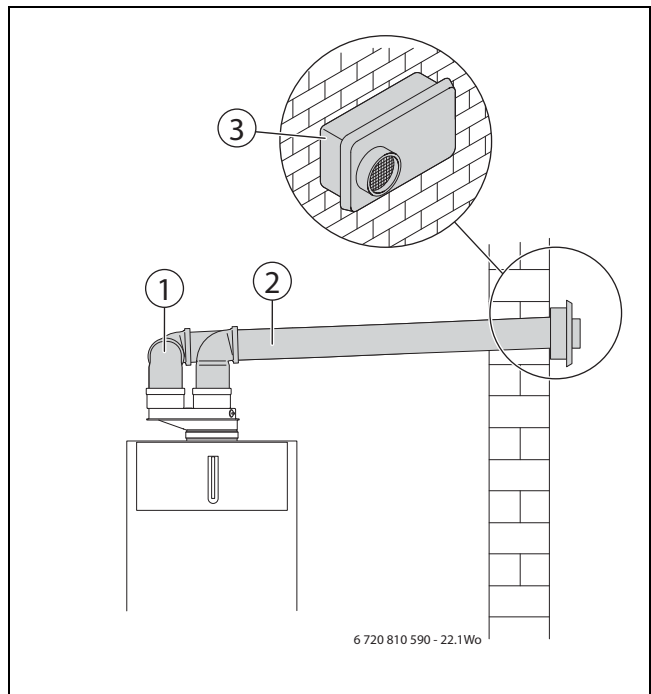
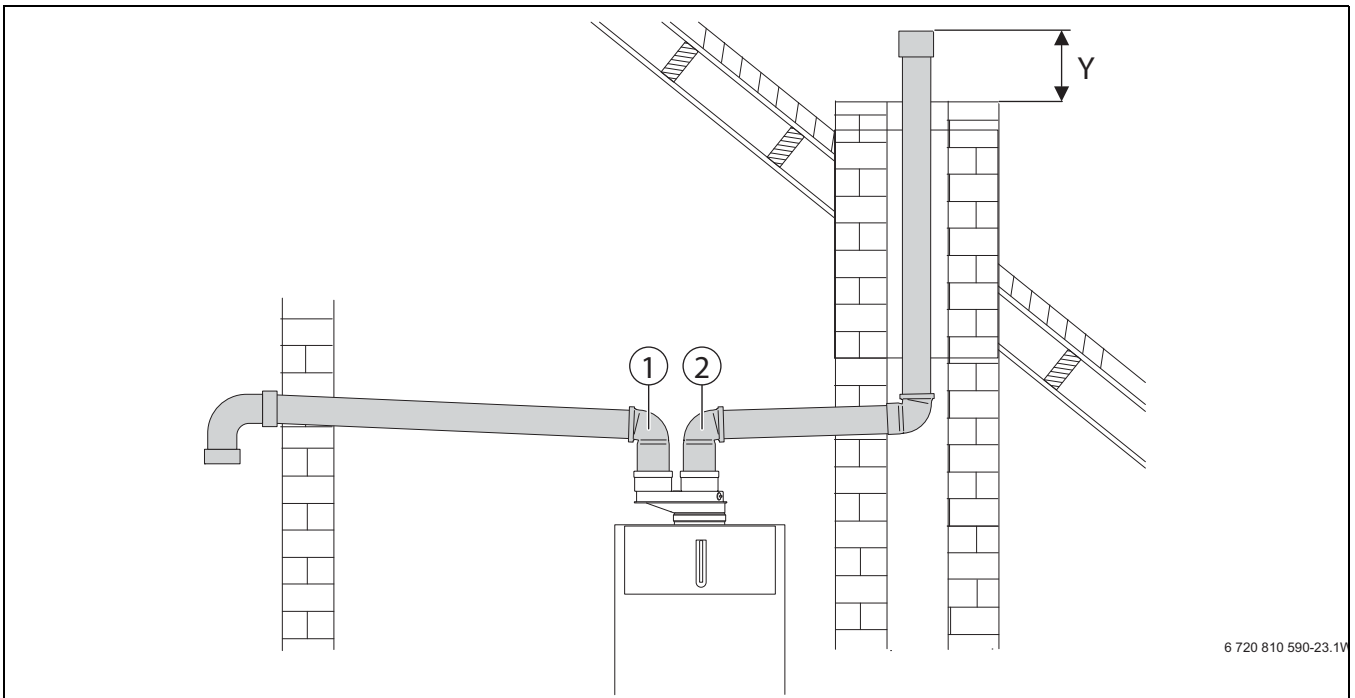

Fig. 35 Horizontal venting system (sealed combustion)

Key to Fig. 34 and Fig. 35:

- [1] Intake, behind exhaust
- [2] Exhaust
- [3] Wall termination



6 720 810 590-23.1V

Fig. 36 Vertical venting system (sealed combustion)

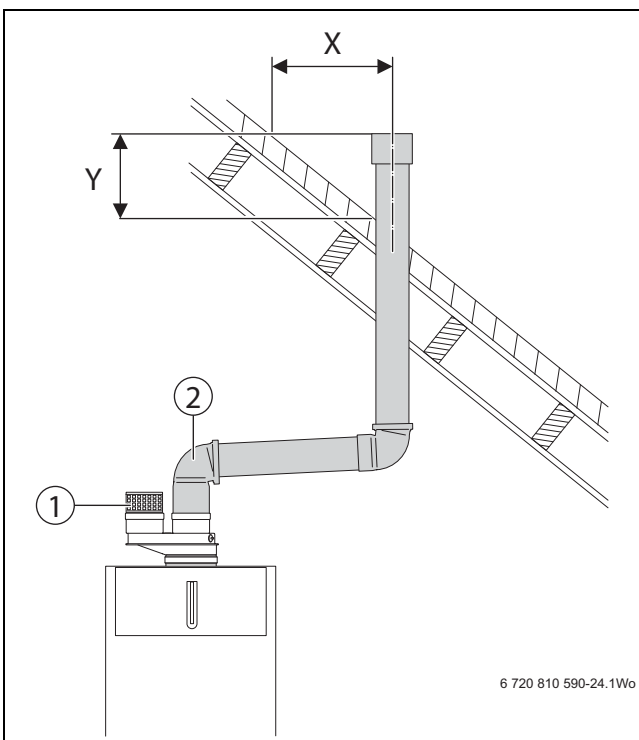

6 720 810 590-24.1Wo

Fig. 37 Vertical venting system (room air only)

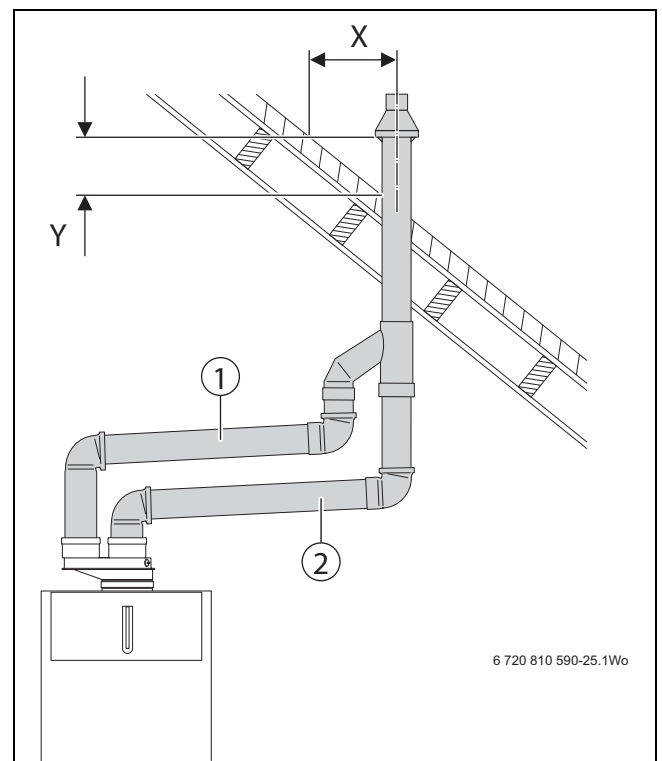

6 720 810 590-25.1Wo

Fig. 38 Vertical venting system (sealed combustion)

Key to Fig. 36, Fig. 37 and Fig. 38:

- [1] Intake
- [2] Exhaust
- [3] Concentric termination
- X Greater than 12 inches (305 mm)
- Y 12 inches (305 mm) above maximum snow level or at least 24 inches (610 mm) whichever is greater

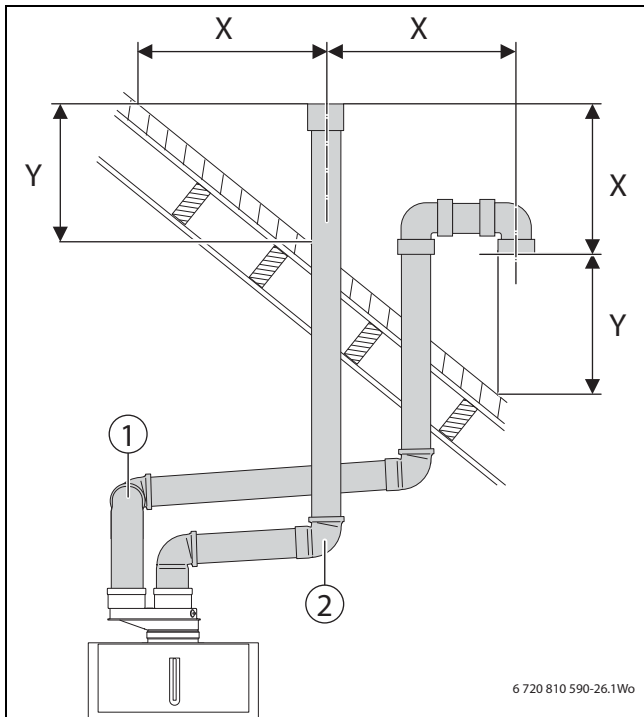

Fig. 39 Vertical venting system (sealed combustion)

- [1] Intake
- [2] Exhaust
- X Greater than 12 inches (305 mm)
- Y 12 inches (305 mm) above maximum snow level or at least 24 inches (610 mm) whichever is greater



The transitions from rigid to corrugated pipe must conform to the S636 standard - Plastic vent pipe for gas fired appliances

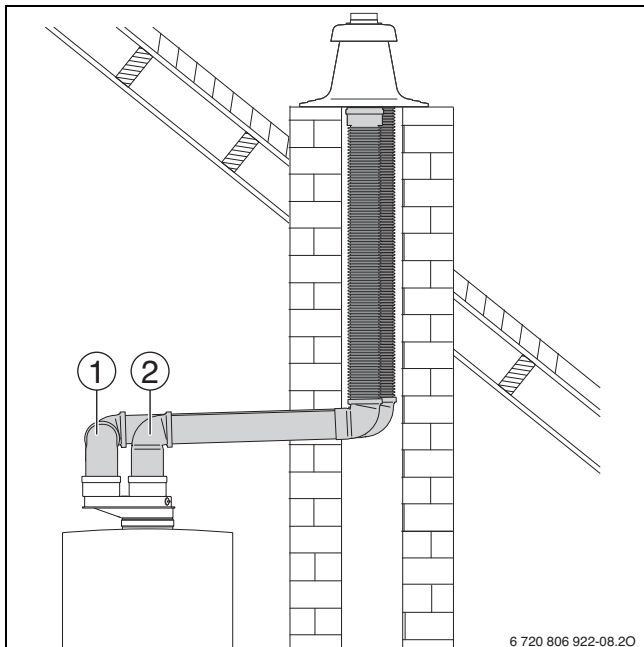

Fig. 40 PolyPro Flex Chimney Cap (PP) vertical venting system (sealed combustion)

- [1] Intake
- [2] Exhaust

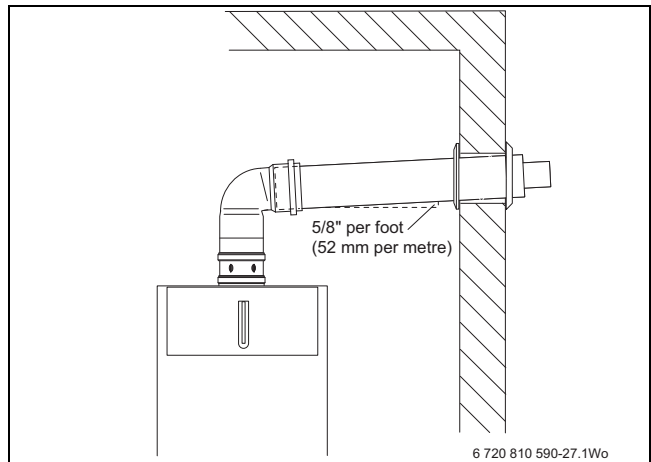

Fig. 41 Horizontal venting system (telescopic concentric vent kit)

6.8.3 Vent and combustion air pipe lengths



With Flex pipe the maximum length is reduced by 50% Flex pipe according to the suppliers instructions for use in the vertical part of the installation only.

3" (76 mm) Vent and combustion air pipe

For all installation situations and for all appliances the maximum vent and combustion air pipe length is 100 feet each, with no more than 8 elbows each.

2" (50 mm) Vent and combustion air pipe

The maximum combined vent and combustion air pipe length (→ tab. 11, 12 and 13) depend on the installation situation, the appliance type and the number of elbows used.



Flue runs must be one continuous diameter and the exhaust and inlet pipe must be of the same diameter. Any pipe diameter reductions must be made at the supplied adaptor or within 1 foot of the adaptor

Installations → Fig. 32, 33, 34, 36, 37 and 39

Separate terminations

2" PIPE	Maximum effective vent pipe length allowed for Ø 2" pipe	
	KBR16-3 KBR21-3	KBR35-3 KWB35-3
Number of 90° elbows used	KBR28-3 KWB28-3	KBR42-3 KWB42-3
1	81 ft (24.6 m)	65 ft (19.8 m)
2	76 ft (23.1 m)	57 ft (17.3 m)
3	71 ft (21.6 m)	48 ft (14.6 m)
4	66 ft (20.1 m)	40 ft (12.2 m)
5	61 ft (18.6 m)	32 ft (9.8 m)
6	56 ft (17.1 m)	23 ft (7.0 m)

Table 11 Vent and combustion air pipe lengths with 2" diameter and separate terminations

Installations → Fig. 35 Stainless steel wall termination		
2" PIPE	Maximum effective vent pipe length allowed for Ø 2" pipe	
	KBR16-3 KBR21-3 KBR28-3 KWB28-3	KBR35-3 KWB35-3 KBR42-3 KWB42-3
Number of 90° elbows used		
1	76 ft (23.1 m)	60 ft (18.3 m)
2	71 ft (21.6 m)	52 ft (15.9 m)
3	66 ft (20.1 m)	43 ft (13.1 m)
4	61 ft (18.6 m)	35 ft (10.7 m)
5	56 ft (17.1 m)	27 ft (8.2 m)
6	51 ft (15.6 m)	18 ft (5.5 m)

Table 12 Vent and combustion air pipe lengths with 2" diameter and the stainless steel wall termination

Installations → Fig. 38 Concentric termination		
2" PIPE	Maximum effective vent pipe length allowed for Ø 2" pipe	
	KBR16-3 KBR21-3 KBR28-3 KWB28-3	KBR35-3 KWB35-3 KBR42-3 KWB42-3
Number of 90° elbows used		
1	66 ft (20.1 m)	47 ft (14.3 m)
2	61 ft (18.6 m)	38 ft (11.6 m)
3	56 ft (17.1 m)	30 ft (9.1 m)
4	51 ft (15.6 m)	22 ft (6.7 m)
5	46 ft (14.1 m)	13 ft (4.0 m)
6	41 ft (12.5 m)	5 ft (1.5 m)

Table 13 Vent and combustion air pipe lengths with 2" diameter and the concentric termination

Ø 3" / Ø 5" (Ø 80/125 mm) Concentric venting system

The maximum concentric pipe length (→ tab. 14) depends on the installation situation, the appliance type and the number of elbows used.

Installations → Fig. 41		
CONCENTRIC PIPE	Maximum straight vent pipe length allowed for Ø 3" / Ø 5" (Ø 80/125 mm) concentric pipe	
	KBR16-3 KBR21-3 KBR28-3 KWB28-3	KBR35-3 KWB35-3 KBR42-3 KWB42-3
Number of 90° elbows used		
1	50 ft (15.2 m)	44 ft (13.4 m)
2	44 ft (13.4 m)	38 ft (11.6 m)
3	38 ft (11.6 m)	32 ft (9.8 m)
4	32 ft (9.8 m)	26 ft (7.9 m)
5	26 ft (7.9 m)	20 ft (6.1 m)
6	20 ft (6.1 m)	14 ft (4.3 m)

Table 14 Pipe lengths with Ø 3" / Ø 5" (Ø 80/125 mm) diameter and termination

Fitting	Equivalent	
	ft	m
45° elbow	3	0.91
90° elbow	6	1.82

Table 15 Concentric pipe friction loss equivalent for fittings

Example:

- Model: **KBR28-3A**
- 90° elbows used: **2**
- 45° elbows used: **2**

Maximum straight vent pipe allowed: **38ft (11.6 m)**

6.9 Testing gas and water connections for leaks

NOTICE: System damage!

Pressure, control and safety equipment may be damaged by excessive pressure.

- ▶ When you carry out a leakage test, make sure that no pressure, control or safety equipment is installed that cannot be isolated from the test pressure.
- ▶ The boiler and its dedicated shutoff valve must be disconnected from the gas supply piping system during any pressure testing of that system at test pressures in excess of 14" W.C. (35 mbar).

Water connections

- ▶ Open the heating supply and return valves and fill the heating system.
- ▶ Check all connections for leakage (test pressure: Max. 30 psi (2.07 bar) on the pressure gauge).

Gas line

- ▶ Close the gas shutoff valve to protect the gas valve from damage.
- ▶ Check all connections for leakage (test pressure: Max. 60" W.C. (150 mbar)).
- ▶ Release pressure.

7 Making the electrical connections

7.1 General notes



DANGER: Risk of electric shock!

- ▶ Before working on the power supply (120 VAC), disconnect the boiler from the grid by shutting off the emergency shutoff switch or disengaging the heating system circuit breaker. Take measures to prevent accidental re-connection.
- ▶ It is not sufficient to simply shut off the controls.
- ▶ Observe all applicable electrical codes and regulations.

Electrical components must be installed by a trained and certified electrician and the installation must meet the National Electric Code as well as all applicable local codes and regulations.

The boiler must be properly electrically grounded in accordance with the requirements of the authority having jurisdiction or, in the absence of such requirements with the National Electrical Code, ANSI/NFPA 70 and/or the Canadian Electrical Code Part I, CSA C221.1, Electrical Code.



Provide a dedicated circuit breaker for the boiler and heating system rated at least 15A. All line voltage wiring must use at least AWG14 size cables.

All appliance modulation, control and safety components are tested and pre-wired for use.

Observe safety precautions and all rules and regulations required by local code and the National Electric Code.

Fuses

The appliance is protected with a fuse. It is located on the circuit board (→ Fig. 9, page 14).



Replacement fuses can be found on the back of the cover

Controls and modules

For installation and electrical connection of controls and modules, see the installation instructions of the accessory.

7.2 Electrical connections in the junction boxes

7.2.1 Access to junction boxes

All the electrical connections are available via the two installer junction boxes, either high voltage (120 VAC) and low voltage (<24V DC).

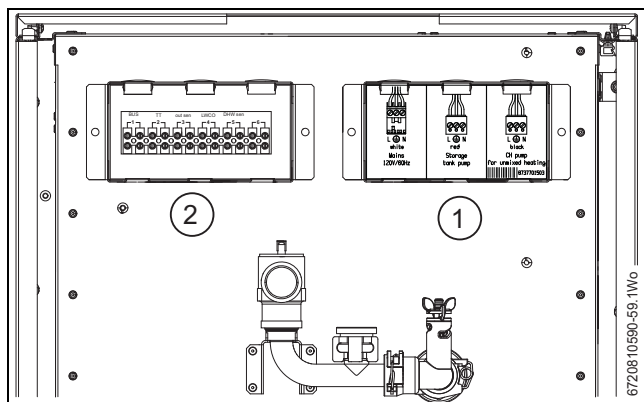

Fig. 42 Installer junction boxes with covers removed

- [1] High voltage junction box
- [2] Low voltage junction box

7.2.2 Connecting the BUS-system

Connect only Bosch room controls to the internal BUS of this boiler. For further details see the technical documentation of the BUS system components (e. g. CRC200 and CZM100).

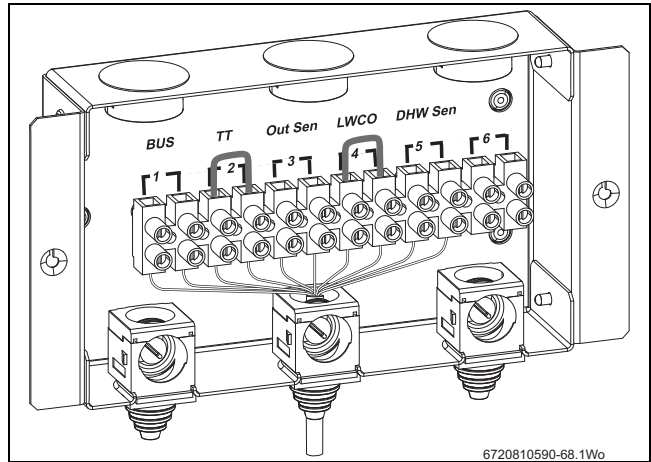

Fig. 43 Low voltage (LV) connections

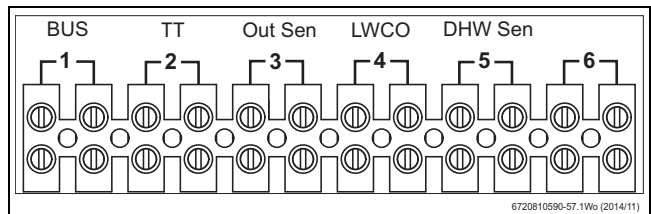

Fig. 44 Low voltage (LV) terminals (pre-wire links not shown)

- [1] BUS - BUS connection to programmer

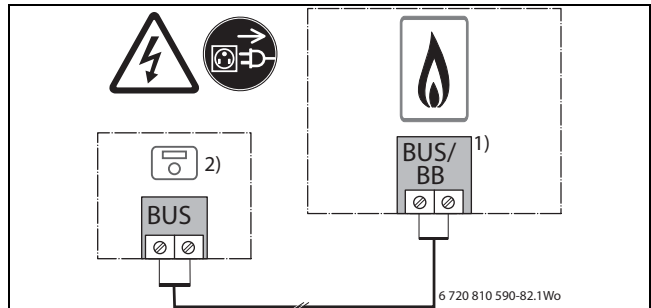

Fig. 45

- [1] Terminal at the boiler reads BUS or BB, both indicating connection of the 2-wired Bosch BUS system.
- [2] Bosch Controller.

7.2.3 High voltage junction box

The high voltage installer junction box provides connections for mains power, one system circulator pump and one DHW Tank Circulator pump.

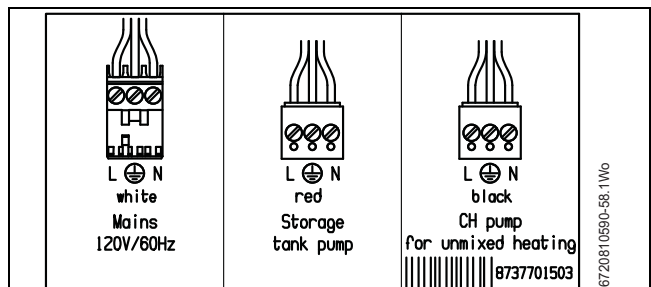

Fig. 46

7.2.4 Connecting an external heating zone pump or DHW recirculation pump

Without accessories the appliance offers the connection of one heating zone pump, one circulator of an unmixed heating circuit, or one DHW recirculation pump.

The pump used must have the following connection values: 120 VAC, max. 2 A.

- ▶ Route cable from pump to appliance.
- ▶ Insert cable into the junction box as shown in Fig. 48.
- ▶ Connect cable to **the black plug** according to Fig. 47.

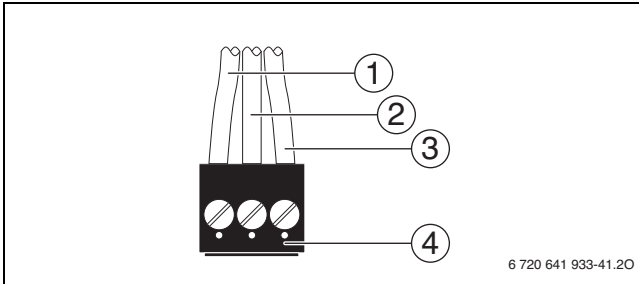

Fig. 47 Attach plug (external pump)

- [1] L (120 VAC, 60 Hz)
- [2] PE (GND, Ground)
- [3] N (Neutral)
- [4] Black plug (in the junction box upon delivery)

- ▶ Connect black plugs and insert grommet until stop.

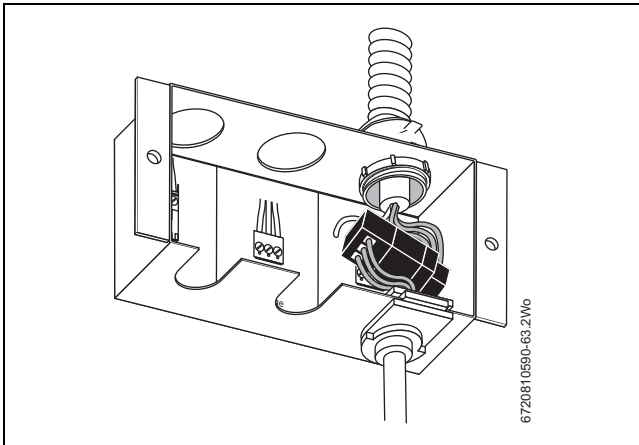

Fig. 48 Cable connected (external pump)

- ▶ Use service function 5.E, to set connection to **01** (DHW recirculation pump) (→ page 56)

-or-

- ▶ Use service function 5.E to set connection to **02** (external heating zone pump in an unmixed heating circuit) (→ page 56).

-or-

- ▶ Use service function 5.E to set connection to **03** (external heating pump) (→ page 56).



The DHW recirculation pump is controlled by the Bosch FW 200.

7.2.5 DHW tank loading pump or 3-way valve with spring return (only heating boiler KBR...3A)

The pump used must have the following connection values: 120 VAC, max. 2 A.

- ▶ Route cable from pump or 3-way valve to appliance.
- ▶ Insert cable into the junction box as shown in Fig. 50.
- ▶ Connect cable to **the red plug** according to Fig. 49.

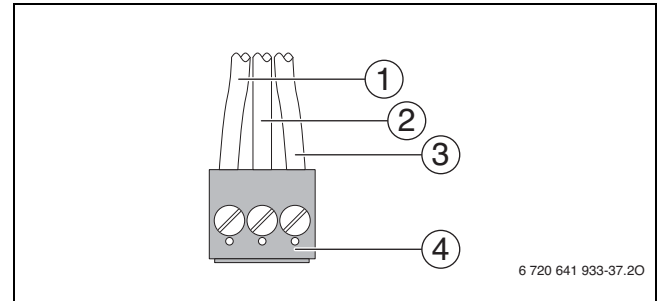

Fig. 49 Attach plug (external DHW tank loading pump or 3-way valve)

- [1] L (120 VAC, 60 Hz)
- [2] PE (GND, Ground)
- [3] N (Neutral)
- [4] Red plug (in the junction box upon delivery)

- ▶ Connect red plugs and insert grommet until stop.

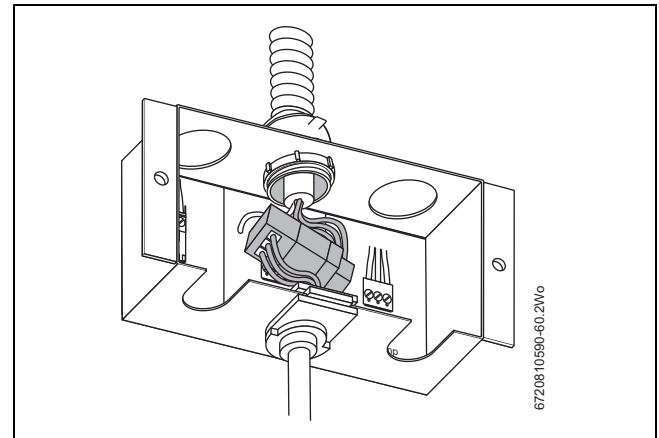

Fig. 50 Cable connected (external DHW tank loading pump or 3-way valve)

- ▶ Mount the 3-way valve for space heating operation when de-energized, and DHW tank loading when energized.
- ▶ Use service function 1.F to set pump mode. (→ page 54).

7.2.6 Connecting mains power supply

- ▶ Route the power cable (AC 120 V, 60 Hz) from the emergency shutoff switch to the boiler.
- ▶ Insert cable into the junction box as shown in Fig. 52.
- ▶ Connect cable to **the white plug** according to Fig. 51.

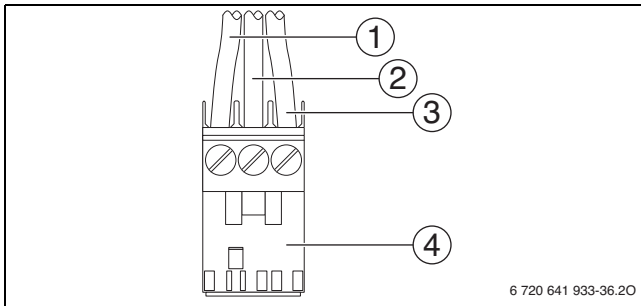

Fig. 51 Attach plug (mains power supply)

- [1] L (120 VAC, 60 Hz)
 - [2] PE (GND, Ground)
 - [3] N (Neutral)
 - [4] White plug (in the junction box upon delivery)
- ▶ Connect white plugs and insert grommet until stop.

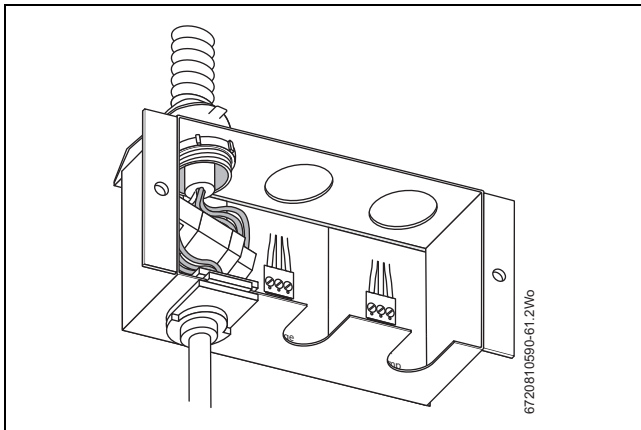

Fig. 52 Cable connected (mains power supply)

- ▶ Mount junction box on the rail.

7.2.7 Low voltage (LV) junction box

The low voltage installer junction box provides connections to sensors, thermostat and programmers.

Bosch room controls

Connect only Bosch room controls to the internal BUS of this boiler.

For installation and electrical connection of Bosch controls, see installation instructions for the Bosch control.

Connecting external manual reset high limit or low water cut off (LWCO)

This connection allows the installation of external safety switches.



Remove the link if using these connection points

- External manual reset high limit
- Low water cut-off (LWCO)
- Radiant overhear protection

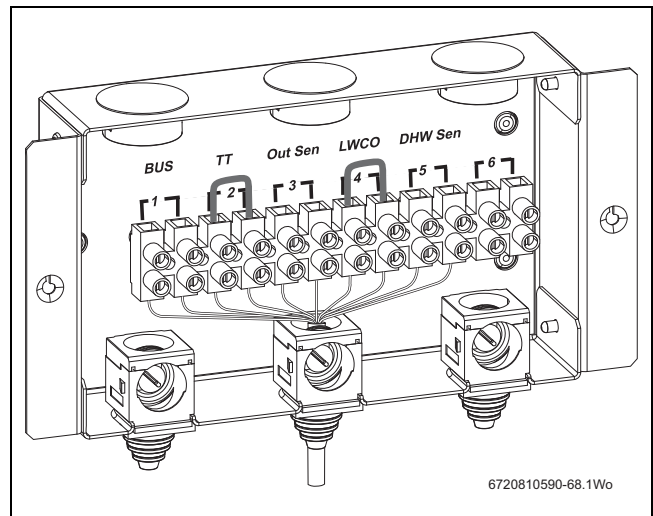

Fig. 53 Low voltage (LV) connections

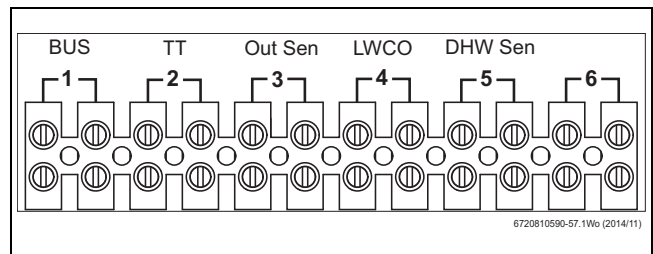

Fig. 54 Low voltage (LV) terminals (pre-wire links not shown for simplicity)

- [1] BUS - BUS connection to programmer
- [2] TT - Thermostat/On demand signal (pre-wired link) (dry contact)
- [3] Out Sen - Outdoor temperature sensor (included with FW200 accessory)
- [4] LWCO - Low Water Cut Off switch (pre-wired link) (external 24V power required)
- [5] DHW Sen - Domestic Hot Water tank temperature sensor
- [6] Empty (future connectivity)

7.3 DHW tank temperature sensor connection

Before connecting the DHW tank temperature sensor to the Low voltage (LV) connections.

- ▶ Remove the pre fitted connector [1] from DHW tank temperature sensor lead [2].
- ▶ The DHW tank temperature sensor lead can now be wired to the Low voltage (LV) connection "DHW Sen" position 5.

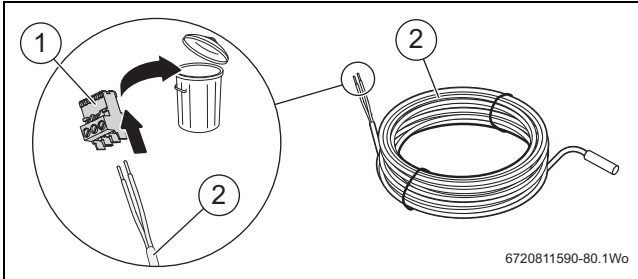

Fig. 55 DHW tank sensor connector plug removal

7.4 Connecting the LWCO device

- ▶ Install a 24VAC 20VA transformer near the boiler.
- ▶ Follow LWCO manufacturer's instructions.
- ▶ Connect the lead labeled BOILER GROUND (green) to pin 2 (center, → Fig. 51 [2]) of the white plug in the boiler junction box.
- ▶ Connect the leads labeled 24V HOT (red) and 24V COMMON (white) to the external 24VAC transformer.
- ▶ At the Low Voltage box on the rear of the boiler, remove the link across LWCO connections and connect the leads labeled SWITCH CONTACT (yellow) to these connections.

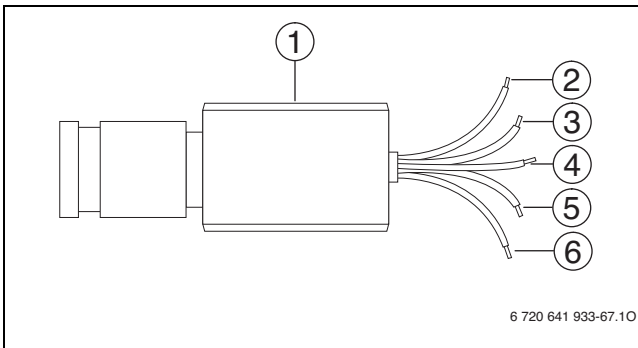

Fig. 56 Wires of a LWCO device with LWCO adapter

- [1] LWCO device (Hydrolevel Safgard 1100)
- [2] BOILER GROUND (green)
- [3] SWITCH CONTACT (yellow)
- [4] SWITCH CONTACT (yellow)
- [5] 24V HOT (red)
- [6] 24V COMMON (white)

8 Commissioning

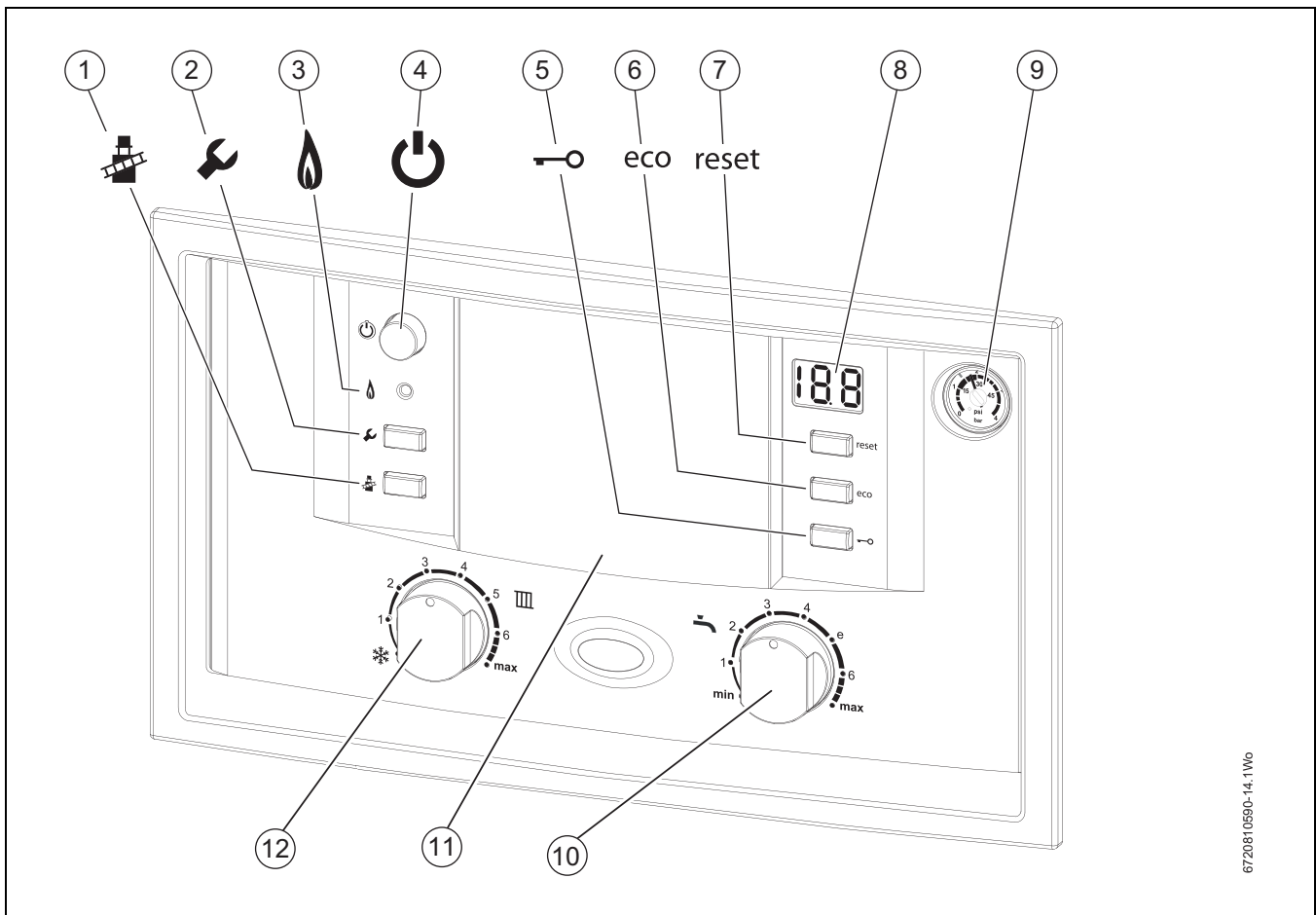

Fig. 57 Overview of the controls

- [1] Emissions test button
- [2] Service button
- [3] Burner operation indicator lamp
- [4] ON/OFF power switch
- [5] Key pad lock
- [6] ECO button
- [7] Reset button
- [8] Display
- [9] System water pressure gauge
- [10] DHW temperature control
- [11] Blank panel for optional programmer
- [12] Heating temperature control

8.1 Before operating the appliance

NOTICE: Commissioning without being properly filled and purged will damage the appliance.

- ▶ Only operate this appliance after ensuring there is sufficient water in the boiler and the system.

- ▶ Adjust the expansion (tank) vessel pre-charge pressure to the static head of the heating system (→ page 31).
- ▶ Manually open radiator and or zone valves as applicable.
- ▶ Open heating supply and return valves, fill heating system to 14.5 to 21.75 psi (1 - 1.5 bar) and close fill valve.

- ▶ Bleed all air from the system.
- ▶ If the boiler water pressure has dropped, fill the heating system again to 14.5 to 21.75 psi (1 to 1.5 bar).
- ▶ On KBR...-3A appliances (heating boilers) with a DHW tank, open the cold water supply and open a DHW tap until water runs out.
- ▶ Verify that the gas type specified on the rating plate is the same as the gas type used.
- ▶ Open the gas cock.

8.2 Switching the appliance ON/OFF

Startup

- ▶ Switch the appliance ON using the ON/OFF switch. The display indicates the supply temperature of the hot water in °F. If necessary, convert to °C (→ Service function 0.E: Metric or US customary units, page 57)

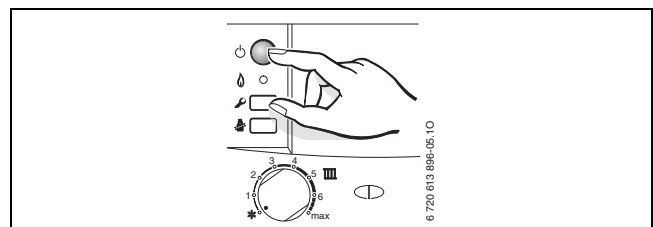

Fig. 58 Switching the appliance ON/OFF



When the appliance is switched ON for the first time, it performs a once-only purging sequence. This involves the heating zone pump switching on and off at intervals (for approx. 4 minutes).
The display shows in alternation with the supply temperature.

- ▶ Open the automatic vent [9] (only combi boiler KWB...-3A) and close it again when the purging sequence has finished (→ page 48).



If the display shows in alternation with the supply temperature, the trap filling function is active (→ page 56).

Shutdown

- ▶ Switch appliance OFF using the ON/OFF switch. The display goes out.
- ▶ If the appliance is taken out of service for a longer period: Observe frost protection (→ Section 8.9).

8.3 Setting up space heating

Set the maximum supply temperature based on the structure's heat loss on design day.

Boiler high limit dial	Typical supply temperatures	Sample application
1	approx. 95 °F (35 °C)	Frost protection
2	approx. 109 °F (43 °C)	
3	approx. 122 °F (50 °C)	Radiant floor heating system
4	approx. 140 °F (60 °C)	Panel radiator system
5	approx. 153 °F (67 °C)	Cast iron radiator system
6	approx. 167 °F (75 °C)	
max	approx. 194 °F (90 °C)	Baseboard & convector system

Table 16 Typical supply temperatures



With radiant floor heating, limit the maximum permissible supply temperature as recommended by the manufacturer.

- ▶ In order to set the maximum supply temperature, turn the boiler high limit dial .

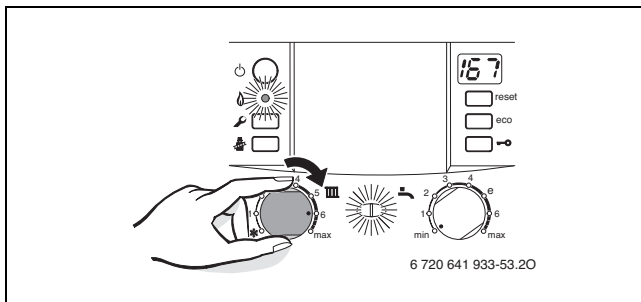

Fig. 59 Switch on heat

If the burner is operating, the burner operation indicator lamp is illuminated.

8.4 Programming the Bosch Room Controller



Refer to the operating instructions for the Bosch room controller included in the scope of delivery. The instructions contain information on:

- ▶ setting up the operating mode
- ▶ adjusting the room temperature
- ▶ heating economically for comfortable temperatures
- ▶ mounting the controller in the reference room

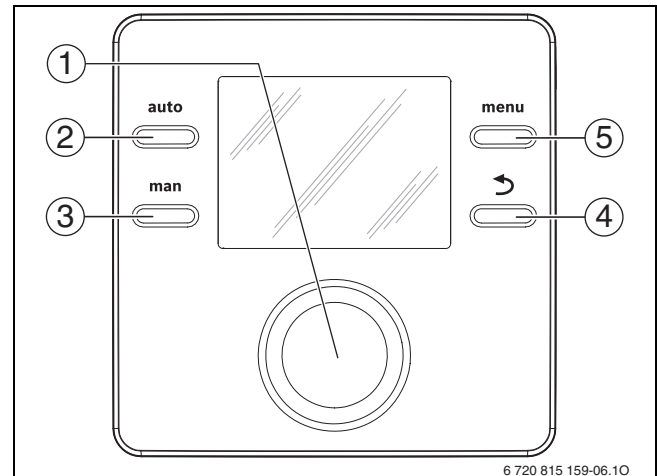

Fig. 60 FW 200 controls

Item	Name	Description
1	Knob	Turn to change a setting or select a menu/menu item. Press to open a menu/menu item or confirm a setting/message.
2	auto	Press to activate the automatic mode
3	man	Press to active the hold mode (manual operation)
4	back	Press to return to the next higher menu level or to discard a setting Press for an extended period of time to close the main menu
5	menu	Press to open the main menu

Table 17

8.5 After commissioning

- ▶ Check flue path for tightness.
- ▶ Check gas supply dynamic pressure (→ page 61).
- ▶ Check that condensate is being discharged from the condensate hose. If that is not the case, switch the appliance first OFF and then ON again using the ON/OFF switch. That activates the trap filling sequence (→ page 56). Repeat the procedure several times until condensate starts running out.
- ▶ Complete commissioning report (→ page 75).

8.6 KBR..-3A appliances (heating boilers) with DHW tank: Setting the DHW temperature

- ▶ Set the DHW temperature on the DHW thermostat . The set DHW temperature flashes on the display for 30 seconds.

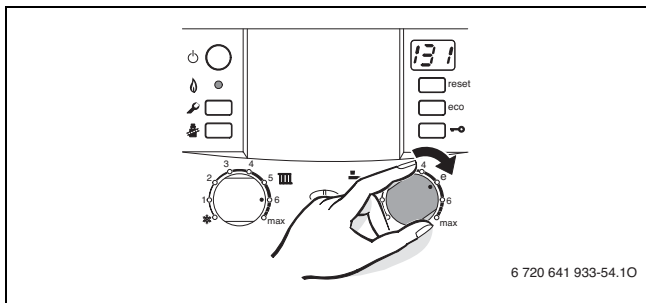

Fig. 61 Set the DHW temperature (heating boiler KBR..-3A)

DHW thermostat 	Typical DHW temperatures
min	approx. 59 °F (15 °C)
e	approx. 131 °F (55 °C)
max	approx. 158 °F (70 °C)

Table 18 Typical DHW temperatures for heating boiler KBR..-3A



WARNING: Danger of scalding!

- ▶ In normal operation, it is recommended to limit the DHW temperature to 122 °F (50 °C) to limit the risk of scalding.
- ▶ Install a tempering valve if running DHW temperatures above 104 °F (40 °C).
- ▶ Only use temperatures up to 158 °F (70 °C) for thermal disinfection (→ page 51).



If there is reason for concern for contamination from bacteria such as Legionella, consider setting the DHW thermostat  to at least "e" (131 °F (55 °C)). This setting ensures an economical and comfortable DHW generation. Consult your local water department or municipality for further information.

ECO button

The default setting is DHW priority; the ECO button is not lit. In order to switch between **DHW tank priority** and **alternating operation**, press the ECO button.

- **DHW priority**
First, the DHW tank is heated up to the set temperature. The appliance then goes into heating mode. Therefore, it can happen that space heating is interrupted for a while and the room temperature may drop.
DHW tank priority guarantees highest DHW comfort.
- **Alternating operation**
The appliance switches between space heating mode and DHW mode. This prevents the room from cooling off too much. Alternating operation guarantees an even room temperature with somewhat less DHW convenience.

8.7 KWB..-3A appliances (combi boilers): Setting the DHW temperature

- ▶ Set the DHW temperature on the DHW thermostat . The set DHW temperature flashes on the display for 30 seconds.

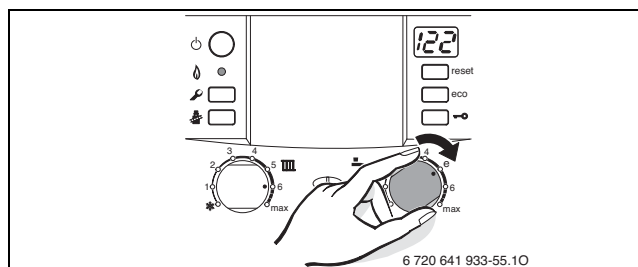

Fig. 62 Set the DHW temperature (combi boiler KWB..-3A)

DHW thermostat 	Typical DHW temperatures
min	approx. 104 °F (40 °C)
e	approx. 122 °F (50 °C)
max	approx. 140 °F (60 °C)

Table 19 Typical DHW temperatures for combi boiler KWB..-3A

ECO button

Pressing and holding the ECO button until it lights up switches between **Comfort mode** and **Economy mode**.

- **Comfort mode (default setting)**
The appliance is continually maintained at the set temperature. Consequently, DHW draws are immediate, however the appliance may run even if no DHW is being drawn.
- **Economy mode, ECO button lights up**
 - DHW is only generated when DHW is drawn.
 - **On demand:** Quickly open and close a DHW tap to signal the appliance to heat to the selected temperature. After a short wait DHW will be available.



The DHW on demand signal allows maximum gas and water savings.

8.8 Setting manual summer mode



In summer mode or warm weather shut down (WWSD), the heating zone pump and consequently central heating are switched off. DHW generation remains active following the DHW program.



See also the warm weather shutdown (WWSD) feature in the operating instructions for the heating control included in the scope of delivery.

NOTICE: Heating system at risk of freezing. In manual summer mode, only the appliance is protected from freezing.

- ▶ Observe frost protection measures where there is a risk of frost (→ Chapter 8.9).

- ▶ Make a note of the setting of the boiler high limit dial .
- ▶ Turn the boiler high limit dial  counterclockwise to .

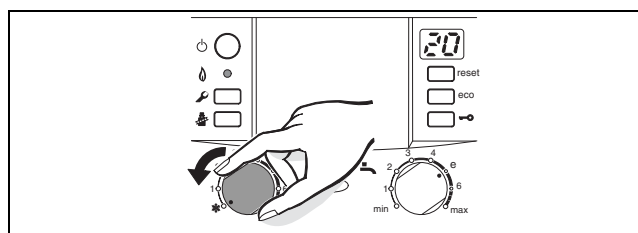

Fig. 63 Summer mode

For further information, see the operating instructions for the heating control included in the scope of delivery.

8.9 Setting frost protection

Frost protection of the heating system:

- ▶ Leave the appliance switched ON; set the boiler high limit to at least 95 °F (35 °C) (position 1, → Tab. 16, page 49).

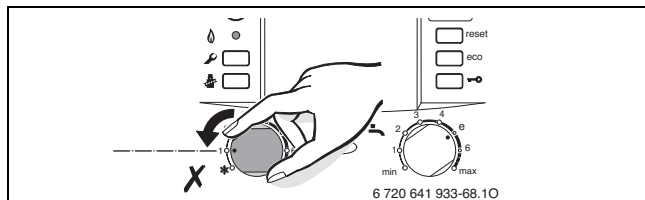

Fig. 64 Frost protection of the heating system

-or- If you want to leave the appliance switched OFF:

- ▶ Mix Bosch-approved anti-freeze into the heating water (→ Tab. 5, page 30) and drain the DHW circuit.



For further information, see the operating instructions for the heating control included in the scope of delivery.

Frost protection of the DHW tank:

- ▶ Leave the appliance switched ON; set the boiler high limit to at least 95 °F (35 °C) (position 1, → Tab. 16, page 49).
- ▶ Turn the DHW thermostat counter-clockwise to **min** (59 °F (15 °C)).

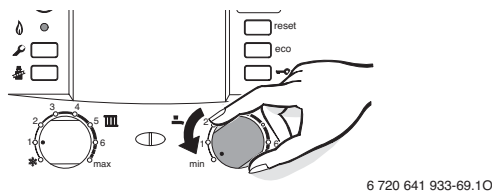



Fig. 65 Frost protection for the DHW tank

8.10 Activating the key pad lock

The key pad lock affects the boiler high limit dial, the DHW thermostat, and all buttons except the ON/OFF switch, emissions test button, and reset button. It can be used to limit unauthorized access to the boiler.

Activating the key pad lock:

- ▶ Press the key pad lock button until  and the heating supply temperature are alternating on the display.

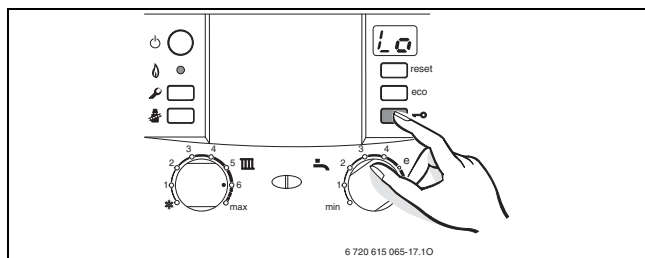

Fig. 66 Key pad lock

Unlocking the key pad:

- ▶ Press the key pad lock button until the display shows only the supply temperature.

9 KBR..-3A appliances (heating boiler) with DHW tank: Thermal disinfection

Thermal disinfection covers the DHW system including the taps. For solar DHW tanks, the solar portion of the tank is not covered.



WARNING: Risk of scalding!

Hot water can result in severe scalding.

- ▶ Carry out thermal disinfection only outside the normal hours of use, or install a tempering valve.

- ▶ Close all DHW taps.
- ▶ Advise occupants of the risk of scalding if no tempering valve is installed.
- ▶ Set the time and DHW temperature accordingly on the heating control with DHW program.
- ▶ Set any DHW recirculation pump to continuous operation.
- ▶ Turn DHW thermostat clockwise to **max** (approx. 158 °F (70 °C)).

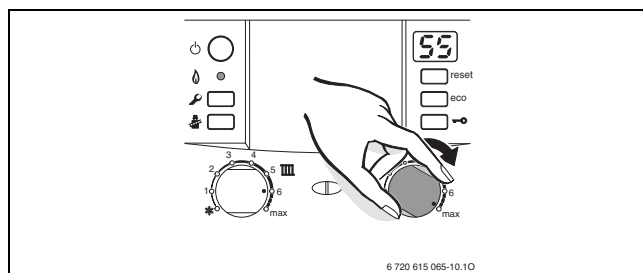

Fig. 67 Thermal disinfection

- ▶ Wait until the maximum temperature has been reached.
- ▶ Open all DHW taps, from the nearest to the one furthest away, and draw off hot water until it reaches a minimum of 158 °F (70 °C) at all taps for at least 3 minutes.
- ▶ Reset the DHW thermostat, DHW recirculation pump, and heating control to standard operation.



Thermal disinfection can also be carried out automatically and on a regular basis; see operating instructions for the heating control included in the scope of delivery.

10 Boiler circulator

10.1 Pump anti-seize protection



This function prevents the heating zone pump from seizing up following longer idle periods.

The appliance will briefly run the pump at least every 24 hours after its last activation.

10.2 Changing the pump curve of the boiler pump

The speed of the boiler pump can be changed using the dial on the pump.

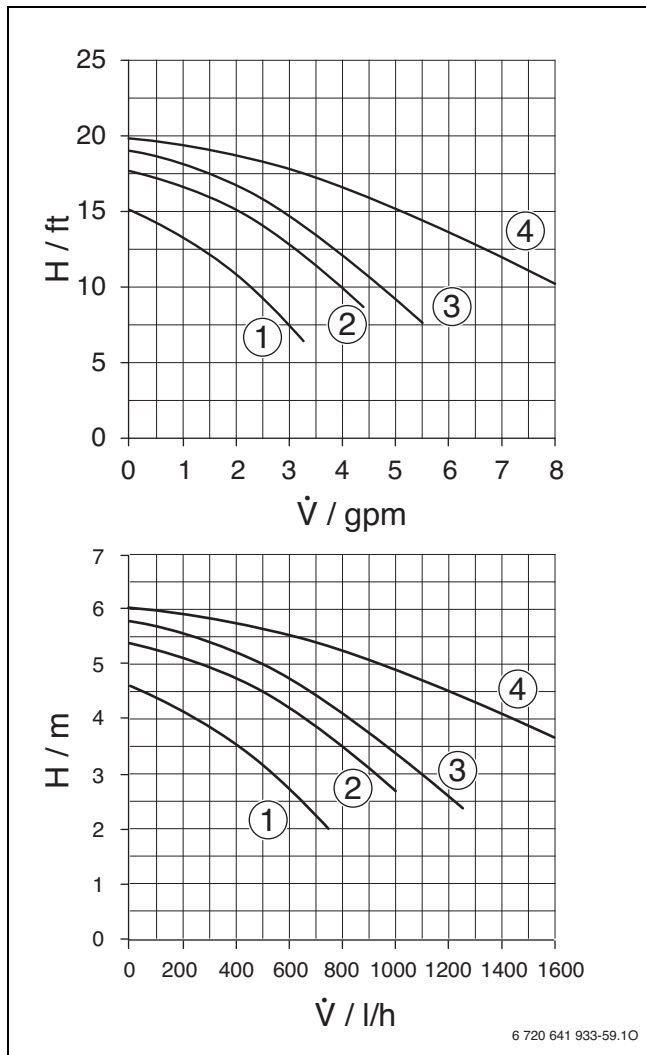

Fig. 68 Pump curve of the boiler pump heating boiler KBR..-3A

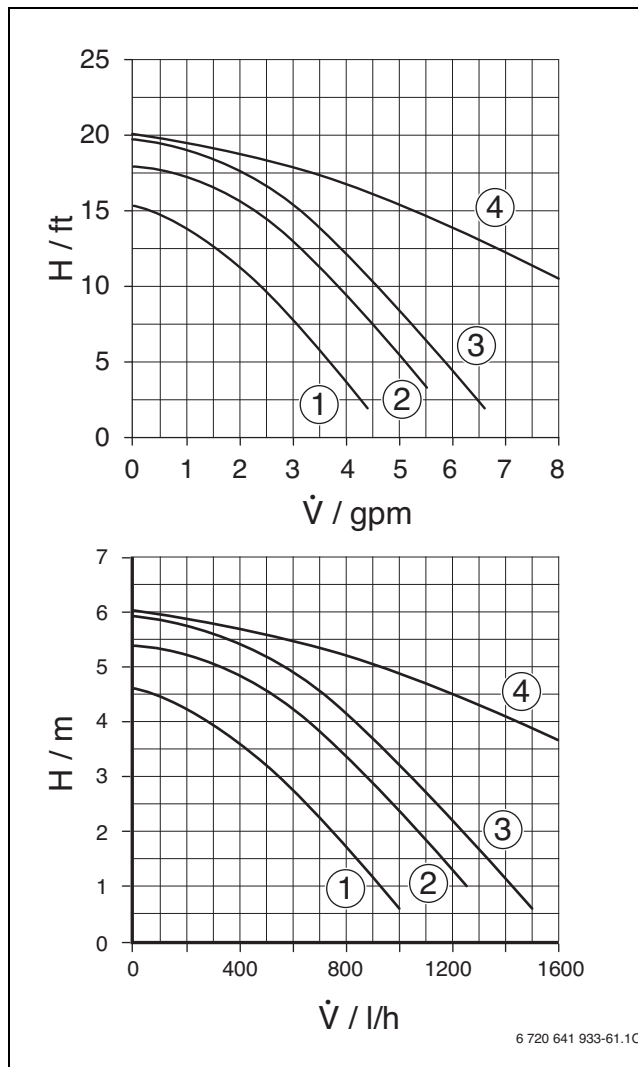

Fig. 69 Pump curve of the boiler pump combi boiler KWB..-3A

Key to Fig. 68 and Fig. 69:

- [1] Residual head pressure at speed 1
- [2] Residual head pressure at speed 2
- [3] Residual head pressure at speed 3 (default setting)
- [4] Head pressure of the boiler pump by itself (at speed 3)
- H Head pressure in feet of head (m)
- \dot{V} Circulating water volume in gallons per minute (l/h)



In order to save as much energy as possible and keep any water circulation noises to a minimum, select the lowest possible pump speed.

11 Heatronic boiler control settings

11.1 Guideline to service functions

The Heatronic allows easy setting and testing of many appliance functions.

For an overview of service functions, see Chapter 11.2 on page 53.

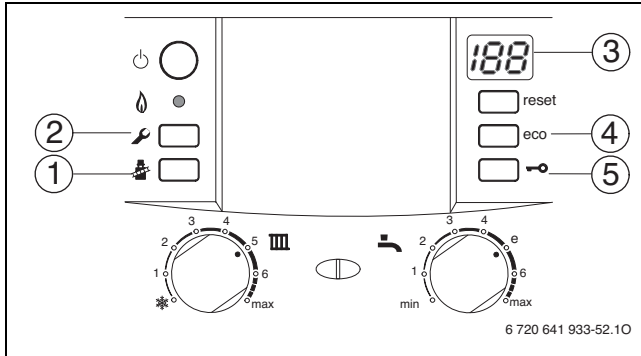



Fig. 70 Overview of the controls

- [1] Emissions test button
- [2] Service button
- [3] Display
- [4] ECO button, service functions “up”
- [5] Key pad lock, service functions “down”

Selecting a service function



The service functions are subdivided into two levels: The **1st level** includes service functions **up to 0.E**, the **2nd level** includes service functions **starting with 8.A**.

- ▶ Press and hold the service button  until it illuminates. The display shows a code such as 1.A (first service level).
- ▶ Repeatedly press the key pad lock button or ECO button to scroll to the desired service function.
- ▶ Press and release the emissions test button . The emissions test button will light up and the display shows the setting for the selected service function.

Adjust Value

- ▶ Repeatedly press the key pad lock button or ECO button to adjust the value up or down.
- ▶ Record the value in the commissioning log (→ page 75).



Saving the value

- ▶ Press and hold the emissions test button  until the display shows  (value saved).



The unit automatically exits the service level if no button is pressed for 15 minutes.

Exiting the service function without saving values

- ▶ Briefly press the emissions test button . The light of the emissions test button  will go out.

Restoring factory settings

In order to reset all values for the service levels 1 and 2 to the factory setting:

- ▶ Press and hold the service button until it illuminates. The display shows a code such as 1.A (first service level). Press the ECO button and key pad lock button simultaneously until the code 8.A appears (second service level).
- ▶ On the second service level, select the service function 8.E and value **00**. The appliance restarts with the default settings.

11.2 Overview of the service functions

11.2.1 First service level (press and hold the service button until it lights up)

Service function		
Display		Page
1.A	Maximum space heating output	54
1.b	Maximum DHW output	54
1.E	Pump mode for space heating operation	54
1.F	Pump mode	54
2.A	Heating circuit pump lockout time	54
2.b	Maximum supply temperature	54
2.C	Purging function	55
2.d	Thermal disinfection	55
2.F	Operating mode	55
3.A	Automatic anti-cycle function	55
3.b	Set anti-cycle time	55
3.C	Switching differential (hysteresis)	55
3.d	Minimum output (heating and DHW)	55
3.E	Cycle time, keeping DHW hot	55
3.F	Constant DHW period	56
4.b	Maximum heat exchanger temperature	56
4.d	Audible fault warning tone	56
4.E	Appliance type	56
4.F	Condensate trap filling sequence	56
5.A	Reset inspection interval	56
5.b	Fan post purge time	56
5.E	Functionality of black plug in boiler junction box	56
5.F	Set inspection interval	56
6.A	Display the latest fault code	57
6.b	Room temperature control, current voltage, terminal 2	57
6.C	Supply temperature required by weather compensation control	57
6.d	Current DHW turbine flow rate	57
7.A	Indicator lamp for burner operation / faults	57
7.b	3-way valve in center position	57
7.d	Connecting an external supply or low-loss header temperature sensor	57
7.E	Building drying function	57
0.A	Do not use this setting!	57
0.d	Altitude adjustment	57
0.E	Metric or US customary units	57

Table 20 Service functions, 1st level

11.2.2 Second service level (at first service level, service button lights up, press ECO button and key pad lock button simultaneously until 8.A appears)

Service function	Display	Page
8.A	Software version	57
8.b	Code plug number	58
8.C	GFA Gas burner control status	58
8.d	GFA Gas burner control fault	58
8.E	Restore boiler to factory settings	58
8.F	Permanent ignition	58
9.A	Constant mode	58
9.b	Current fan speed	58
9.C	Current boiler output	58
9.d	Set fan start speed	58
9.E	Turbine signal delay	58
9.F	Heating zone pump post purge	58
A.b	Display DHW temperature	58
A.C	Display DHW tank temperature	58
b.F	Solar DHW backup heating delay	58
C.d	Display current heat demand	58

Table 21 Service functions, 2nd level

11.3 Description of the service functions

11.3.1 First service level

Service function 1.A: Maximum space heating output

Some gas supply companies offer a performance-dependent basic price.

The output can be limited in percent between the minimum and maximum nominal output to suit the specific heat demand.



Even if the heating output has been limited, the maximum nominal output is still available for DHW generation.

- ▶ Select service function 1.A.
- ▶ Select heat output in MBH (kW) and determine associated setting in percent (%).
- ▶ Enter the setting (→ 11.1).
- ▶ Save the setting (→ 11.1).
- ▶ Record the set heat output in the commissioning log (→ page 75).
- ▶ Exit the service functions.
The display returns to the supply temperature.

Default setting is the maximum nominal output: **100** (100 %).

Service function 1.b: Maximum DHW output

The hot water output can be adjusted between the minimum and maximum DHW outputs to suit the heat transfer capacity of the DHW tank coil.

- ▶ Select service function 1.b.
- ▶ Select the DHW output in MBH (kW) and determine the associated setting in percent (%).
- ▶ Enter the setting (→ 11.1).
- ▶ Save the setting (→ 11.1).
- ▶ Record the set DHW output in the commissioning log (→ page 75).

- ▶ Exit the service functions.
The display returns to the supply temperature.

Default setting is the maximum nominal output: **100** (100 %).

Service function 1.E: Pump mode for space heating operation



If an outdoor temperature sensor for a weather compensation control is connected, pump control mode 04 is automatically set.

- **Pump control mode 00 (automatic mode):** The BUS control controls the central heating pump.
- **Pump control mode 01:** For heating systems without control. The supply temperature controls the central heating pump. When there is a demand for heat, the central heating pump and the burner start up.
- **Pump control mode 02:** Do not use.
- **Pump control mode 03:** The central heating pump runs continuously (exceptions: See heating control operating instructions).
- **Pump control mode 04:** Intelligent control of central heating pump in heating systems with weather compensation control. The heating zone pump is only switched on when needed.

Default setting is **00**.

Service function 1.F: Pump mode (only heating boiler KBR...-3A)

NOTICE: System damage or boiler malfunction!

- ▶ Never change the setting of this service function on combi boiler KWB...-3A appliances.

Based on this setting, the pump connected to the Heatronic or 3-way valve are controlled according to the configuration of the heating system.

The following settings are possible:

- **Pump mode 00:** The appliance is used only as central heating boiler.
- **Pump mode 01:** A 3-way valve for DHW tank loading is connected in boiler circuit before low loss header (see also service function 2.A).
- **Pump mode 02:** Do not use this setting!
- **Pump mode 03:** A DHW tank pump is connected on the system side after the low loss header.
In DHW mode, DHW tank loading pump runs.
In space heating mode, DHW tank loading pump does not run.

Default setting is **03**.

Service function 2.A: Heating circuit pump lockout time (only heating boiler KBR...-3A)

NOTICE: System damage or boiler malfunction!

- ▶ Never change the setting of this service function on combi boiler KWB...-3A appliances.



This setting is only active if Service function 1.F: Pump mode is set to 01 (3-way valve).

During the runtime of an external 3-way valve actuator, the space heating pump is blocked. Select the run time of the 3-way valve actuator between **01 - 24** (10 - 240) seconds according to the manufacturer's documentation.

Default setting is **24** (240 seconds).

Service function 2.b: Maximum supply temperature

The values of this service function displayed depend on the setting of the service function **0.E**:

Service function **0.E** is set to **00** (metric units):

- The maximum supply temperature can be adjusted between **35** and **86** (35 - 86 °C).

Service function **0.E** is set to **01** (US customary units):

- The maximum supply temperature can be adjusted between **96** and **187** (96 - 187 °F).

Default setting is **190** (190 °F (88 °C)).

Service function 2.C: Purging function



When the appliance is switched ON for the first time, it performs a once-only purging sequence. This involves the heating zone pump switching on and off at intervals (for approx. 4 minutes).
The display shows in alternation with the supply temperature.



This service function allows activating the purging function manually, e.g. after servicing.

The following settings are possible:

- **00**: Purging function off
- **01**: Purging function is switched on and after completion automatically reset to **00**
- **02**: Purging function is permanently on and is not reset to **00**

Default setting is **00** for heating boilers KBR...-3A appliances, otherwise **01**.

Service function 2.d: Thermal disinfection (legionella protection)



WARNING: Risk of scalding!

Hot water can result in severe scalding.

- ▶ Carry out thermal disinfection only outside the normal hours of use.
- ▶ Install a tempering valve if this function is enabled permanently.

When this service function is enabled, the DHW is **permanently** heated to approx. 158 °F (70 °C) if the DHW temperature dial has been turned clockwise to **max**.

The following settings are possible:

- **00**: Thermal disinfection not enabled
- **01**: Thermal disinfection enabled

Default setting is **00** (disabled).

Service function 2.F: Operating mode

With this service function, you can temporarily change the appliance's operating mode.

The following settings are possible:

- **00**: Default mode; the appliance runs according to control settings.
- **01**: The appliance runs for 15 minutes at minimum output. The display shows 2.F. When this service function is aborted or has been active for 15 minutes, the appliance reverts to default mode.
- **02**: The appliance runs for 15 minutes at maximum output. The display shows 2.F. When this service function is aborted or has been active for 15 minutes, the appliance reverts to default mode.

Default setting is **00**.

Service function 3.A: Automatic anti-cycle function



If an outdoor reset control is connected, there is no need to adjust this setting on the appliance.
The control automatically optimizes the anti-cycle time.

Use service function 3.A to set the automatic adaptation of the anti-cycle time. This can be required in case of unfavorably-dimensioned heating systems. Short cycling may increase boiler and system wear and tear, increase emissions, reduce comfort, and should be avoided.
With auto-adaptation of the anti-cycle time disabled, the anti-cycle time must be set using service function 3.b (→ page 55).

The following settings are available:

- **00**: Automatic adaptation of the anti-cycle time is disabled
- **01**: Automatic adaptation of the anti-cycle time is enabled

Default setting is **00** (switched off).

Service function 3.b: Set anti-cycle time

Only if the automatic anti-cycle time is disabled (service function 3.A) will this function be active.



If an outdoor reset control is connected, there is no need to adjust this setting on the appliance.
The control automatically optimizes the anti-cycle time.

The anti-cycle time can be set from **00** to **15** (0 to 15 minutes).

With **00**, the anti-cycle lock is switched off.

The shortest possible switching interval is 1 minute (recommended for single zone or forced air heating systems).

Default setting is **03**.

Service function 3.C: Switching differential

Only if the automatic anti-cycle time is disabled (service function 3.A) will this function be active.



If an outdoor reset control is connected, there is no need to adjust this setting on the appliance.
The control automatically optimizes this setting.

The switching differential is the permitted boiler differential from the target supply temperature. It can be set in increments of 1 °F (0.5 °C). The minimum supply temperature is 95 °F (35 °C).

Service function **0.E** is set to **00** (metric units):

- You can set the switching differential between **00** and **30** (0 - 30 °C).

Service function **0.E** is set to **01** (US-customary units):

- You can set the switching differential between **00** and **54** (0 - 54 °F).

Default setting is **18** (18 °F (10 °C)).

Service function 3.d: Minimum output (heating and DHW)

The output for heating and DHW can be set to any level in percent between the minimum and maximum nominal output.

The **default setting** is the minimum nominal output (heating and DHW) and varies according to appliance.

Service function 3.E: Cycle time, keeping DHW hot (only combi boiler KWB...-3A)

NOTICE: System damage or boiler malfunction!

- ▶ Never change the setting of this service function on heating boiler KBR...-3A appliances.

This service function is only active in comfort mode.

It specifies the time from completion of preheating or DHW demand until the next time the plate-type heat exchanger is heated up. This prevents the plate-type heat exchanger from overheating.

The cycle time can be set from **20** to **60** minutes.

Default setting is **20** (20 minutes).

Service function 3.F: Constant DHW period (only combi boiler KWB..-3A)

NOTICE: System damage or boiler malfunction!

- ▶ Never change the setting of this service function on heating boiler KBR..-3A appliances.

The constant DHW period specifies how long the space heating mode remains disabled after DHW is drawn.

The duration for keeping DHW hot can be set from **00** to **30** (0 to 30 minutes).

Default setting is **01** (1 minute).

Service function 4.b: Maximum heat exchanger temperature (only combi boiler KWB..-3A)

NOTICE: System damage or boiler malfunction!

- ▶ Never change the setting of this service function on heating boiler KBR..-3A appliances.

This function can be used to reduce limestone built-up in the heat exchanger, which increases with temperature. The maximum heat exchanger temperature can be set in steps of 1 °F (0.5 °C).

Service function **0.E** is set to **00** (metric units):

- The maximum temperature for keeping the heat exchanger hot can be set from **40** to **65** (40 to 65 °C).

Service function **0.E** is set to **01** (US-customary units):

- The maximum temperature for keeping the heat exchanger hot can be set from **104** to **150** (104 to 150 °F).

Default setting is **140** (140 °F (60 °C)).

Service function 4.d: Audible fault warning tone

The appliance can be set to sound an audible alarm to alert the operator of a fault present. The audible warning tone can be deactivated with the service function 4.d.

- **00:** Warning tone off
- **01:** Warning tone on

Default setting is **01** (ON).

Service function 4.E: Appliance type

This service function displays the appliance type detected.

Possible displays are:

- **00:** Central heating only
- **01:** Combi appliance
- **02:** DHW tank temperature sensor (NTC) connected to Heatronic.
- **03:** DHW tank thermostat connected to Heatronic.
- **04:** Stratified DHW tank
- **05:** Tank with NTC return

Service function 4.F: Condensate trap filling sequence



DANGER: Risk of flue gas poisoning!

If the condensate trap is not filled, flue gas may escape from the dry trap.

- ▶ Only deactivate the trap filling sequence for servicing purposes.
- ▶ When servicing is complete, reactivate the trap filling function.

The trap filling sequence ensures that the condensate trap is filled after initial installation or after a longer downtime of the appliance.

The trap filling sequence is activated if:

- The appliance is switched OFF using the ON/OFF switch
- The burner has not been in use for at least 28 days
- You are switching between summer and winter mode

The next time there is a demand for heat in central heating or hot water mode, the appliance is held at low output for 15 minutes. The trap filling sequence remains active until the appliance has completed 15 minutes of operation at low output. The display shows \bar{H} in alternation with the supply temperature.

The following settings are available:

- **00:** Condensate trap filling sequence is off.
- **01:** Trap filling program at the lowest output.
- **02:** Trap filling sequence at set minimum output.

Default setting is **01**.

Service function 5.A: Reset inspection interval

This function enables resetting the indication \bar{H} on the display after completing inspection/servicing of the appliance.

Default setting **00**.

Service function 5.b: Fan post purge time

This service function allows setting the time the fan purges after the burner is shut off.

The post purge time can be set from **01** to **18** (10 - 180 seconds).

Default setting is **03** (30 seconds).

Service function 5.E: Functionality of black plug in boiler junction box

With this service function you can set the functionality of the black plug in the boiler junction box (→ page 45).

The following settings are possible:

- **00:** Off - black connector in junction box is disabled (120VAC output deactivated).
- **01:** DHW recirculation pump enabled - see FW200 instructions on how to set a recirculation pump program.
- **02:** External heating zone pump in heating circuit without 3-way valve controlled by FW 200.
- **03:** External heating zone pump in heating circuit without mixer controlled by Heatronic running in parallel with boiler pump in central heating mode

Default setting is **03**.

Service function 5.F: Set inspection interval

This service function allows setting the number of months after which the 'service due' reminder \bar{H} appears on the display alternating with the supply temperature.

The number of months can be set from **00** - **72** (0 to 72 months).

Default setting is **00** (disabled).



If **U0** appears on the display, the function was already set via the FW200 control.

Service function 6.A: Display the latest fault code

Use this service function to display the most recent fault code.

Service function 6.b: Room temperature control, current voltage, terminal 2

The current voltage of the analog control at terminal 2 is displayed.

Possible displays are:

- **00 - 24:** 0 V to 24 V in increments of 1 V

Service function 6.C: Supply temperature required by weather compensation control

This service function allows displaying the current target supply temperature set by the weather compensation control.

Service function 6.d: Current DHW turbine flow rate (only combi boiler KWB..-3A)

NOTICE: System damage or boiler malfunction!
 ▶ Never change the setting of this service function on heating boiler KBR..-3A appliances.

The current flow rate of the DHW turbine is displayed.

Service function **0.E** is set to **00** (metric units):

- **0.0. - 99.9.:** 0.0 to 99 l/min in increments of 0.1 l/min

Service function **0.E** is set to **01** (US-customary units):

- **0.0. - 99.9.:** 0.0 to 99 gpm in increments of 0.1 gpm

Service function 7.A: Indicator lamp for burner operation / faults

With this service function you can activate and deactivate the indicator lamp for burner operation (continuously illuminated) and faults (flashing).

The following settings are possible:

- **00:** Off
- **01:** On (burner operation) and flashing (fault present)

Default setting is **00**.

Service function 7.b: 3-way valve in center position

After the value **01** has been saved, the 3-way valve moves to the center position. This allows draining the system completely and removing the motor easily.

When you exit this service function, the appliance returns to setting **00**.

Service function 7.d: Connecting an external supply or low-loss header temperature sensor

Presence of an external supply or low loss header temperature sensor is automatically detected by default; you do not need to change any settings.



If a sensor is disconnected, change the setting back to the default setting **00**.

The following settings are available:

- **00:** Once-only automatic detection of a sensor
- **01:** External supply temperature sensor connected to Heatronic.
- **02:** External supply temperature sensor connected to IPM2.

Default setting is **00**.

Service function 7.E: Building drying function

This service function allows you to start and stop the building drying function.



Never confuse the appliance building drying function with the slab drying function of the outdoor reset control FW200.



When the building drying function is on, you cannot adjust the appliance gas settings.

The following settings are available:

- **00:** Off
- **01:** Heating operation only in accordance with the appliance or control setting, i.e. all other heat demands are blocked.

Default setting is **00**.

Service function 0.A: Do not use this setting!

Default setting is **00** (disabled).

Service function 0.d: Altitude adjustment

Input and output rates are reduced at higher altitudes due to thin air with reduced oxygen levels.

KBR42-3A... and KWB42-3A... appliances are derated at 3 % per 1000 feet (305 m).

KBR16-3A..., KBR21-3A..., KBR28-3A..., KBR35-3A..., KWB28-3A... and KWB35-3A... appliances offer altitude adjustment which compensates for the effects of thin air, and are therefore NOT derated up to 6000 feet (1829 m). Above 6000 feet (1829 m) a rate of 3 % per 1000 feet (305 m) applies.

This service function is used to adjust the fan speed for high altitude operation.

The following settings are available:

- **00:** Normal
- **01:** Medium
- **02:** High

Setting	Elevation above sea level
00	0 ft – 2,000 ft (0 m – 610 m)
01	2,001 ft – 4,500 ft (611 m – 1 372 m)
02	above 4,500 ft (1 372 m)

Table 22 Altitude adjustment (service function 0.d)

Default setting is **00**.

Service function 0.E: Metric or US customary units

With this service function you can set if Metric or US customary units are displayed on the boiler.

The following settings are available:

- **00:** °C, l/min (metric units)
- **01:** °F, gpm (US-customary units)

Default setting is **01**.

11.3.2 Second service level

Service function 8.A: Software version

The current software version is displayed.

Service function 8.b: Code plug number

The last four digits of the code plug number are shown. The code plug determines the appliance functions. The code plug must be changed if the appliance has been converted from natural gas to LPG (or vice versa).

Service function 8.C: GFA Gas burner control unit status

Internal parameter. If you are on the line with Bosch Technical Support you may be asked for this number.

Service function 8.d: GFA Gas burner control unit fault

Internal parameter.

Service function 8.E: Restore boiler to factory settings

This function allows resetting all parameters of the boiler including all service functions to their factory settings.

- ▶ Press and hold the service button until it illuminates. The display shows a code such as 1.A (first service level).
- ▶ Press and hold ECO button and key pad lock button simultaneously until a service function, e.g. 8.A, is displayed (second service level).
- ▶ Repeatedly press the key pad lock button or ECO button until service function 8.E is displayed.
- ▶ Press and release the emissions test button . The emissions test button lights up and the display shows 00.
- ▶ Press and hold the emissions test button until the display shows . All settings are reset and the appliance restarts with the default settings.
- ▶ Reset altered service functions to the settings recorded in the commissioning log (→ page 75).

Service function 8.F: Permanent ignition

NOTICE: Ignition transformer damage.

- ▶ Never leave this function on for longer than 2 minutes at a time.

This function enables permanent ignition without gas supply to test the performance of all ignition related components.

The following settings are available:

- 00: Off
- 01: On

Default setting is 00.

Service function 9.A: Constant mode

This function sets one operating mode permanently (→ Service function 2.F: Operating mode, page 55).

The following settings are available:

- 00: Default mode: the appliance runs according to control settings.
- 01: The appliance runs permanently at minimum output. The display shows 9.A.
- 02: The appliance runs permanently at maximum output. The display shows 9.A.

Default setting is 00.

Service function 9.b: Current fan speed

This service function allows you to display the current fan speed in revolutions per second (1/s).

Service function 9.C: Current boiler output

This service function displays the current boiler output (in percent (%)).

Service function 9.d: Set fan start speed

At higher elevations the boiler fan may need to spin faster upon startup to ensure reliable ignition every time. The start speed of the boiler fan can be set from 45 to 77 revolutions per second (1/s).

Default setting is 50.

Service function 9.E: Turbine signal delay (only combi boiler KWB..-3A)

NOTICE: System damage or boiler malfunction!

- ▶ Never change the setting of this service function on heating boiler KBR..-3A appliances.

This service function allows setting a time delay to prevent the appliance starting up as a result of transient pressure spikes in the water supply.

Through spontaneous pressure change in the water supply, the flow meter (turbine) can signal that DHW is being drawn and cause the burner to come on unnecessarily.

The turbine signal delay can be set from 02 to 08 (0.5 seconds to 2 seconds) in increments of 0.25 seconds.

Default setting is 04 (1 second).

Service function 9.F: Heating zone pump post purge

This service function allows setting a pump post purge time after the end of the heat demand from the external control.

The pump post purge time can be set from 01 to 10 (1 to 10 minutes).

Default setting is 03.

Service function A.b: Display DHW temperature

This service function allows displaying the current DHW temperature.

Service function A.C: Display DHW tank temperature

This service function allows displaying the temperature of the DHW tank temperature sensor.

Service function b.F: Solar DHW backup heating delay (only combi boiler KWB..-3A)

For systems with a solar thermal DHW tank in series before the DHW line of the combi boiler. DHW heating by the boiler will be suppressed expecting that solar thermal DHW will reach the hot water temperature sensor prior eliminating the need to run the boiler. Set the heating delay in accordance with system conditions.



If this setting is enabled, the DHW demand signal is no longer available → page 50.

The start delay can be set between 00 to 50 (0 to 50 seconds) in increments of 1 second.

Default setting is 00.

Service function C.d: Display current heat demand

Available displays are:

- 00: No heat demand
- 01: Space heating demand present
- 02: DHW heat demand present

12 Gas type conversion



DANGER: Personal injury and property damage

- ▶ This conversion shall only be performed by a trained and certified installer in accordance with the manufacturer's instructions and all applicable codes and requirements of the authority having jurisdiction.
- ▶ If the information in these instructions is not followed exactly, or the installation, adjustment, modification, operation or maintenance is carried out by an unqualified person, a fire, explosion or generation of large amounts of carbon monoxide may result in property damage, personal injury or loss of life.
- ▶ Before carrying out electrical work: disconnect the installation from the power supply at the emergency shutoff switch or by disengaging the heating system circuit breaker. Take measures to prevent accidental reconnection.
- ▶ The installer is responsible for the proper conversion of this appliance.
- ▶ The conversion is not complete until the operation of the converted appliance is checked as specified in these instructions.

Adjustment to different flue systems using throttle discs or baffles is not necessary.

NG

- Appliances are set at the factory to Wobbe index 1,333 BTU/ft³ (49.6 MJ/m³) at 60 °F (15 °C), 30" Hg (1016 hPa) and 7.0" W.C. (17.4 mbar) gas supply pressure and sealed.

Converting to a different gas type



DANGER: Explosion!

- ▶ Close the gas cock prior to working on the gas train.
- ▶ Check for gas leaks after working on the gas train.

A gas conversion kit is included in the scope of delivery.

- ▶ Swing the Heatronic boiler control to the left.
- ▶ Check the number on the code plug from the gas conversion kit:

Appliance	NG Code plug	LPG Code plug & fixed gas throttle	Ø
	Order number	Order number	
KBR16-3A	8 714 432 501 0	8 714 432 506 0	3.8
KBR21-3A	8 714 432 528 0	8 714 432 529 0	4.9
KBR28-3A	8 714 432 502 0	8 714 432 507 0	4.9
KBR35-3A	8 714 432 503 0	8 714 432 508 0	5.6
KBR42-3A	8 714 432 504 0	8 714 432 509 0	5.6
KWB28-3A	8 714 432 520 0	8 714 432 521 0	4.9
KWB35-3A	8 714 432 524 0	8 714 432 525 0	5.6
KWB42-3A	8 714 432 500 0	8 714 432 505 0	5.6

- ▶ Replace the code plug in the Heatronic with the code plug from the gas conversion kit.

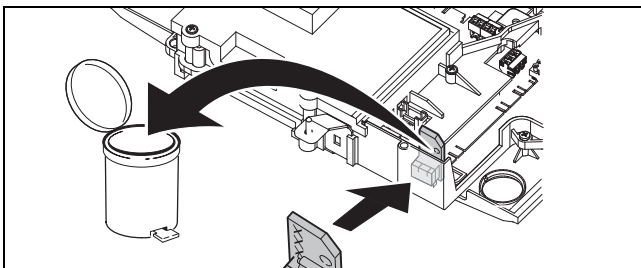

Fig. 71 Replacing the code plug

1. Loosen the pipe connection
2. Loosen the gas/air premix chamber
3. Remove the gas pipe with the premix chamber

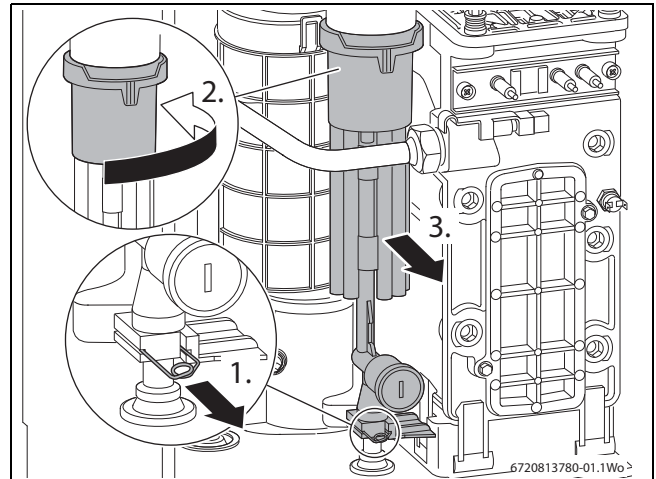

Fig. 72

- ▶ Fit the fixed gas throttle for LPG

-or-

- ▶ Remove the fixed gas throttle for NG

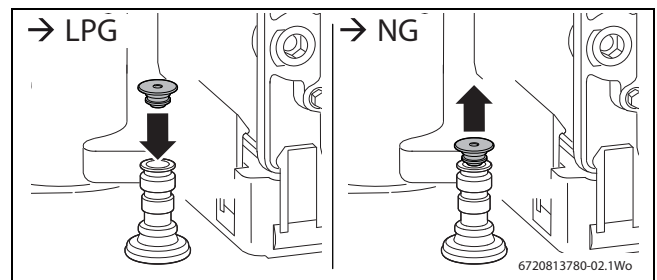

Fig. 73

- ▶ Re-fit the gas pipe with gas/air premix chamber
- ▶ Reconnect the gas pipe connection



With these conversions there is no setting of the air/gas ratio (CO₂ or O₂) required

- ▶ Affix the gas type label from the gas conversion kit to the original gas type label covering the original gas type information located at the bottom of the original gas type label.

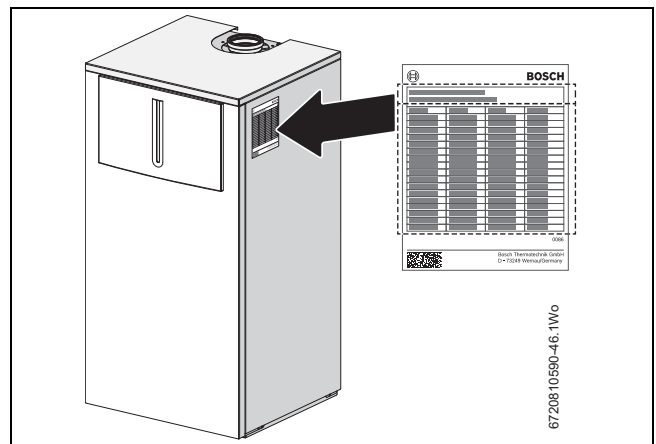

Fig. 74 Attaching the rating plate



The Bosch Greenstar boiler is factory set for installation below 2000 feet (610 m) above sea level.

12.1 Installation location higher than 2,000 feet (610 m) above sea level

Input and output rates are reduced at higher altitudes due to thin air with reduced oxygen levels.

KBR42-3A... and KWB42-3A... appliances are derated at 3 % per 1000 feet (305 m).

KBR30-3A and KWB30-3A appliances offer altitude adjustment which compensates for the effects of thin air, and are therefore NOT derated up to 6000 feet (1829 m). Above 6000 feet (1829 m) a rate of 3% per 1000 feet (305 m) applies.



The Bosch Greenstar boiler is factory set for installation below 2000 feet (610 m) above sea level.

- ▶ Correction of the fan speed curve of the burner:
Use service function 0.d to adjust the elevation setting (→ page 57).

12.2 Setting the gas-air ratio (CO₂ or O₂)

The gas-air ratio must always be set on the basis of a CO₂ or O₂ reading taken at maximum nominal output and minimum nominal output using an electronic flue gas analyzer.

Adjustment to different flue systems using throttle discs or baffles is not necessary.

- ▶ Switch the appliance OFF using the ON/OFF switch.
- ▶ Remove the cover (→ page 33).
- ▶ Switch the appliance ON using the ON/OFF switch.
- ▶ Unscrew a plug, indicated in the figure below, to open one of the flue gas test ports.

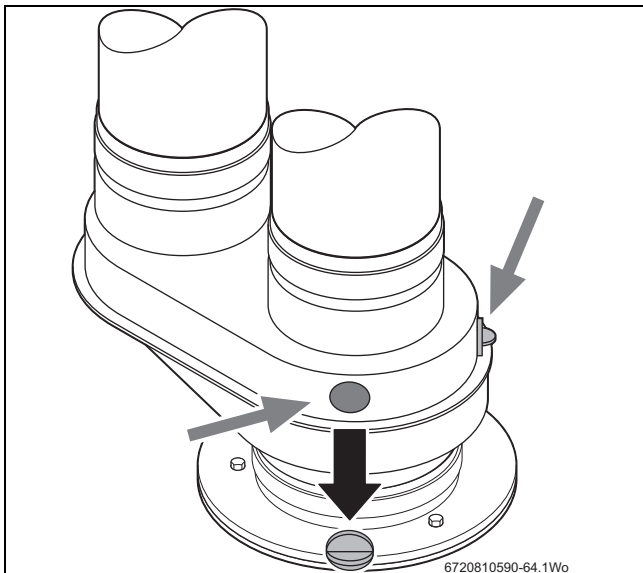

Fig. 75 Open one of the flue gas test ports

- ▶ Insert the probe approximately 2-3/4 inches (70 mm) into the test port and seal around it.
- ▶ Press and hold the emissions test button until it lights up. The display shows the supply temperature alternating with = **maximum set output in heating mode.**

- ▶ Briefly press the emissions test button . The display shows the supply temperature in alternation with = **maximum nominal output.**
- ▶ Measure the CO₂ or O₂ level and the CO content of the flue gas (→ Section 13).
- ▶ On the gas throttle, break the seal at the slot and remove the cap.

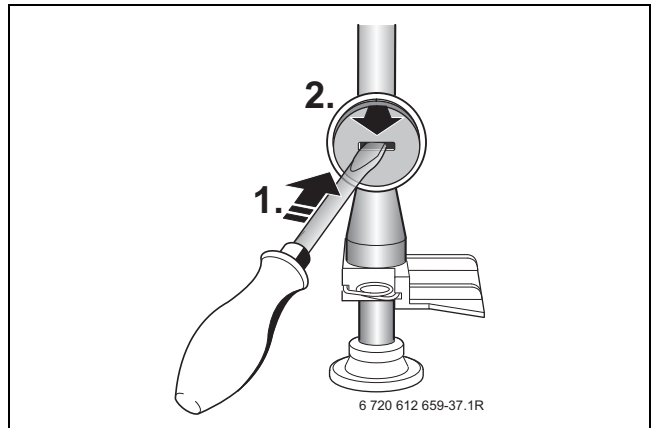

Fig. 76 Remove seal from the gas throttle

- ▶ Adjust the gas throttle to match the CO₂ or O₂ level for maximum nominal output according to table 23.

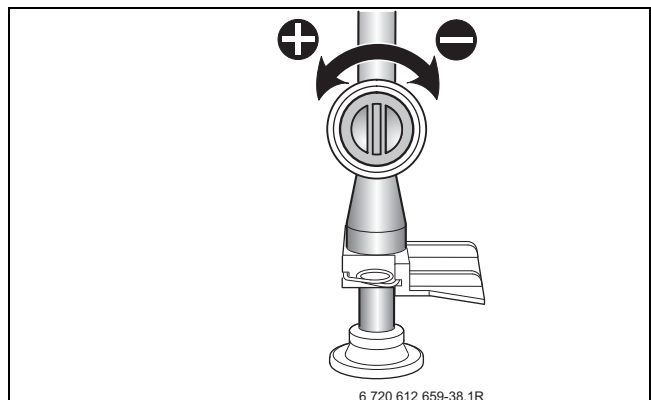

Fig. 77 Set CO₂ or O₂ level for maximum nominal output

Gas type	Maximum nominal output		Minimum nominal output	
	CO ₂	O ₂	CO ₂	O ₂
NG	9.4 %	4.0 %	8.6 %	5.5 %
LPG (propane)	11.0 %	4.2 %	10.4 %	5.1 %

Table 23 CO₂ or O₂ values at maximum and minimum nominal output

- ▶ Briefly press the emissions test button . The display shows the supply temperature in alternation with = **minimum nominal output.**
- ▶ Measure the CO₂ or O₂ level and the CO content of the flue gas (→ Section 13).

- ▶ Remove the sealed screw (→ Fig. 78, [3]) from gas valve adjustment screw (→ Fig. 78, [2]) and set CO₂ or O₂ level for minimum nominal output.

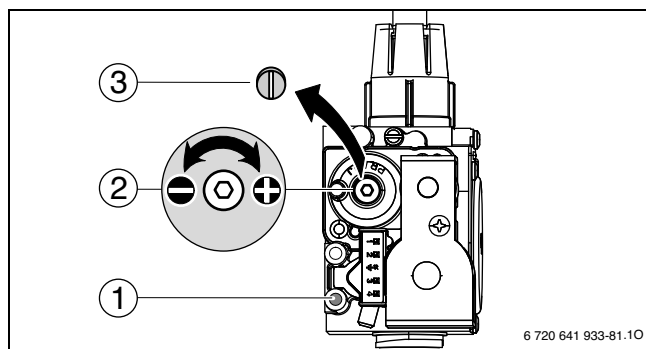



Fig. 78 Set CO₂ or O₂ level for minimum nominal output

- [1] Gas inlet pressure test point
- [2] Minimum adjustment screw
- [3] Minimum adjustment screw cover

- ▶ Re-check settings at maximum and minimum nominal output and re-adjust if necessary.
- ▶ Repeatedly press the emissions test button  until the light goes out. The display returns to the supply temperature.
- ▶ Record the CO₂ or O₂ levels and the CO content of the flue gas in the commissioning log.
- ▶ Reinstall the screw (→ Fig. 78, [3]) to cover the gas valve adjustment screw.
- ▶ Remove flue gas probe and refit the plug into the flue gas test port and tighten to secure.

12.3 Dynamic gas pressure test

- ▶ Switch the appliance OFF and close the gas shut-off valve.
- ▶ Loosen the screw in the test port for gas inlet pressure (→ Fig. 78, [1]) and connect a pressure gauge (→ Fig. 79).

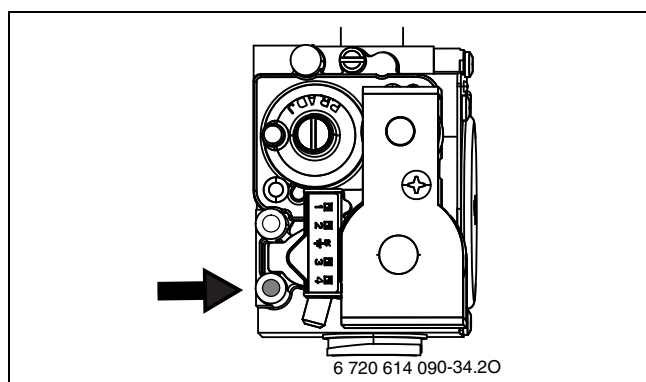





Fig. 79 Dynamic gas pressure test port

- ▶ Turn on the gas cock and switch the appliance ON.
- ▶ Press and hold the emissions test button  until it lights up. The display shows the supply temperature alternating with  = **maximum set output in heating mode**.
- ▶ Briefly press the emissions test button . The display shows the supply temperature in alternation with  = **maximum nominal output**.
- ▶ Check the required inlet gas pressure according to table 24.

Gas type	Nominal pressure " W.C. (mbar)	Permissible pressure range for maximum nominal output " W.C. (mbar)
NG	7 (17.4)	3.5-10.5 (8.7-26.1)
LPG (propane)	11 (27.4)	8-13 (19.9-32.3)

Table 24 Inlet gas pressure



Do not operate the appliance if the measured value is below or above these values. Determine the cause and eliminate the fault. If this is not possible, block the appliance on the gas side and notify the gas supplier.

- ▶ Press the emissions test button  until the light goes out. The display returns to the supply temperature.
- ▶ Switch the appliance OFF, turn off the gas cock, remove the pressure gauge and tighten the screw in the test port for gas inlet pressure.
- ▶ Reinstall the cover.

13 Flue gas test

13.1 Emissions test button

The following appliance outputs can be selected by pressing the emissions test button  until it lights up:

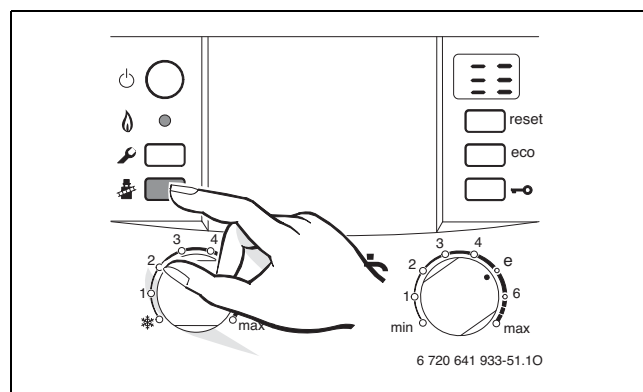





Fig. 80 Press the emissions test button

-  = Maximum set output in heating mode (à Maximum heating output, page 54)
-  = Maximum nominal output
-  = Minimum nominal output



You have 15 minutes to complete the tests. After that, the appliance returns to default mode.

13.2 Measuring CO content of flue gas

Use a multiport flue gas probe for the measurements.

- ▶ Open one of the flue gas test ports (→ Fig. 75).
- ▶ Insert the flue gas probe approx. 2-3/4 inches (70 mm) into the test port and seal around it.
- ▶ Press the emissions test button to select  = **maximum nominal output**.
- ▶ Measure the CO levels.



DANGER: Risk of flue gas poisoning.
The CO level in the flue gas must be below 200 ppm (air free).

- ▶ If 9.4 Vol.%¹⁾ CO₂ and a CO level under 200 ppm (af) can not be achieved due to the gas supplied, use a lower CO₂ level with CO emissions under 200 ppm (af) instead.

1) 9.4 Vol.% with NG and 11.0 Vol.% with LPG (propane)

- ▶ Repeatedly press the emissions test button  until the light goes out.
The display returns to the supply temperature.
- ▶ Remove flue gas probe and close the flue gas test port properly.

14 Environmental responsibility/disposal

Environmental responsibility is one of the fundamental company policies of the Bosch Group.

We regard quality of performance, economy and environmental responsibility as equal objectives. Environmental protection laws and regulations are strictly adhered to.

To protect the environment, we use the best possible technology and materials taking into account economic points of view.

Packaging

All packaging materials used are environmentally-friendly and recyclable.

Old appliances

Old appliances contain resources that must be submitted for recycling. The components are easy to separate and the plastics are marked. This allows the various components to be sorted for appropriate recycling or disposal.

15 Inspection and maintenance

Annual service and maintenance is required for a long service life of the appliance, for efficient and economical operation, and to keep the environmental impact as low as possible. Owners/operators are encouraged to sign a service and maintenance contract with a trained and certified installer for annual servicing and maintenance of the boiler.



DANGER: Explosion!

- ▶ Close the gas cock prior to working on the gas train.
- ▶ Check for gas leaks after carrying out work on the gas train.



DANGER: Risk of flue gas poisoning.

- ▶ Check for leaks after carrying out work on the venting system.



DANGER: Risk of electric shock!

- ▶ Always disconnect the appliance from the mains power before performing any work. Disconnect the emergency shutoff switch or disengage the heating system circuit breaker. Take measures to prevent accidental re-connection.

NOTICE: Insufficient antifreeze can accelerate corrosion.

- ▶ Frost protection level has to be checked annually during the regular scheduled maintenance of the condensing boiler.

Heat exchanger

NOTICE: Damage to the coating of the heat exchanger.

- ▶ Cleaning of the heat exchanger should not be necessary until five years after the initial commissioning.
- ▶ Only use a Bosch cleaning blade or Bosch cleaning brush (→ page 65).
- ▶ Only clean heat exchanger if soiling is clearly visible.

Heatronic boiler control

In case of a component defect, a fault is shown on the display. The Heatronic boiler control monitors all safety and control components.

NOTICE: The Heatronic boiler control can be damaged by leaking water.

- ▶ Cover the Heatronic prior to working on water filled components.

Notes on installation and operation



An overview of the faults can be found on page 71.

- The following analytical tools are needed for service and maintenance:
 - Electronic flue gas analyzer for CO₂, O₂, CO, and flue gas temperature
 - Pressure gauge 0 to 12 inches W.C. (0 to 30 mbar)
 - pH Test strips
 - Glycol tester of antifreeze is being used
- Special tools are not required.
- Approved lubricants are:
 - For parts touched by water: Unisilikon L 641 (part-# 8 709 918 413 0)
 - or fittings: HFt 1 v 5 (part-# 8 709 918 010 0).
- ▶ Use part-# 8 719 918 658 0 as heat conducting paste.
- ▶ Use only genuine Bosch spare parts.
- ▶ Request spare parts (→ Section 19, page 77).
- ▶ Replace removed gaskets and O-rings with new ones.

After the inspection/maintenance

- ▶ Re-tighten all loosened threaded connections.
- ▶ Restart the appliance (→ page 48).
- ▶ Check all connections for leaks.
- ▶ Check the gas-air ratio and adjust if necessary (→ page 60).

15.1 Description of various steps

15.1.1 Calling up the latest fault (service function 6.A)

- ▶ Select service function **6.A** (→ page 57).



An overview of the faults can be found on page 71.

15.1.2 Fresh water filter (only combi boiler KWB..-3A)

- ▶ Close cold water tap.
- ▶ Depressurize the cold water pipe.
- ▶ To access the filter remove the safety clip (step 1), pull out the pipe (step 2), and remove the filter from the pipe (step 3).
- ▶ If necessary, clean with plastic brush under running water.

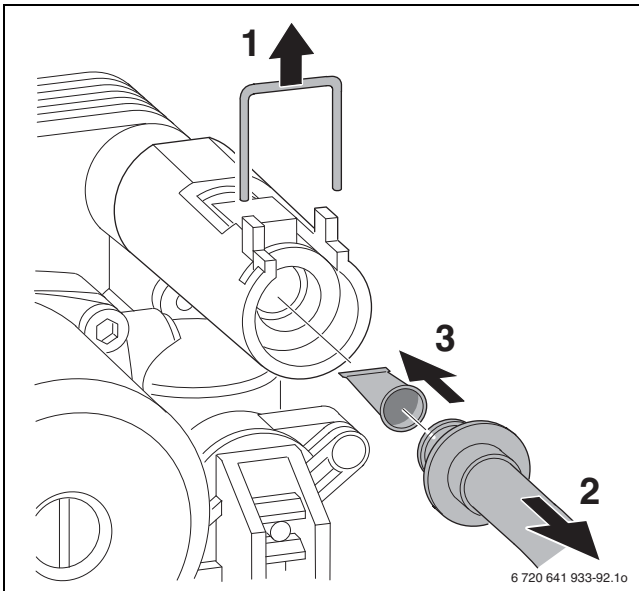

Fig. 81 Filter in fresh water pipe (combi boiler KWB..-3A only)

15.1.3 Plate type heat exchanger (only combi boiler KWB..-3A)

If the DHW output on the combi boiler is significantly reduced:

- ▶ Check filter in the cold water pipe for contamination (→ Fig. 63).
 - ▶ Depressurize the appliance.
 - ▶ Remove the plate type heat exchanger and replace with a new unit.
- or-**
- ▶ Descale with descaling agent approved for stainless steel (Grade 316-1.4401).

To remove the plate type heat exchanger:

- ▶ Unplug electrical connections.
- ▶ Remove hose from safety relief valve.

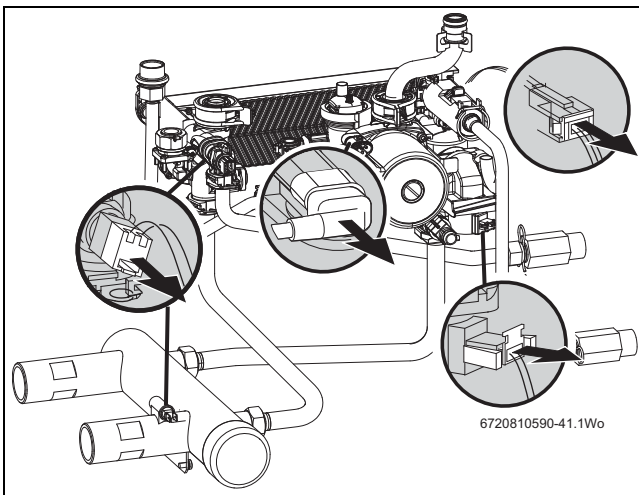

Fig. 82 Unplugging electrical connections / removing hose from PRV

- ▶ Loosen/remove pipe connections.

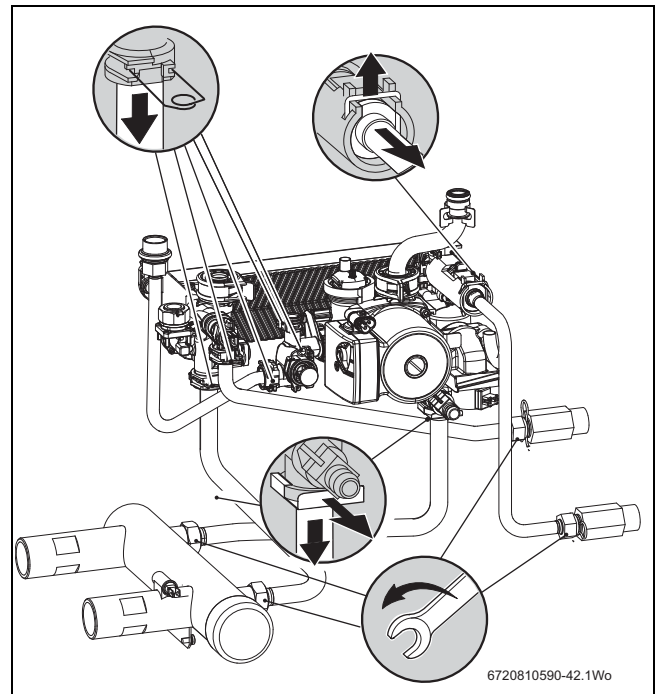

Fig. 83 Removing pipe connections

- ▶ Remove the boiler pressure gauge from the Heatronic boiler control.

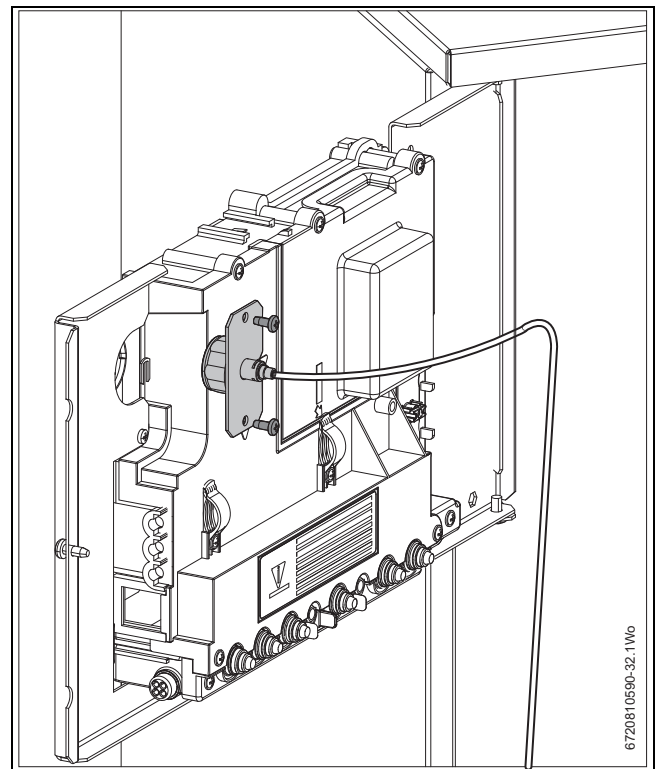

Fig. 84 Removing the boiler pressure gauge

- ▶ Loosen the quick releases (steps 1 and 2) and remove the hydraulic assembly in its entirety (step 3).

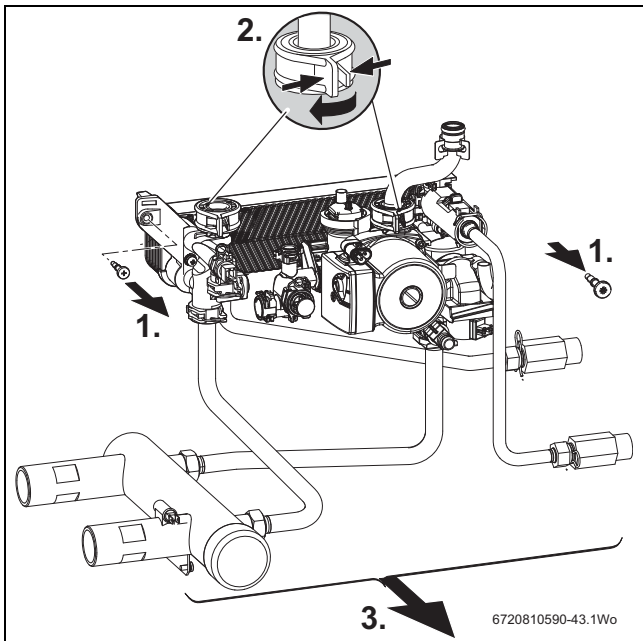

Fig. 85 Removing the hydraulic assembly

- ▶ Remove the plate type heat exchanger.

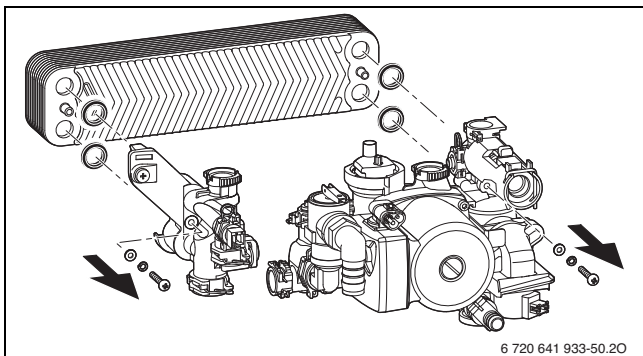

Fig. 86 Removing the plate heat exchanger

- ▶ Install a new plate type heat exchanger with new gaskets and reconnect the hydraulic assembly in reverse order.
- ▶ Check all connections used during maintenance for leaks.

15.1.4 Checking the electrodes

- ▶ Remove the electrode set (→ page 8 / 10) including gasket and check the electrodes for contamination; clean or replace, as required.
- ▶ Re-install electrode set with new gaskets and check for leaks.

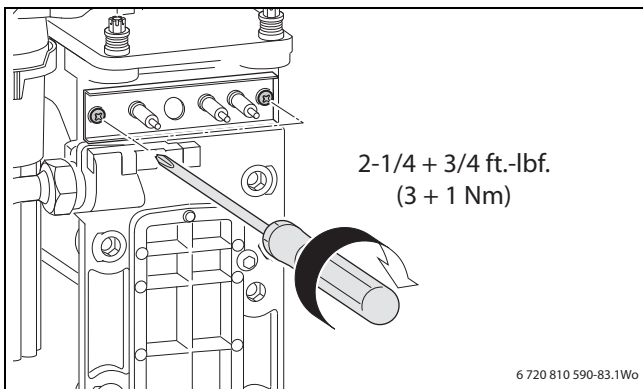

Fig. 87 Reinstalling the electrode set

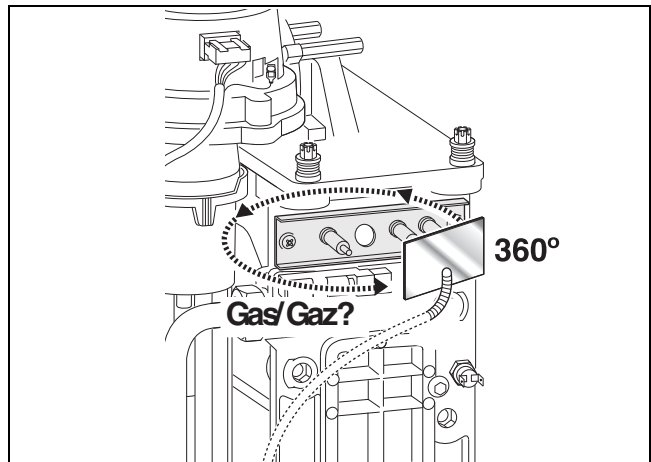

Fig. 88 Check for gas leaks

15.1.5 Burner servicing

! DANGER: Fire danger!
▶ Only operate the burner while installed in a boiler.

- ▶ Remove the burner cover (steps 1 - 4).

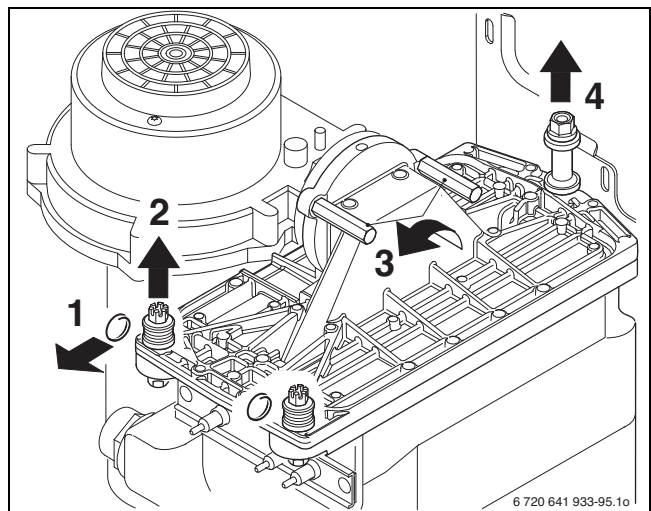

Fig. 89 Removing the burner cover

- ▶ Remove the burner and clean the components.

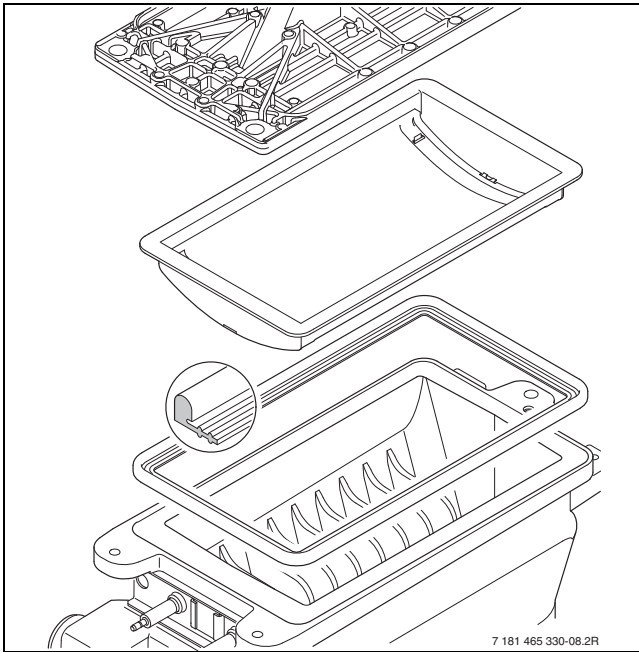

Fig. 90 Burner

- ▶ Reinstall the burner in reverse order, including a new gasket.
- ▶ Adjust the gas-air ratio (→ page 60).

15.1.6 Heat exchanger block inspection and cleaning

NOTICE: Damage to the coating of the heat exchanger.

- ▶ Cleaning of the heat exchanger should not be necessary until five years after the initial commissioning.
- ▶ Only use a Bosch cleaning blade and Bosch cleaning brush (→ page 66).
- ▶ Only clean heat exchanger in case if soiling is clearly visible.

- ▶ Remove the inspection cover (→ page 8) and any sheet metal insert below, if installed.
- ▶ Determine degree of soiling of the heat exchanger through visual inspection.

If mechanical cleaning is required:

For cleaning the heat exchanger, use Bosch main heat exchanger gaskets, the heat exchanger brush and the heat exchanger cleaning blade which are available as spare parts.

- ▶ Remove the condensate trap (steps 1 and 2) and place a suitable container underneath.

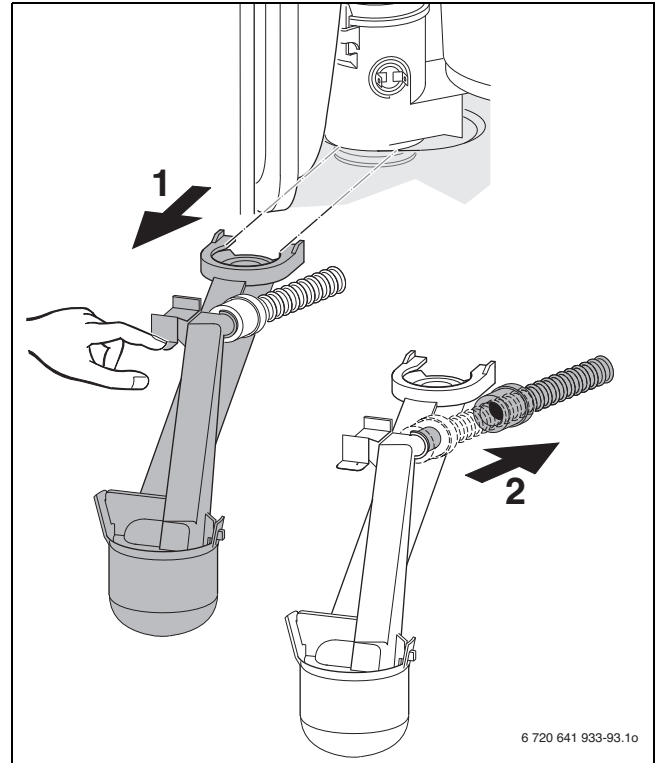

Fig. 91 Removing the condensate trap

- ▶ With the cleaning blade, clean the heat exchanger block from the bottom to the top.

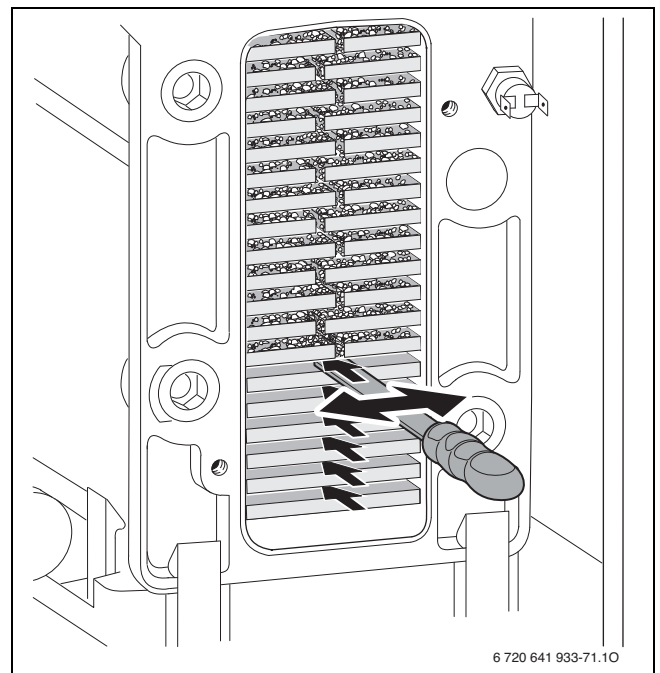

Fig. 92 Cleaning the heat exchanger with the cleaning blade

- ▶ Clean the heat exchanger block with the brush from top to bottom.

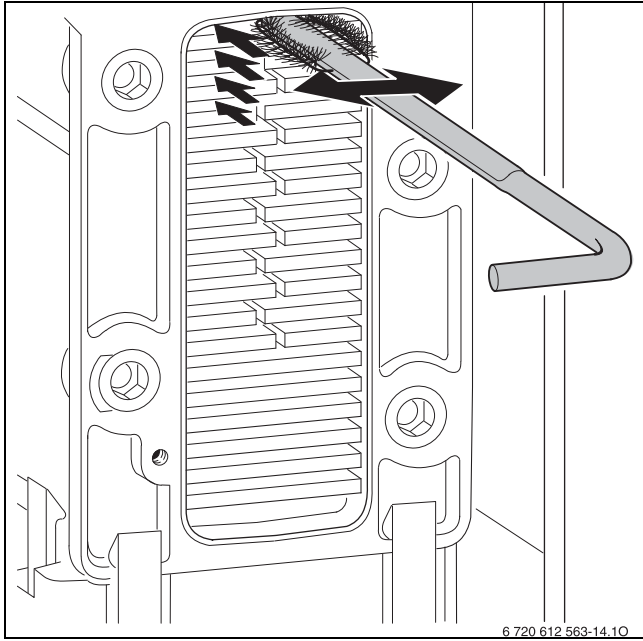

Fig. 93 Cleaning the heat exchanger with the cleaning brush

- ▶ Remove burner (→ Chapter 15.1.5 “Burner servicing”).
- ▶ Rinse the heat exchanger with water from the top.

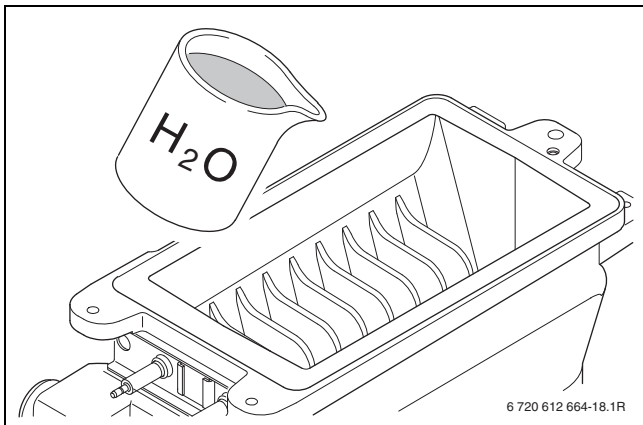

Fig. 94 Rinsing the heat exchanger

- ▶ Clean the condensate tray (with reversed brush).

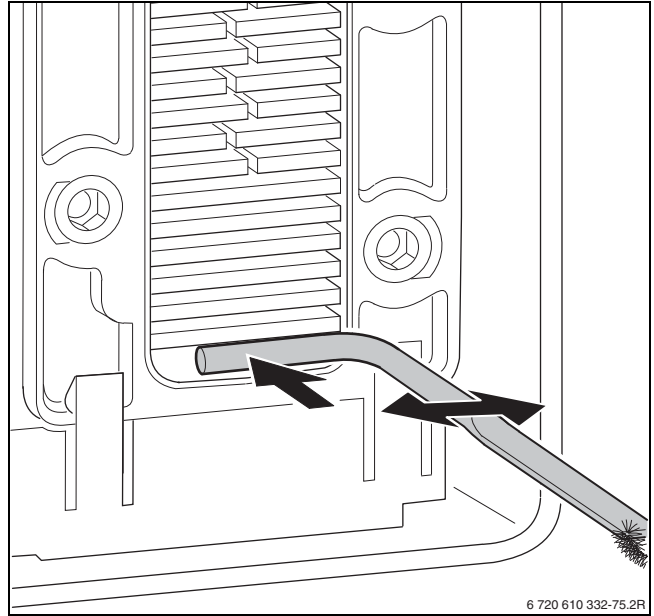

Fig. 95 Cleaning the condensate tray

- ▶ Rinse the heat exchanger with water from the top.
- ▶ Clean the condensate trap connection.
- ▶ Close the inspection opening again using a new gasket and tighten the screws with approx. 3.69 ft.-lbf. (5 Nm).

15.1.7 Condensate trap cleaning

- ▶ Remove the condensate trap (steps 1 and 2) and check that the heat exchanger has a clear passage.

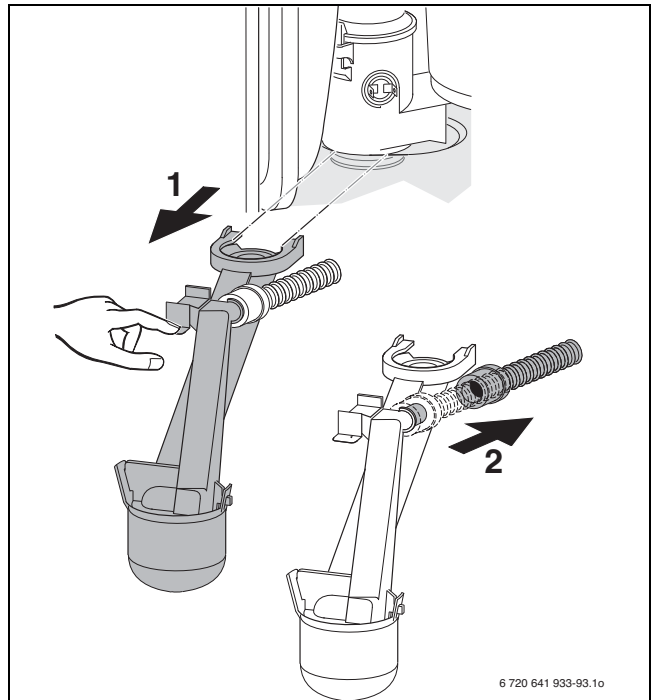

Fig. 96 Removing the condensate trap

- ▶ Remove and clean the condensate trap lid.
- ▶ Check condensate the hose and clean if necessary.
- ▶ Fill the condensate trap with approximately 1 cup (1/4 litre) of water and reinstall it.

15.1.8 Checking the mixer diaphragm

- ▶ Open the mixer unit.
- ▶ Carefully remove the diaphragm from the fan air intake and check for contamination and cracks.

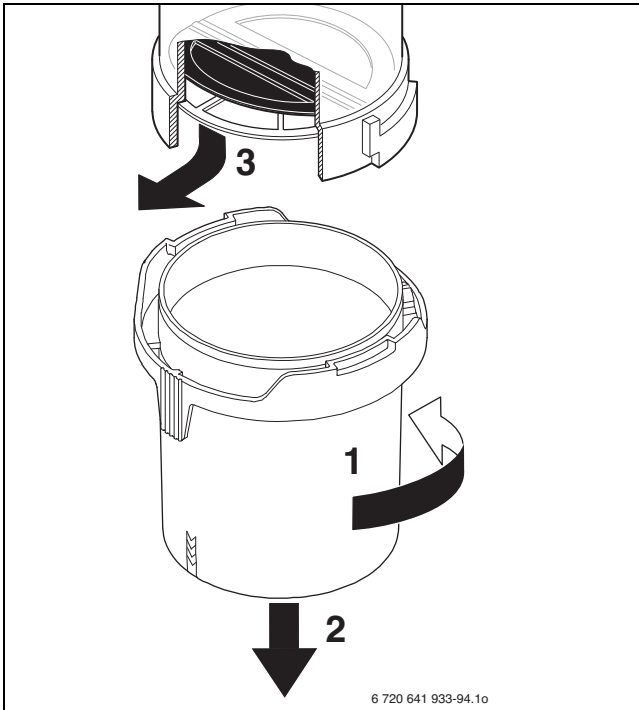

Fig. 97 Opening the mixer unit

- ▶ Insert the diaphragm into the fan connector. Ensure the diaphragm is oriented properly.



The diaphragm flaps must open upwards.

- ▶ Close the mixer unit.

15.1.9 Expansion vessel



DANGER: Risk of electric shock!

- ▶ Always disconnect the appliance from the mains power before performing any work. Disconnect the emergency shutoff switch or disengage the heating system circuit breaker. Take measures to prevent accidental re-connection.

Annual inspection of the expansion vessel is required.

- ▶ Depressurize the appliance.
- ▶ If necessary, adjust the expansion vessel pre-charge pressure to the static head of the heating system (→ page 31).

15.1.10 Setting the boiler water pressure

Display on the pressure gauge	
14.5 psi (1 bar)	Minimum filling pressure (when system is cold)
14.5 psi to 21.75 psi (1 bar to 1.5 bar)	Optimal filling pressure
30 psi (2.07 bar)	Maximum pressure at maximum heating water temperature must not be exceeded (safety valve will spill).

Table 25 Operating pressure

- ▶ If the indicator is below 14.5 psi (1 bar) when the system is cold, top up the water. The indicator must be between 14.5 psi (1 bar) and 21.75 psi (1.5 bar).



If using a hose to fill the heating system, prefill the hose with water to prevent air being introduced into the system.

- ▶ If the pressure is not held, check the expansion vessel and heating system for leaks.

15.1.11 Testing system water quality

- ▶ Take a representative sample of the system water and analyze pH using a pH meter or pH test strips.

pH-value	Water preparation
7-8.5	Not needed
4.5-7	Required

Table 26 Water preparation for filling and maintaining the heating system (pH-value)

- ▶ If the value is outside of the permitted range, drain the system, flush, and refill with fresh water to prevent system damage or leaks.
- ▶ If the fill water does not meet the requirements of page 30, treat the water to bring it within the permissible range.
- ▶ If antifreeze is being used in the system, check the frost protection properties to ensure the site specific requirements are met.

15.1.12 Inspecting electrical wiring

- ▶ Check electrical wiring for mechanical damage and replace defective cables.

15.2 Checklist for annual inspection and maintenance

- Use this form to guide you through the service and maintenance procedure. Fill out each step according to the findings and work performed.

Date →					
1	Latest fault code from service function 6.A (→ page 62).				
2	Fresh water inlet filter (Combi boiler KWB appliances only) (→ page 63).				
3	Visual inspection of the combustion air pipes and vent pipes.				
4	Dynamic gas pressure (→ page 61).	inches W.C. (mbar)			
5	Gas-air ratio at min./max. nominal output (→ page 60).	min. % max. %			
6	Gas and water-side leak test (→ page 43).				
7	Inspect electrodes (→ page 64).				
8	Inspect heat exchanger block (→ page 65).				
9	Check burner (→ page 64).				
10	Inspect diaphragm in mixer unit (→ page 67).				
11	Clean condensate trap (→ page 66).				
12	With the system depressurized, check the expansion vessel pre-charge pressure vs. the static head of the heating system.	psi (bar)			
13	Check the heating system filling pressure.	psi (bar)			
14	Inspect electrical wiring for damage.				
15	Check settings of the heating control.				
16	Check set service functions according to commissioning report (→ page 75).				

Table 27 Maintenance and inspection checklist

16 Readings on the display

The boiler display can provide the following information (Tab. 28 and 29):

Value displayed	Description	Range
Number or letter, dot followed by letter	Service function (→ Tab. 20 / 21, page 53)	
Letter followed by number or letter	Fault code (→ Tab. 30, page 71) (exception: b.A = service function)	
Three numbers (≤ 199)	Decimal value, e.g. supply temperature	00..199
One number (displayed for longer) followed by two numbers (displayed briefly)	Decimal figure (three digits); first digit is shown alternating with two last digits (e.g. 2.69..69 for 269)	0..999
Two dashes followed by two pairs of numbers	Code is shown in three stages: 1. Two dashes 2. First two digits 3. Last two digits (e.g. -- 10 04)	1000 ... 9999
Two letters followed by two pairs of numbers	Code is shown in three stages: 1. Two letters 2. First two digits 3. Last two digits (e.g. CF 10 20)	

Table 28 Display readings

Status code	Description
	Acknowledge by pressing any button (except reset).
	Acknowledge by pressing two buttons simultaneously
	Acknowledge by pressing and holding for more than 3 seconds (Save function).
	The display shows the supply temperature in alternation with . The appliance works for 15 minutes at the minimum nominal output, → service function 2.F .
	The display shows the supply temperature in alternation with . The appliance works with the set maximum output in heating mode, → service function 1.A .
	The display shows the supply temperature in alternation with . The appliance works for 15 minutes at the maximum nominal output, → service function 2.F .
	The air purging function is active, → service function 2.C
	The display shows the supply temperature in alternation with . The trap filling sequence is active, → service function 4.F .
	The display shows the supply temperature alternating with . Service reminder, → service function 5.A .
	The display shows the supply temperature in alternation with . The pump may have seized, → fault E.9 .
	The display shows the supply temperature in alternation with . The temperature gradient limiter was triggered. Excessive supply temperature increase: Heating mode is suspended for two minutes.
	Slab drying function of the FW200 weather compensation control (→ operating instructions) or building drying function (→ service function 7.E) are activated.
	Key pad lock enabled. To unlock the key pad, press until the supply temperature is shown on the display.

Table 29 Special displays

17 Faults

17.1 Troubleshooting



DANGER: Explosion!

- ▶ Close the gas cock prior to working on the gas train.
- ▶ Check for gas leaks after carrying out work on the gas train.



DANGER: Risk of flue gas poisoning.

- ▶ Check for leaks after carrying out work on the venting system.



DANGER: Risk of electric shock!

- ▶ Always disconnect the appliance from the mains power before performing any work. Disconnect the emergency shutoff switch or disengage the heating system circuit breaker. Take measures to prevent accidental re-connection.



WARNING: Danger of scalding!

Hot water can scald.

- ▶ Drain the appliance before working on components that are water filled.

NOTICE: The Heatronic boiler control can be damaged by leaking water.

- ▶ Cover the Heatronic prior to work on water filled components.

The Heatronic boiler control monitors all safety and control components.

If a fault arises during operation, an audible warning tone sounds.



Press a button to mute the warning sound.

The display indicates a fault code (e.g. EA) and the reset button flashes.

If the reset button is flashing:

- ▶ Press the reset button and hold it until – – appears on the display. The appliance starts up again and the current supply temperature is displayed.

If the reset button is not flashing:

- ▶ Switch the appliance OFF and ON again. The appliance starts up again and the current supply temperature is displayed.



An overview of the faults can be found on page 71.
An overview of the status codes can be found on page 69.

If the fault persists:

- ▶ Check the PCB and replace if required. Adjust the service functions in accordance with the commissioning report (→ page 75).

17.2 Faults that are shown on the display

Display	Description	Elimination
A7	DHW temperature sensor defective.	<ul style="list-style-type: none"> ▶ Check temperature sensor and leads for interruptions or shorts, and replace if defective. ▶ Insert code plug correctly; replace if defective.
A8	Communication fault.	<ul style="list-style-type: none"> ▶ Check BUS communications wiring, replace if defective. ▶ Check control, replace if defective.
Ad	DHW tank temperature not detected. The DHW tank temperature sensor was recognized before the connection was lost.	<ul style="list-style-type: none"> ▶ Check DHW tank temperature sensor and connecting lead, replace if defective. ▶ Reset the boiler to the factory default settings (→ service function 8.E), reset the IPM 2 (if installed) to the factory default settings and carry out the automatic system configuration.
b1	Code plug not detected.	<ul style="list-style-type: none"> ▶ Insert code plug correctly; replace if defective.
b2/ b3/ b4/ b5/ b6	Internal data error.	<ul style="list-style-type: none"> ▶ Reset boiler to factory default setting (→ service function 8.E).
b7	Fault in the burner controls.	<ul style="list-style-type: none"> ▶ Reset boiler to factory to default setting (→ service function 8.E).
C6	Fan not running.	<ul style="list-style-type: none"> ▶ Check fan leads and fan, replace if defective.
CC	Outdoor temperature sensor not recognized.	<ul style="list-style-type: none"> ▶ Check outdoor temperature sensor and leads for interruptions, replace if defective. ▶ Verify the outdoor temperature sensor is connected to 3 (Out Sen) on the terminal block in the low voltage junction box.
d3	Temperature high limit defective. External guard has tripped. Temperature limiter locked out.	<ul style="list-style-type: none"> ▶ Check temperature sensor and leads for interruptions or shorts, and replace if defective. ▶ Temperature guard TB1 has tripped. Check if jumper across 8-9 or PR-P0 is missing. ▶ Reset external temperature limiter (if installed).Reset LWCO (if installed).
d5	External supply temperature sensor defective (low-loss header). The external supply temperature sensor was recognized on the BUS and then reconnected to the appropriate terminal.	<ul style="list-style-type: none"> ▶ Check temperature sensor and leads for interruptions or shorts, and replace if defective. ▶ Check whether only one temperature sensor is connected; otherwise remove second temperature sensor. ▶ Reset the boiler to the factory default settings (→ service function 8.E), reset the IPM 2 (if installed) to the factory default settings and carry out the automatic system configuration.
E2	Supply temperature sensor defective.	<ul style="list-style-type: none"> ▶ Check temperature sensor and leads for interruptions or shorts, and replace if defective.
E3	Additional supply temperature sensor defective.	<ul style="list-style-type: none"> ▶ Check temperature sensor and leads for interruptions or shorts, and replace if defective.
E9	Heat exchanger safety high limit or flue gas temperature limiter has tripped.	<ul style="list-style-type: none"> ▶ Check flue gas safety high limit and leads for interruptions or shorts, and replace if defective. ▶ Check heat exchanger safety high limit and leads for interruptions or shorts, and replace if defective. ▶ Check the operating pressure. ▶ Check temperature limit; replace if defective. ▶ Check pump capacitor; replace pump if defective. ▶ Check PCB fuse, replace if blown (6.3 A fuse according to IEC default). ▶ Purge the appliance ▶ Check heat exchanger on the DHW side; replace if clogged.

Table 30 Faults shown on the display

Display	Description	Elimination
EA	No flame detected. GFA: Safety time expired.	<ul style="list-style-type: none"> ▶ Check that ground lead is properly connected, replace if defective. ▶ Check that gas cock is open. ▶ Check inlet gas pressure; correct if needed. ▶ Check power supply. ▶ Check electrodes for visual damage; replace if defective. ▶ Check flue gas system; clean or repair if defective. ▶ Check gas/air ratio; correct if out of range. ▶ Check gas valve; replace if defective. ▶ In room air operation, check air supply or ventilation apertures. ▶ Clean the condensate trap. ▶ Remove diaphragm at fan inlet connection and check for contamination or cracks. ▶ Check heat exchanger for soiling (→ Chapter 15.1.6, page 65). ▶ Check gas cock; replace if defective. ▶ Insert code plug correctly; replace if defective.
F0	Internal fault	<ul style="list-style-type: none"> ▶ Press reset for 3 seconds and release. When the button is released, the appliance will restart. ▶ Check electrical plug-in contacts and ignition leads; replace PCB if defective. ▶ Check gas/air ratio; correct if out of specification.
F1	Internal data error.	<ul style="list-style-type: none"> ▶ Reset boiler to the factory default setting (→ service function 8.E).
F7	Flame detected even when burner is off.	<ul style="list-style-type: none"> ▶ Check electrodes; replace if defective. ▶ Check flue gas system; clean or repair if defective. ▶ Check PCB for moisture; dry if needed.
FA	After switching gas off: Flame is detected.	<ul style="list-style-type: none"> ▶ Check gas cock; replace if defective. ▶ Clean condensate trap. ▶ Check electrodes and leads; replace if defective. ▶ Check flue gas system; clean or repair if needed.
Fd	Reset button pressed by mistake.	<ul style="list-style-type: none"> ▶ Press reset button again. ▶ Check cable harness to safety high limit and gas cock for ground connection.
	Temperature gradient limiter: Temperature rise too fast	<ul style="list-style-type: none"> ▶ Fully open service shut-off valves. ▶ Check electrical connection between heating zone pump and Heatronic. ▶ Check pump plug connection per installation instructions. ▶ Manually test operation of heating zone pump and replace if defective. ▶ Set pump speed correctly to match maximum output.

Table 30 Faults shown on the display

17.3 Faults that are not shown on the display

Appliance faults	Elimination
Combustion noise too loud; rumbling noises	<ul style="list-style-type: none"> ▶ Insert code plug correctly; replace if defective. ▶ Check gas type. ▶ Check inlet gas pressure; adjust if defective. ▶ Check flue gas system; clean or repair if defective. ▶ Check gas/air ratio in the combustion air and flue gas; replace gas valve if defective.
Flow noises	<ul style="list-style-type: none"> ▶ Set pump speed correctly to match maximum output. ▶ Set pump mode.
Heating-up takes too long	<ul style="list-style-type: none"> ▶ Set pump speed correctly to match maximum output. ▶ Set pump mode.
Flue gas readings incorrect; CO levels too high	<ul style="list-style-type: none"> ▶ Check gas type. ▶ Check inlet gas pressure; adjust if defective. ▶ Check flue gas system; clean or repair if defective. ▶ Check gas/air ratio in flue gas; replace gas valve if defective.
Violent ignition, poor ignition	<ul style="list-style-type: none"> ▶ Check gas type. ▶ Check inlet gas pressure; adjust if defective. ▶ Check power supply. ▶ Check electrodes for visual damage; replace if defective. ▶ Check flue gas system; clean or repair if defective. ▶ Check gas/air ratio; replace gas valve if defective. ▶ Check gas valve; replace if defective. ▶ Check burner; replace if required.
DHW has unpleasant odor or has a dark color	<ul style="list-style-type: none"> ▶ Perform thermal disinfection of the DHW circuit. ▶ Replace sacrificial anode in the tank (if installed). ▶ Consult local water department.
Set supply temperature (e.g. of the FW200 control) exceeded	<ul style="list-style-type: none"> ▶ Switch off automatic anti-cycle timer, i.e., set value to 0. ▶ Set the required anti-cycle timer, e.g. default setting of 3 minutes.
Condensate in air box	<ul style="list-style-type: none"> ▶ Insert diaphragm in the mixer unit per installation instructions; replace if defective.
DHW temperature is not reached (combi boiler KWB...3A only)	<ul style="list-style-type: none"> ▶ Insert code plug correctly; replace if defective. ▶ Check whether voltage (120 VAC) is present between terminal 1 and terminal 3; repair if defective. ▶ Check turbine; replace if defective.
Heatronic is flashing (i.e. all buttons, all display segments, burner indicator etc. are flashing)	<ul style="list-style-type: none"> ▶ Replace fuse Si 3 (24 V) (6.3 A fuse according to IEC default).

Table 31 Faults not shown on the display

17.4 Check sensor values

17.4.1 Outdoor temperature sensor

Temperature °F (°C) Testing tolerance ± 10%	Resistance [Ω]
- 4 (- 20)	2,392
3 (- 16)	2,088
10 (- 12)	1,811
17 (- 8)	1,562
24 (- 4)	1,342
32 (0)	1,149
39 (4)	984
46 (8)	842
50 (10)	781
59 (15)	642
68 (20)	528
77 (25)	436

Table 32 Resistance table outdoor temperature sensor

17.4.2 Additional supply temperature limiter

Temperature °F (°C) Testing tolerance ± 10%	Resistance [Ω]
32 (0)	33,555
50 (10)	21,232
68 (20)	13,779
86 (30)	9,128
104 (40)	6,205
122 (50)	4,298
140 (60)	3,025
158 (70)	2,176
176 (80)	1,589
194 (90)	1,177
212 (100)	886

Table 33 Resistance table supply temperature limiter

17.4.3 Supply temperature sensor, External supply temperature sensor, DHW tank temperature sensor, DHW temperature sensor

Temperature °F (°C) Testing tolerance ± 10%	Resistance [Ω]
68 (20)	14,772
77 (25)	11,981
86 (30)	9,786
95 (35)	8,047
104 (40)	6,653
113 (45)	5,523
122 (50)	4,608
131 (55)	3,856
140 (60)	3,243
149 (65)	2,744
158 (70)	2,332
167 (75)	1,990
176 (80)	1,704
185 (85)	1,464
194 (90)	1,262
203 (95)	1,093
212 (100)	950

Table 34 Resistance table NTCs

17.5 Replacement code plug

Appliance	Order number
KBR16-3A NG	8 714 432 501 0
KBR16-3A LPG	8 714 432 506 0
KBR21-3A NG	8 714 432 528 0
KBR21-3A LPG	8 714 432 529 0
KBR28-3A NG	8 714 432 502 0
KBR28-3A LPG	8 714 432 507 0
KBR35-3A NG	8 714 432 503 0
KBR35-3A LPG	8 714 432 508 0
KBR42-3A NG	8 714 432 504 0
KBR42-3A LPG	8 714 432 509 0
KWB28-3A NG	8 714 432 520 0
KWB28-3A LPG	8 714 432 521 0
KWB35-3A NG	8 714 432 524 0
KWB35-3A LPG	8 714 432 525 0
KWB42-3A NG	8 714 432 500 0
KWB42-3A LPG	8 714 432 505 0

Table 35 Code plugs for all appliances

18 Commissioning log for the appliance

Home owner/operator:			
Last name, first name		Number, Street	
Telephone/fax		ZIP code, town	
System installer:			
Order number:			
Appliance type: (Complete a separate log for every appliance!)			
FD (Date of manufacture):			
Date commissioned:			
<input type="checkbox"/> Individual appliance			
Installation location: <input type="checkbox"/> Basement <input type="checkbox"/> Attic <input type="checkbox"/> Garage <input type="checkbox"/> other:			
Room air only: Number and size of ventilation openings			ft ² (m ²)
Vent pipe routing: <input type="checkbox"/> Twin pipe system <input type="checkbox"/> Concentric pipe system <input type="checkbox"/> Room air <input type="checkbox"/> Sealed combustion			
<input type="checkbox"/> PVC <input type="checkbox"/> CPVC <input type="checkbox"/> PP <input type="checkbox"/> 2" <input type="checkbox"/> 3"			
Total length: Approx. ft (m) Elbows 90°: Qty Elbows 15 - 45°:Qty			
Flue tightness test completed: <input type="checkbox"/> yes <input type="checkbox"/> no			
CO ₂ value in the combustion air at maximum nominal output:			%
O ₂ value in the combustion air at maximum nominal output:			%
Notes regarding under or over pressure operation:			
Gas setting and flue gas test:			
Gas conversion: <input type="checkbox"/> NG <input type="checkbox"/> LPG (propane)			
Inlet gas pressure	" W.C. (mbar)	Gas static supply pressure:	" W.C. (mbar)
Selected maximum output:	MBH (kW)	Selected minimum output:	MBH (kW)
Gas flow rate at maximum nominal output:	gpm (l/min)	Gas flow rate at minimum nominal output:	gpm (l/min)
Net calorific value H _{IB} (per gas supplier):	MBTU/ft ³ (kWh/m ³)		
CO ₂ at max. nominal output:	%	CO ₂ at minimum nominal output:	%
O ₂ at maximum nominal output:	%	O ₂ at minimum nominal output:	%
CO at maximum nominal output:	ppm	CO at minimum nominal output:	ppm
Flue gas temperature at maximum nominal output:	°F (°C)	Flue gas temperature at minimum nominal output:	°F (°C)
Maximum measured supply temperature:	°F (°C)	Minimum measured supply temperature:	°F (°C)
System hydraulics:			
<input type="checkbox"/> Low-loss header, type:		<input type="checkbox"/> Additional expansion vessel	
<input type="checkbox"/> Low-loss header enabled <input type="checkbox"/> No <input type="checkbox"/> Yes		Size/pre-charge pressure: Automatic air vent present? <input type="checkbox"/> yes <input type="checkbox"/> no	
<input type="checkbox"/> Heating pump:			
<input type="checkbox"/> Primary secondary piping			
<input type="checkbox"/> DHW tank/type/number/heating surface output:			
<input type="checkbox"/> System hydraulics checked, notes:			

19 Spare parts

- Order spare parts by name and part number using the spare parts list.

Designation	KBR16-3	KBR21-3	KWB28-3	KBR35-3	KBR42-3	KWB28-3	KWB35-3	KWB42-3	Spare parts list
Group 1 - Sheet metal	■	■	■	■	■	■	■	■	→ page 79
Group 2 - Burner/Heat exchanger	■	■	■	■	■	■	■	■	→ page 81
Group 3 - Gas valve	■	■	■	■	■	■	■	■	→ page 83
Group 4 - Pipes combi boiler KWB..3A						■	■	■	→ page 85
Group 5 - Pipes heating boiler KBR..3A	■	■	■	■	■				→ page 87
Group 6 - Control box	■	■	■	■	■	■	■	■	→ page 89
Group 7 - Hydraulic block combi boiler KWB..3A						■	■	■	→ page 91
Group 8 - Accessories for service/installation	■	■	■	■	■	■	■	■	→ page 91

Table 36 Spare part groups Greenstar

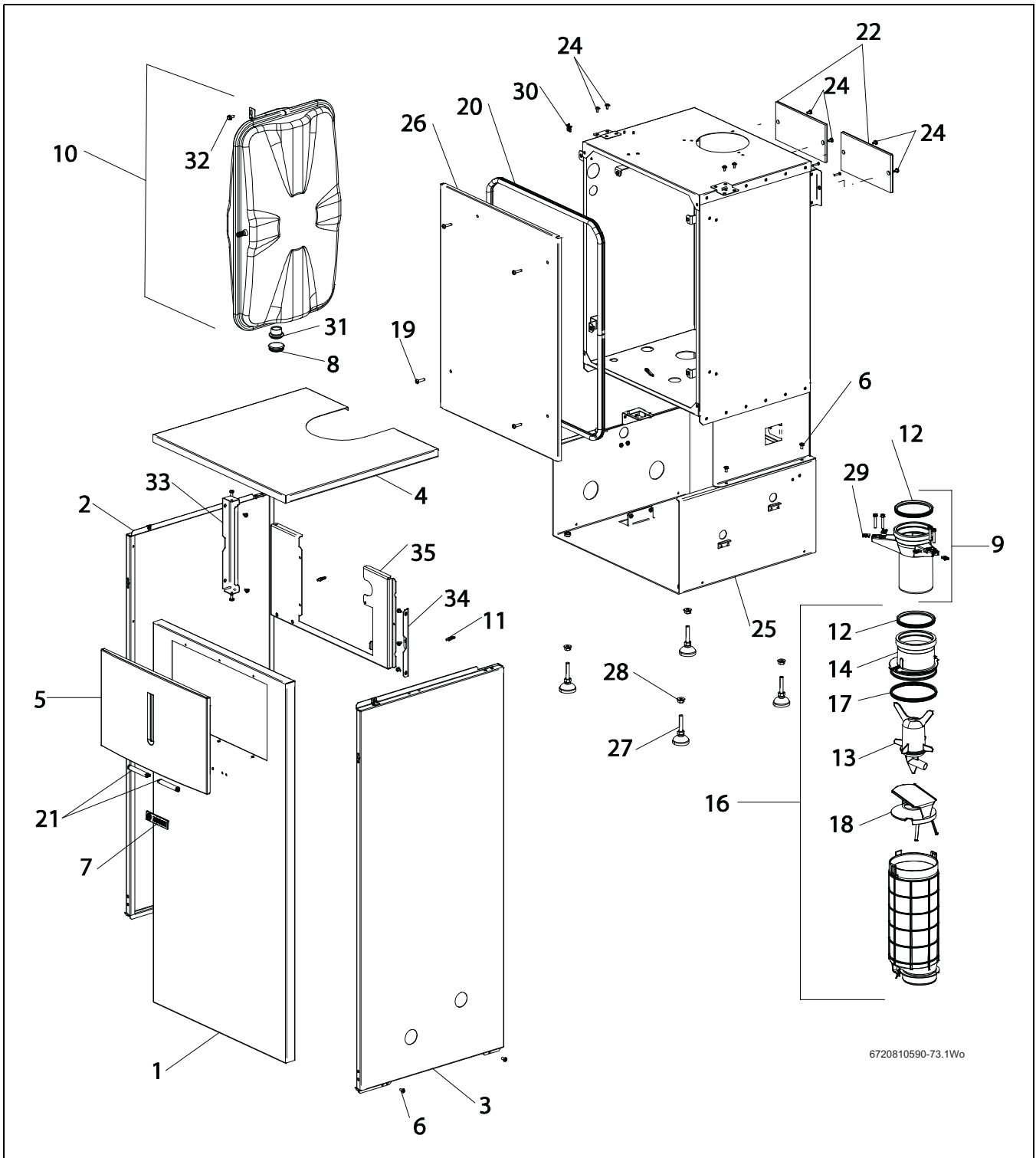

6720810590-73.1Wo

Fig. 98 Group 1 - Sheet metal Greenstar

Item (→ Fig. 98)	Designation	KBR16-3	KBR21-3	KBR28-3	KBR35-3	KBR42-3	KWB28-3	KWB35-3	KWB42-3	Order number
1	Case front panel assembly	■	■	■	■	■	■	■	■	8 716 117 483
2	Case side panel LH assembly	■	■	■	■	■	■	■	■	8 716 117 484
3	Case side panel RH assembly						■	■	■	8 716 117 485
3	Case side panel RH assembly	■	■	■	■	■				8 716 117 249
4	Case top panel assembly	■	■	■	■	■	■	■	■	8 716 117 486
5	Cover	■	■	■	■	■	■	■	■	8 718 681 234 0
6	Screw (10x) M5 x 12	■	■	■	■	■	■	■	■	2 914 411 420 0
7	Trade mark badge Bosch	■	■	■	■	■	■	■	■	8 716 011 807 0
8	Washer	■	■	■	■	■				8 710 302 042 0
9	Terminal exhaust adaptor WB5	■	■	■	■	■	■	■	■	8 716 117 335
10	Expansion vessel						■	■	■	8 715 407 328 0
11	Shape screw	■	■	■	■	■	■	■	■	8 713 407 021 0
12	Washer 80mm	■	■	■	■	■	■	■	■	8 711 004 232 0
13	Resonator				■	■		■	■	8 716 117 337
14	Adaptor	■	■	■	■	■	■	■	■	8 716 117 334
16	Silencer	■	■	■	■	■	■	■	■	8 710 725 353 0
17	Seal	■	■	■	■	■	■	■	■	8 711 004 278 0
18	Throttle disc		■	■	■	■	■	■	■	8 7 10 100 209 0
19	Screw M5 x 20mm	■	■	■	■	■	■	■	■	8 716 117 397
20	Seal	■	■	■	■	■	■	■	■	8 716 117 487
21	Damper (2x)	■	■	■	■	■	■	■	■	8 713 204 016 0
22	Assembly junction box cover	■	■	■	■	■	■	■	■	8 716 117 488
24	Screw (10x)	■	■	■	■	■	■	■	■	2 910 611 424 0
26	Case inner door	■	■	■	■	■	■	■	■	8 716 117 490
27	Foot M8	■	■	■	■	■	■	■	■	8 716 117 299
28	Nut M8 with flange	■	■	■	■	■	■	■	■	8 718 682 332 0
29	Nut (10x)	■	■	■	■	■	■	■	■	8 710 609 015 0
30	Clip capillary guide	■	■	■	■	■	■	■	■	8 716 117 033
31	Washer						■	■	■	8 710 103 209 0
32	Screw metrical thread spec M5 x 12mm x 10						■	■	■	8 716 117 491
33	Hinge bracket LH	■	■	■	■	■	■	■	■	8 716 117 492
34	Bracket RH	■	■	■	■	■	■	■	■	8 716 117 493
35	Bracket control box assembly	■	■	■	■	■	■	■	■	8 716 117 494

Table 37 Group 1 - Sheet metal Greenstar

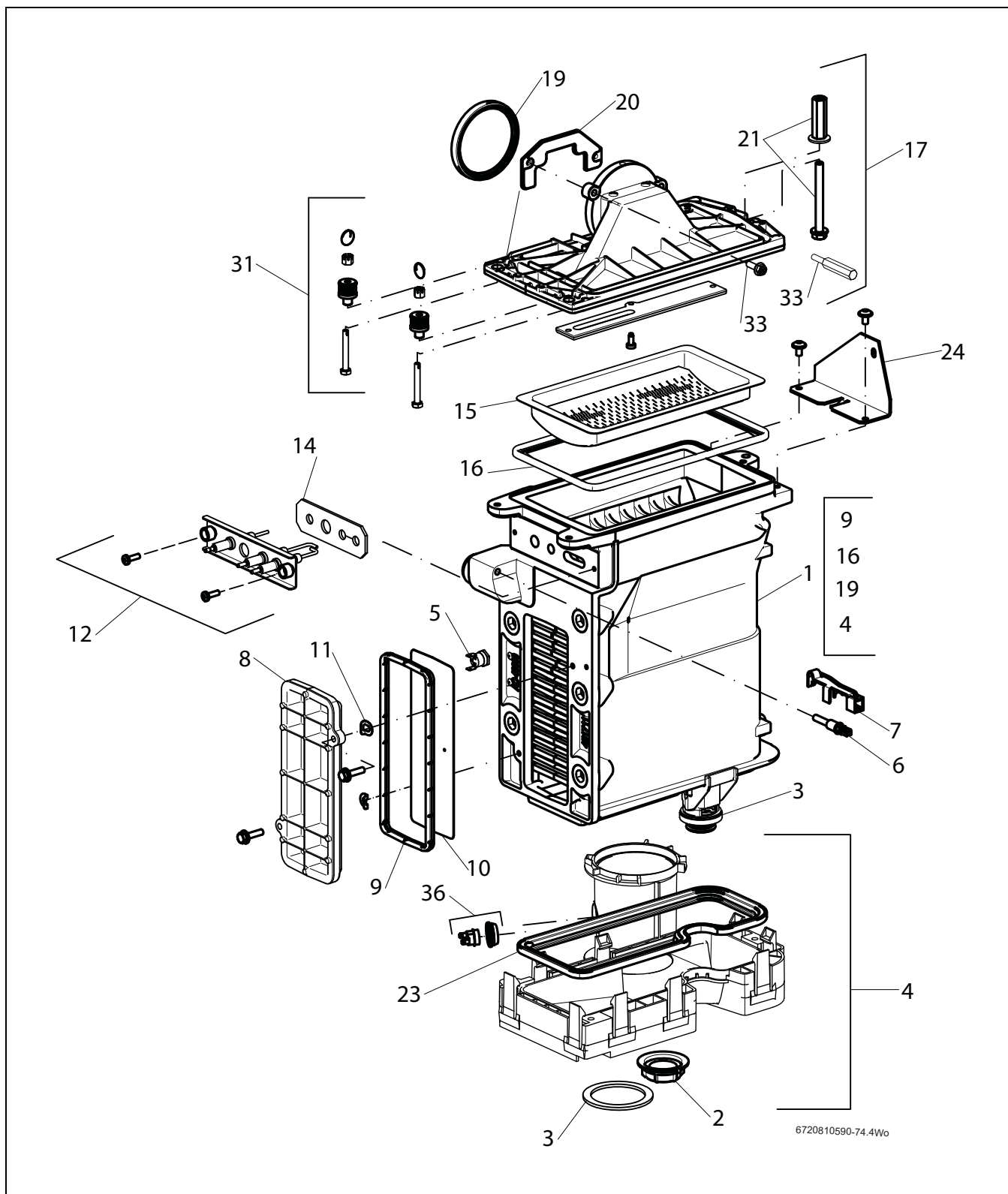
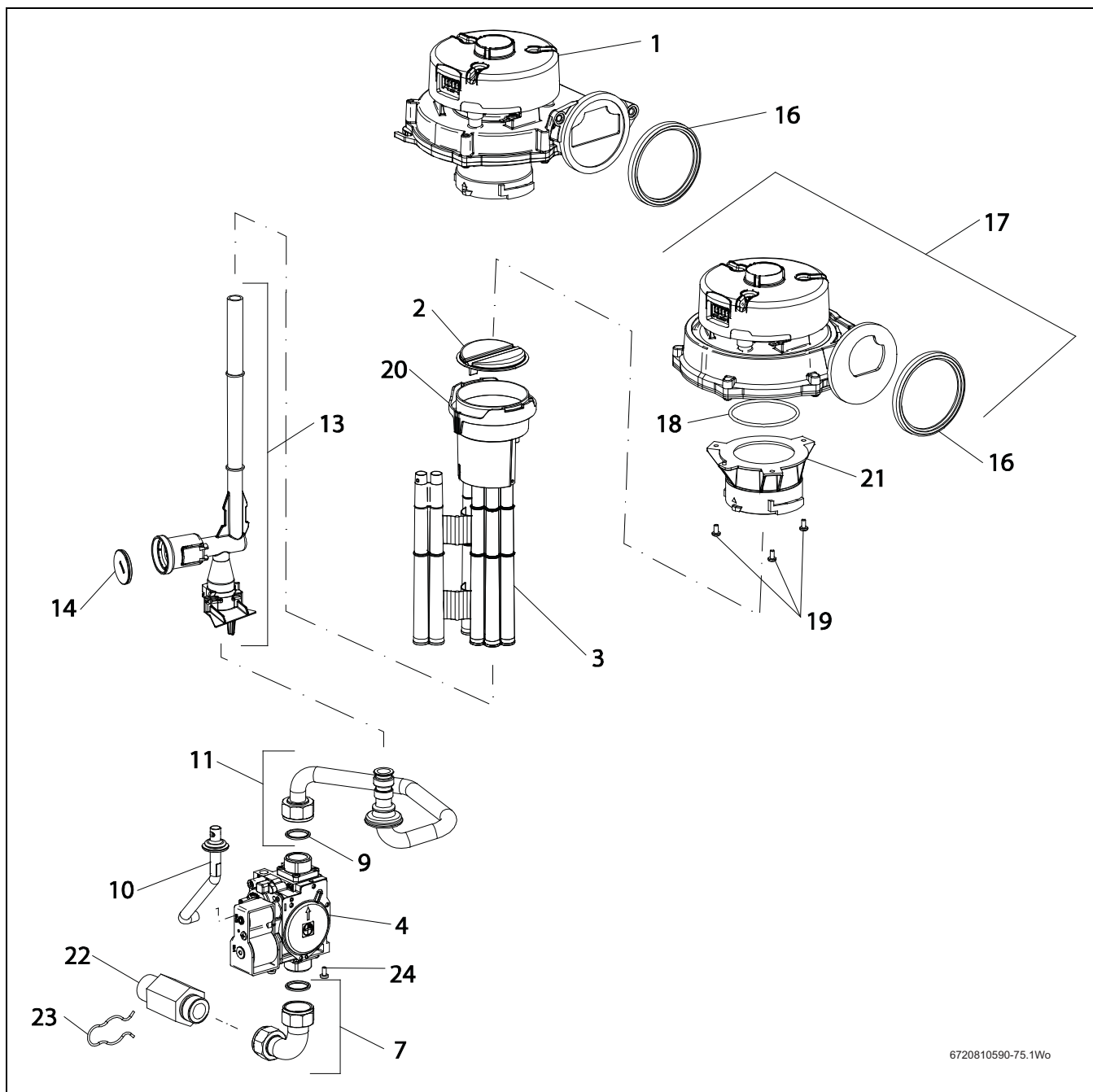

Fig. 99 Group 2 - Burner/Heat exchanger Greenstar

Item (→ Fig. 99)	Designation	KBR16-3A	KBR21-3A	KBR28-3A	KBR35-3A	KBR42-3A	KWB28-3A	KWB35-3A	KWB42-3A	Order number
1	Heat exchanger block						■	■	■	8 716 117 497
1	Heat exchanger block (incl. set of gaskets)	■	■	■	■	■				8 737 701 797 0
2	Nut	■	■	■	■	■	■	■	■	8 713 301 196 0
3	Set of washers	■	■	■	■	■	■	■	■	8 710 103 206 0
4	Flue gas collector	■	■	■	■	■	■	■	■	8 718 006 944 0
5	Temperature limit sensor	■	■	■	■	■	■	■	■	8 722 963 858 0
6	Sensor NTC - Control stat	■	■	■	■	■	■	■	■	8 716 117 332
7	Bracket NTC WB5	■	■	■	■	■	■	■	■	8 716 117 331
8	Cover	■	■	■	■	■	■	■	■	8 711 000 262 0
9	Sealing	■	■	■	■	■	■	■	■	8 710 103 153 0
10	Shield	■	■	■	■	■	■	■	■	8 718 003 836 0
11	Clip (10x)	■	■	■	■	■	■	■	■	8 710 100 190 0
12	Set of electrodes	■	■	■	■	■	■	■	■	8 718 664 3010
14	Seal	■	■	■	■	■	■	■	■	8 718 664 402
15	Burner	■	■	■	■	■	■	■	■	8 718 006 658 0
16	Burner sealing	■	■	■	■	■	■	■	■	8 711 004 168 0
17	Cover				■	■		■	■	8 715 406 318 0
17	Cover	■	■	■			■			8 715 416 029 0
18	Fixing set	■	■	■	■	■	■	■	■	8 710 305 296 0
19	Seal	■	■	■	■	■	■	■	■	8 711 004 146 0
20	Bracket fan				■	■	■	■	■	8 716 117 333
21	Fixing bolt	■	■	■	■	■	■	■	■	8 710 305 297 0
23	Washer	■	■	■	■	■	■	■	■	8 710 103 155 0
24	Bracket heat cell fixing	■	■	■	■	■	■	■	■	8 716 117 328
31	Fixing set	■	■	■	■	■	■	■	■	8 710 305 296 0
33	Screw set	■	■	■	■	■	■	■	■	8 716 117 339
36	Temperature limiter assembly	■	■	■	■	■	■	■	■	8 710 506 267 0

Table 38 Group 2 - Burner/Heat exchanger Greenstar



6720810590-75.1Wo

Fig. 100 Group 3 - Gas valve Greenstar

Item (→ Fig. 100)	Designation	KBR16-3	KBR21-3	KBR28-3	KBR35-3	KBR42-3	KWB28-3	KWB35-3	KWB42-3	Order number
1	Fan RG130 USA	■	■	■			■			8 718 226 185 0
2	Diaphragm valve	■	■	■	■	■	■	■	■	8 715 505 928 0
3	Pipe		■	■	■	■	■	■	■	8 716 117 336
4	Gas valve USA	■	■	■	■	■	■	■	■	8 718 226 391 0
7	Gas pipe	■	■	■	■	■	■	■	■	8 716 117 501
9	Washer set-mounting set	■	■	■	■	■	■	■	■	8 716 115 535 0
10	Pressure balance tube	■	■	■	■	■	■	■	■	8 718 221 063 0
11	Gas pipe top USA	■	■	■	■	■	■	■	■	8 718 225 762 0
13	Gas pipe	■	■	■	■	■	■	■	■	8 710 735 387 0
14	Lead seal	■	■	■	■	■	■	■	■	8 716 117 348
16	Washer	■	■	■	■	■	■	■	■	8 729 000 183 0
17	Fan RG128 USA				■	■		■	■	8 718 226 184 0
18	O-ring (10x)				■	■		■	■	8 722 880 175 0
19	Screw M4 x 8mm taptite zc pl p/h				■	■		■	■	2 914 411 412 0
20	Air limiter				■	■		■	■	8 710 505 210 0
20	Air limiter		■	■			■			8 710 505 212 0
20	Air limiter	■								8 716 117 452
21	Connecting flange				■	■		■	■	8 710 506 279 0
22	Nipple USA gas ¾ inch	■	■	■	■	■	■	■	■	8 716 117 502
23	Wireform spring (10x)	■	■	■	■	■	■	■	■	8 714 606 002 0
24	Screw M4 x 6 Taptite ZC PL P/H	■	■	■	■	■	■	■	■	2 914 411 424 0

Table 39 Group 3 - Gas valve Greenstar

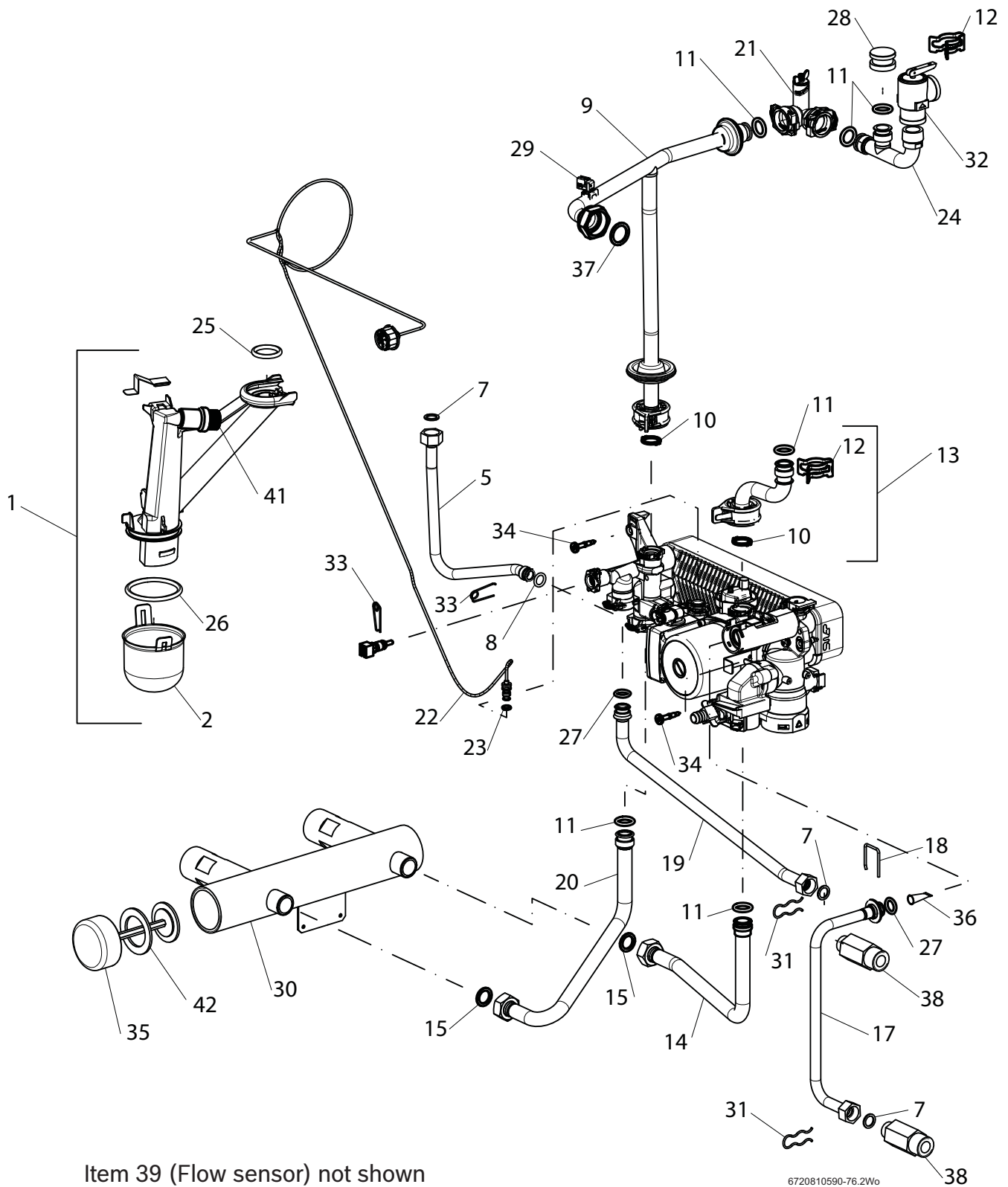

Fig. 101 Group 4 - Pipes combi boiler KWB..3A Greenstar

Item (→ Fig. 101)	Designation	KBR16-3	KBR21-3	KBR28-3	KBR35-3	KBR42-3	KWB28-3	KWB35-3	KWB42-3	Order number
1	Siphon						■	■	■	8 710 506 271 0
2	Siphon cap						■	■	■	8 710 506 273 0
5	Pipe expansion vessel						■	■	■	8 716 117 514
7	Washer 16.6 x 13.5 x 1.5 (10x)						■	■	■	8 710 103 045 0
8	O-ring 12.5 x 3 WRAS/KTW (1x)						■	■	■	8 716 106 748 0
9	Pipe flow						■	■	■	8 716 117 515
10	Washer 18.5 x 24.3 (10x)						■	■	■	8 716 771 259 0
11	O-ring						■	■	■	8 710 205 085 0
12	Clip (10x) 18						■	■	■	8 711 200 024 0
13	Return pipe						■	■	■	8 710 735 324 0
14	Return pipe CH						■	■	■	8 716 117 516
15	Washer 23.9 x 17.2 x 1.5 (1x)						■	■	■	8 716 115 674 0
17	Pipe DHW inlet						■	■	■	8 716 117 517
18	Safety clip supply sensor						■	■	■	8 716 106 488 0
19	Pipe DHW flow						■	■	■	8 716 117 518
20	Pipe CH flow						■	■	■	8 716 117 519
21	Elbow flow pipe						■	■	■	8 716 106 499 0
22	Pressure gauge USA						■	■	■	8 716 117 503
23	O-ring 2.62 x 6.02 ID EPDM (10x)						■	■	■	8 716 140 810 0
24	Upper rear pipe						■	■	■	8 716 117 511
25	O-ring 26.34 x 5.33 (5x)						■	■	■	8 710 205 098 0
26	Washer set						■	■	■	8 710 103 154 0
27	O-ring 13.87 x 3.5. L (10x)						■	■	■	8 716 107 439 0
28	Cap closing connection						■	■	■	8 716 117 508
29	Temperature sensor						■	■	■	8 714 500 117 0
30	Assembly LLH						■	■	■	8 716 117 509
31	Wireform spring (10x)						■	■	■	8 714 606 004 0
32	Safety valve USA 30psi						■	■	■	8 718 117 919 0
33	Retaining spring (10x)						■	■	■	8 718 771 167 0
34	Screw M5 x 32						■	■	■	8 716 771 687 0
35	Assembly LLH plunger						■	■	■	8 716 117 512
36	DHW filter insert						■	■	■	8 716 106 486 0
37	Washer 1 inch (10x)						■	■	■	8 710 103 046 0
38	Nipple MAPL USA G ½ - ¾ inch NPT						■	■	■	8 716 117 522
39	Flow sensor assembly						■	■	■	8 716 117 513
41	Hose						■	■	■	8 718 220 106 0
42	Washer 60 x 41 x 3						■	■	■	8 716 117 918

Table 40 Group 4 - Pipes combi boiler KWB..3A Greenstar

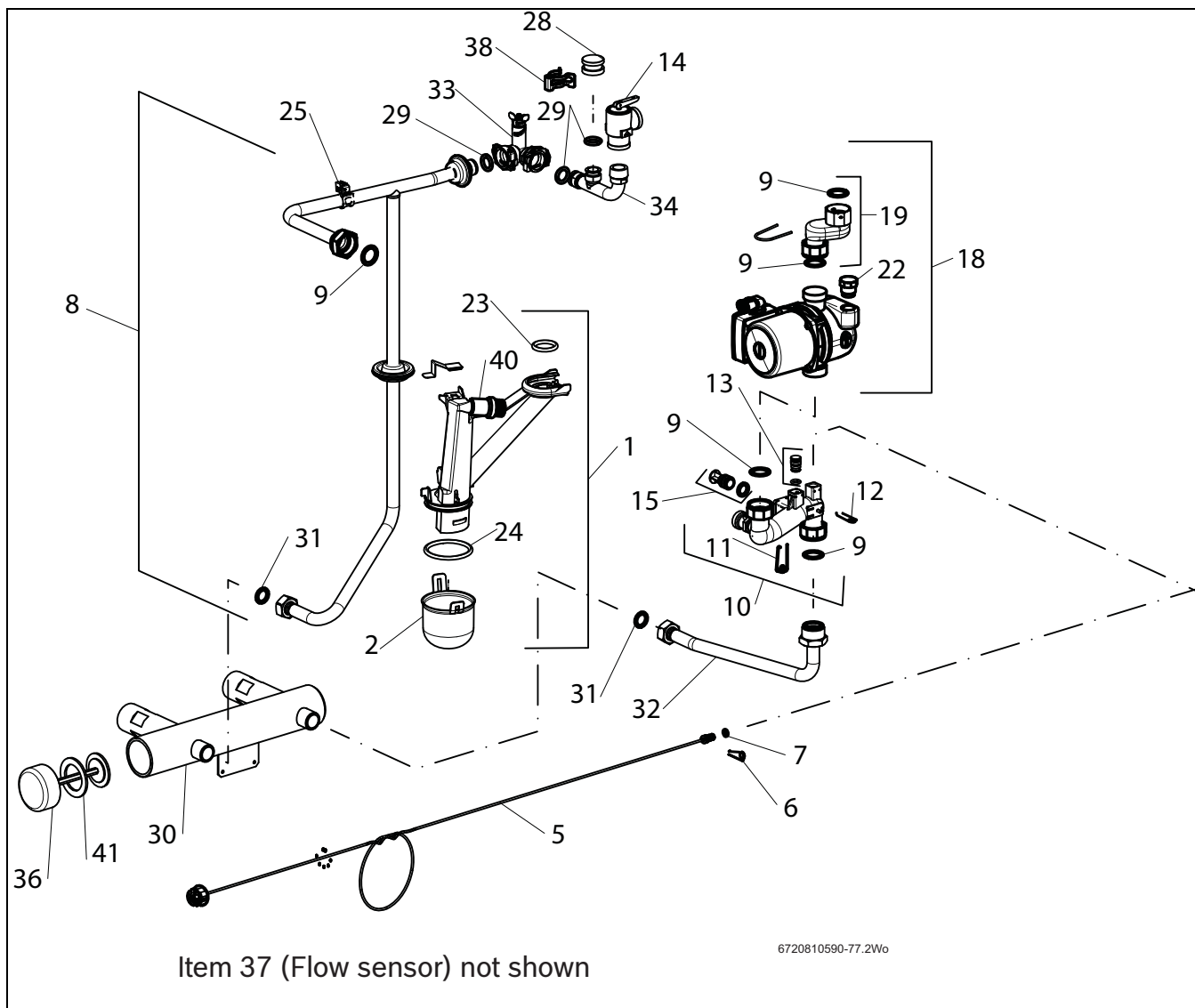
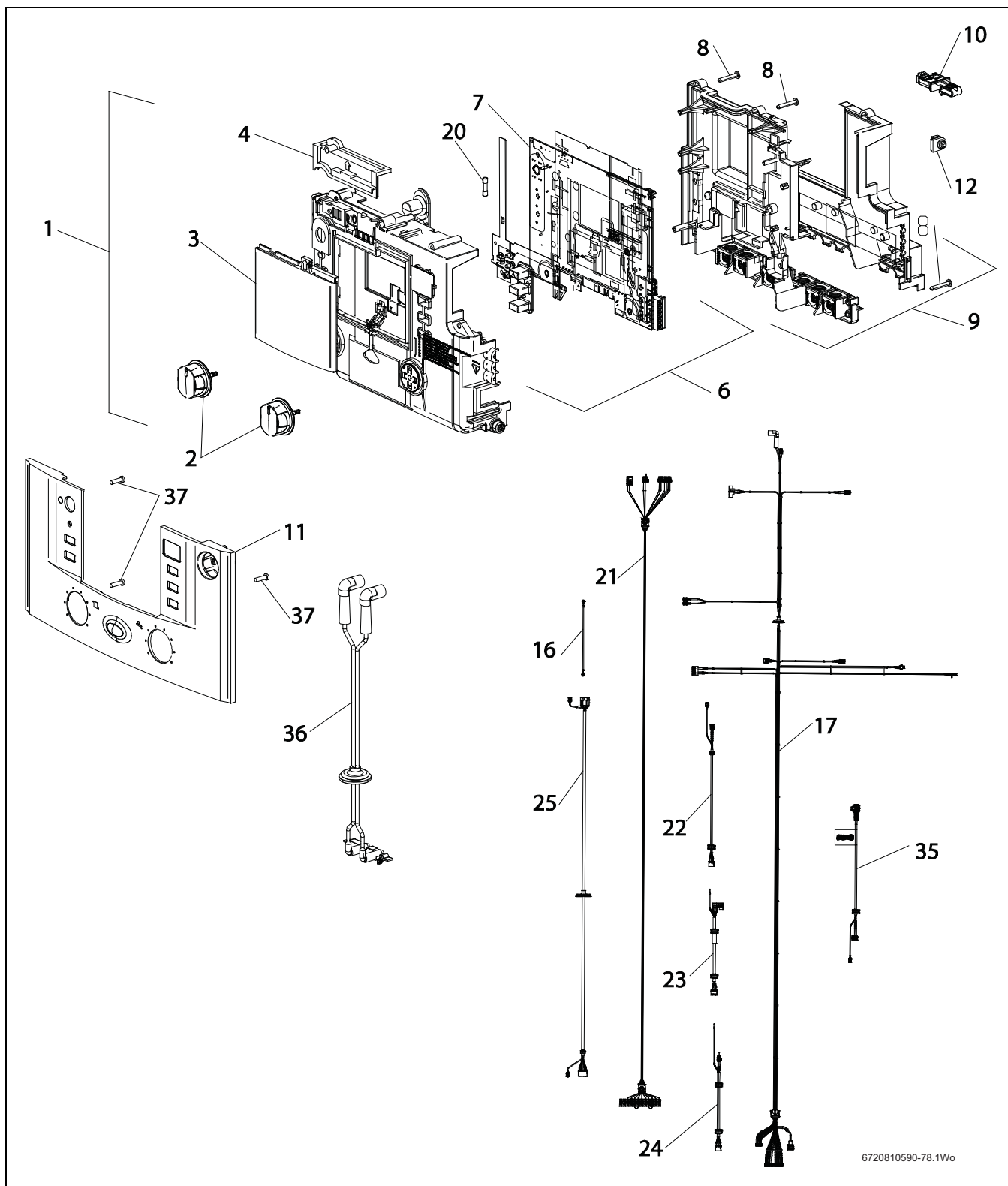

Fig. 102 Group 5 Pipes heating boiler KBR.. 3A Greenstar

Item (→ Fig. 102)	Designation	KBR16-3	KBR21-3	KBR28-3	KBR35-3	KBR42-3	KWB28-3	KWB35-3	KWB42-3	Order number
1	Siphon	■	■	■	■	■				8 710 506 271 0
2	Cover	■	■	■	■	■				8 710 506 273 0
5	Pressure gauge USA	■	■	■	■	■				8 716 117 503
6	Retaining spring 10mm (10x)	■	■	■	■	■				8 716 771 167 0
7	O-ring 2.62 x 6.02 ID EPDM (10x)	■	■	■	■	■				8 716 140 810 0
8	Flow pipe	■	■	■	■	■				8 716 117 504
9	Washer 1 inch (10x)	■	■	■	■	■				8 710 103 046 0
10	Return	■	■	■	■	■				8 716 117 505
11	Clip wire 18mm (10x)	■	■	■	■	■				8 718 684 699 0
12	Clip wire 10mm (10x)	■	■	■	■	■				8 716 771 167 0
13	Plug	■	■	■	■	■				8 718 117 919 0
14	Safety valve USA 30psi	■	■	■	■	■				8 718 226 180 0
15	Expansion vessel plug	■	■	■	■	■				8 716 117 898
18	Pump KBR USA	■	■	■	■	■				8 718 226 172 0
19	Return pipe	■	■	■	■	■				8 710 735 450 0
22	Plug	■	■	■	■	■				8 713 301 152 0
23	O-ring 26.34 x 5.33 (5x)	■	■	■	■	■				8 710 205 098 0
24	Washer set	■	■	■	■	■				8 710 103 154 0
25	Temperature sensor	■	■	■	■	■				8 714 500 117 0
28	Cap closing connection	■	■	■	■	■				8 716 117 508
29	O-ring 17 x 4 (5x)	■	■	■	■	■				8 710 205 085 0
30	Assembly LLH	■	■	■	■	■				8 716 117 509
31	Washer 23.9 x 17.2 x 1.5 (1x)	■	■	■	■	■				8 716 115 674 0
32	Pipe CH return regular	■	■	■	■	■				8 716 117 510
33	Elbow flow pipe	■	■	■	■	■				8 716 106 499 0
34	Upper rear pipe	■	■	■	■	■				8 716 117 511
36	Assembly LLH plunger	■	■	■	■	■				8 716 117 512
37	Flow sensor assembly	■	■	■	■	■				8 716 117 513
38	Clip (10x) 18	■	■	■	■	■				8 711 200 024 0
40	Hose	■	■	■	■	■				8 718 220 106 0
41	Washer 60 x 41 x 3	■	■	■	■	■				8 716 117 918

Table 41 Group 5 Pipes heating boiler KBR.. 3A Greenstar



6720810590-78.1Wo

Fig. 103 Group 6 - Control box Greenstar

Item(→ Fig. 103)	Designation	KBR16-3A	KBR21-3A	KBR28-3A	KBR35-3A	KBR42-3A	KWB28-3A	KWB35-3A	KWB42-3A	Order number
1	Control unit HTS Bosch USA	■	■	■	■	■	■	■	■	8 737 704 671 0
2	Rotary selector	■	■	■	■	■	■	■	■	8 716 011 785 0
3	Cover	■	■	■	■	■	■	■	■	8 711 000 302 0
4	Cover	■	■	■	■	■	■	■	■	8 717 207 680 0
6	Set of connectors	■	■	■	■	■	■	■	■	8 714 404 348 0
7	Printed Circuit Board	■	■	■	■	■	■	■	■	8 748 300 739 0
8	Screw	■	■	■	■	■	■	■	■	8 713 403 029 0
9	Backpanel	■	■	■	■	■	■	■	■	8 613 560 409 0
10	Code plug 2500 NG (23)								■	8 714 432 500 0
	Code plug 2501 NG (23)	■								8 714 432 501 0
	Code plug 2502 NG (23)			■						8 714 432 502 0
	Code plug 2503 NG (23)				■					8 714 432 503 0
	Code plug 2504 NG (23)					■				8 714 432 504 0
	Code plug 2505 LPG (31)								■	8 714 432 505 0
	Code plug 2506 LPG (31)	■								8 714 432 506 0
	Code plug 2507 LPG (31)			■						8 714 432 507 0
	Code plug 2508 LPG (31)				■					8 714 432 508 0
	Code plug 2509 LPG (31)					■				8 714 432 509 0
	Code plug 2520 NG (23)						■			8 714 432 520 0
	Code plug 2521 LPG (31)						■			8 714 432 521 0
	Code plug 2524 NG (23)							■		8 714 432 524 0
	Code plug 2525 LPG (31)							■		8 714 432 525 0
	Code plug 2528 NG (23)		■							8 714 432 528 0
	Code plug 2529 LPG (31)		■							8 714 432 529 0
11	Cover	■	■	■	■	■	■	■	■	8 737 702 329 0
12	Grommet (10x)						■	■	■	8 710 506 185 0
16	Earth harness	■	■	■	■	■	■	■	■	8 716 117 523
17	Harness low voltage appliance	■	■	■	■	■	■	■	■	8 716 117 524
20	Fuse	■	■	■	■	■	■	■	■	8 744 503 045 0
21	Harness accessories	■	■	■	■	■	■	■	■	8 716 117 525
22	Cable storage tank pump	■	■	■	■	■				8 716 117 526
23	Cable mains 120V	■	■	■	■	■	■	■	■	8 716 117 527
24	Cable CH pump	■	■	■	■	■	■	■	■	8 716 117 528
25	Cable power cord fan assembly	■	■	■	■	■	■	■	■	8 716 117 529
35	Cable pump harness USA	■	■	■	■	■	■	■	■	8 716 117 530
36	Ignition harness	■	■	■	■	■	■	■	■	8 716 106 799 0
37	M4 x 14 PT POZI PAN Z/P screw	■	■	■	■	■	■	■	■	2 914 201 304 0
-	LPG conversion kit 42kw					■				8 716 117 521
-	LPG conversion kit 35kw				■					8 716 117 534
-	LPG conversion kit 28kw			■						8 716 117 535
-	LPG conversion kit 21kw		■							8 716 117 536
-	LPG conversion kit 16kw	■								8 716 117 538
-	LPG conversion kit 42kw								■	8 716 117 539
-	LPG conversion kit 35kw							■		8 716 117 540
-	LPG conversion kit 28kw						■			8 716 117 541

Table 42 Group 6 - Control box Greenstar

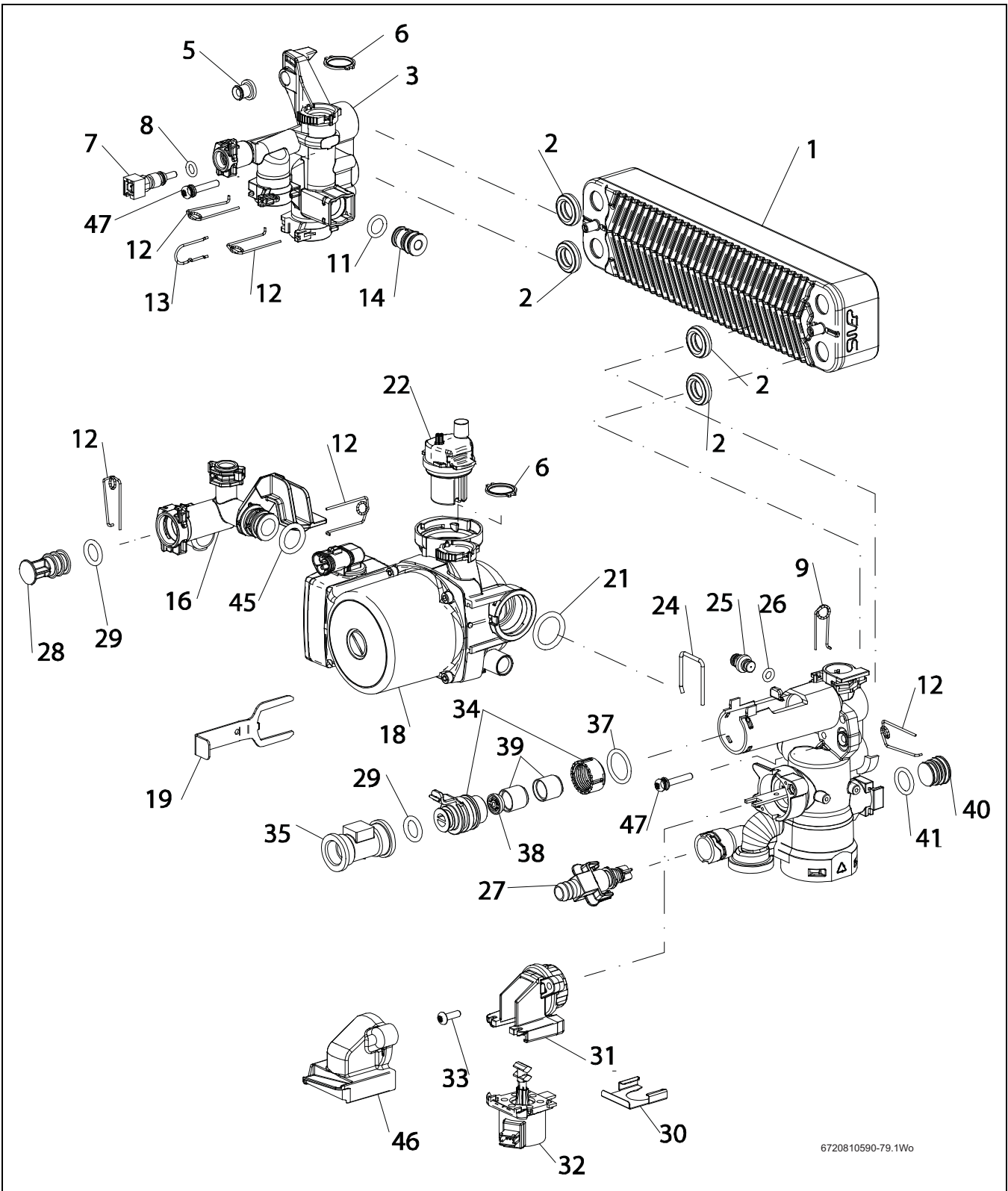

Fig. 104 Group 7 Hydraulic block combi boiler KWB.. 3A Greenstar

Item (→ Fig. 104)	Designation	KBR16-3	KBR21-3	KBR28-3	KBR35-3	KBR42-3	KWB28-3	KWB35-3	KWB42-3	Order number
1	Flat plate heat exchanger 18 plates						■	■	■	8 716 108 212 0
2	Seal 15mm						■	■	■	8 716 106 435 0
3	Supply manifold complete						■	■	■	8 716 106 356 0
5	Rubber bushing						■	■	■	8 716 106 425 0
6	Washer 18.5 x 24.3 (10x)						■	■	■	8 716 771 259 0
7	Sensor NTC						■	■	■	8 716 117 532
8	O-ring 7.75 x 2.1 (10x)						■	■	■	8 710 205 080 0
9	Wire clip 10mm						■	■	■	8 716 117 533
11	O-ring 12.5 x 3 WRAS/KTW (1x)						■	■	■	8 716 106 748 0
12	Wire clip 18mm (10x)						■	■	■	8 718 684 699 0
13	Safety clip 13mm (1x)						■	■	■	8 716 106 549 0
14	Plug						■	■	■	8 716 106 566 0
16	Tee						■	■	■	8 716 117 396
18	Pump USA						■	■	■	8 718 226 173 0
19	Safety pump clip						■	■	■	8 716 106 438 0
21	O-ring 23 x 4 (10x)						■	■	■	8 716 771 353 0
22	Air vent valve						■	■	■	8 716 106 445 0
24	Safety clip supply sensor						■	■	■	8 716 106 488 0
25	Pressure relief valve DHW						■	■	■	8 717 401 029 0
26	O-ring 6.00 x 2.50 WRAS/KTW (1x)						■	■	■	8 716 116 074 0
27	Drain valve						■	■	■	8 716 771 432 0
28	Expansion vessel plug						■	■	■	8 716 117 507
29	O-ring 13.87 x 3.53 L (10x)						■	■	■	8 716 107 439 0
30	Safety clip inlet adapter						■	■	■	8 716 106 432 0
31	Diverter valve assembly						■	■	■	8 716 106 845 0
32	Diverter valve assembly motor						■	■	■	8 716 106 847 0
33	Screw M5 stainless						■	■	■	8 716 106 848 0
34	Flow turbine adapter						■	■	■	8 716 106 433 0
35	Flow sensor						■	■	■	8 737 600 781 0
37	O-ring 22 x 3 L						■	■	■	8 716 117 069
38	Flow regulator 15/LM 4GPM								■	8 716 105 869 0
	Flow limiter insert 10lt						■			8 716 141 057 0
	Flow regulator type E-W 12l/min red							■		8 716 141 061 0
39	Silencer						■	■	■	8 737 600 963 0
40	Plug						■	■	■	8 716 106 567 0
41	O-ring 16 x 3 EPDM (10x)						■	■	■	8 716 107 436 0
45	O-ring						■	■	■	8 710 205 085 0
46	Diverter valve housing						■	■	■	8 716 112 786 0
47	Screw & washer assembly M5 x 30						■	■	■	8 716 106 452 0

Table 43 Group 7 Hydraulic block combi boiler KWB.. 3A Greenstar

Item	Designation	KBR16-3	KBR21-3	KBR28-3	KBR35-3	KBR42-3	KWB28-3	KWB35-3	KWB42-3	Order number
-	Brush set WB5	■	■	■	■	■	■	■	■	7 719 002 502
-	Cleaning blade WB5	■	■	■	■	■	■	■	■	7 719 002 503
-	Packaging	■	■	■	■	■	■	■	■	7 716 117 537
-	Adapter minimum pressure switch	■	■	■	■	■	■	■	■	8 718 226 386 0

Table 44 Group 8 - Accessories for service/installation Greenstar



United States and Canada

Bosch Thermotechnology Corp.
50 Wentworth Avenue
Londonderry, NH03053
Tel. 603-552-1100
Fax 603-965-7581
www.bosch-climate.us
U.S.A.

Products manufactured by:
Worcester, Bosch Group,
Cotswold Way,
Worcester WR4 9SW
www.worcester-bosch.co.uk

Bosch Thermotechnology Corp. reserves the right
to make changes without notice due to continuing
engineering and technological advances