



325 COMMERCE DRIVE
 MT VERNON, OH 43050
 800-253-8236

SPECIFICATION DATA SHEET

DATE: 7-29-11
 PREPARED BY: RL

MODEL NO. 136

Plenum Takeoff

STANDARD MODEL

DIMENSIONS

SIZE	A	B	C	D	E
6 1/2x6 1/2x4	6 1/2"	6 1/2"	4"	2"	4"
6 1/2x6 1/2x5	6 1/2"	6 1/2"	5"	2 1/16"	4 1/4"
6 1/2x6 1/2x6	6 1/2"	6 1/2"	6"	2 1/16"	4 1/4"
6 1/2x10x6	6 1/2"	10"	6"	2 1/16"	4 1/4"
6 1/2x10x7	6 1/2"	10"	7"	2"	4 3/4"
6 1/2x12x7	6 1/2"	12"	7"	2"	4 3/4"
6 1/2x12x8	6 1/2"	12"	8"	1 1/16"	5 1/4"
6 1/2x14x8	6 1/2"	14"	8"	1 1/16"	5 1/4"
7x13x9	7"	13"	9"	1 3/16"	4 3/4"
7x14x10	7"	14"	10"	1 9/16"	5"
7x16x12	7"	16"	12"	1 9/16"	5"
7x18x14	7"	18"	14"	1 9/16"	4 7/8"

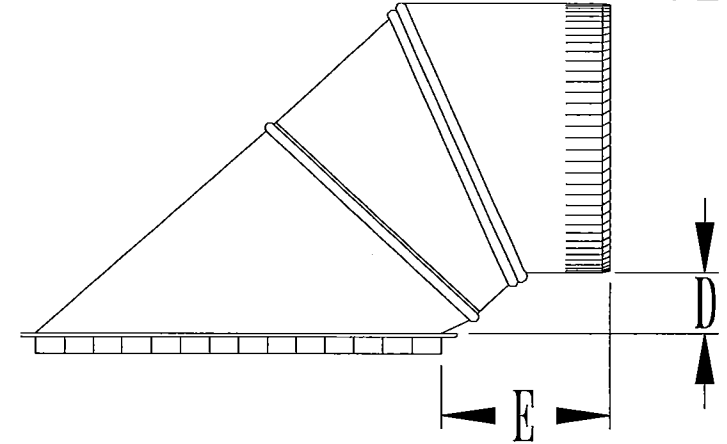

MATERIAL SPECIFICATIONS

HOT DIPPED GALVANIZED STEEL.
 PER ASTM A 653 CSB.

4"-8" STD GA
 9"-14" 28GA

ASSEMBLED WITH 1/8" ZINC COATED RIVETS.

FOR MORE SPECS ON THE TAKEOFF ANGLE
 VIEW THE "HCP_151" FILE.

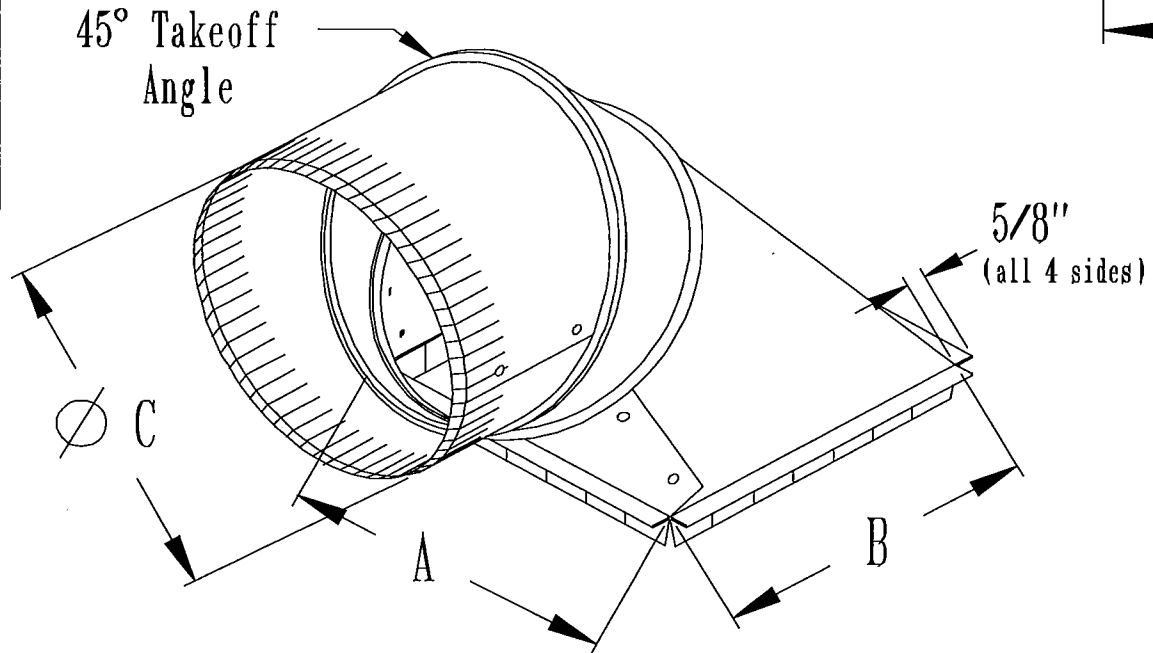

OPTIONS

JOB: _____
 LOCATION: _____
 CONTRACTOR: _____
 ENGINEER: _____
 NOTES: _____