



325 COMMERCE DRIVE  
 MT VERNON, OH 43050  
 800-253-8236

**SPECIFICATION DATA SHEET**

DATE: 7-17-13 PAGE: 1  
 PREPARED BY: RL

**MODEL NO. 529**

**WYE**

STANDARD MODEL

**DIMENSIONS**

SIZE			D	E	F	G	H	I	J	K
A	x B	x C								
3"	x 3"	x 3"	2 1/4"	2 1/4"	2 1/4"	10 3/4"	6 3/4"	8 15/16"	7 1/4"	9 3/8"
4"	x 3"	x 3"	2 1/4"	2 1/4"	2 1/4"	11 1/2"	7 7/16"	9 1/2"	7 7/8"	9 15/16"
4"	x 4"	x 3"	2 1/4"	2 1/4"	2 1/4"	12 1/8"	8 3/16"	10 5/16"	8 3/16"	10 7/16"
4"	x 4"	x 4"	2 1/4"	2 1/4"	2 1/4"	12"	7 3/4"	10 9/16"	7 5/8"	10 7/16"
5"	x 3"	x 3"	2 1/4"	2 1/4"	2 1/4"	11 3/8"	7 3/16"	7 5/16"	7 1/2"	9 5/8"
5"	x 4"	x 3"	2 1/4"	2 1/4"	2 1/4"	11 1/8"	8 3/16"	10 5/16"	7 1/4"	9 3/8"
5"	x 4"	x 4"	2 1/4"	2 1/4"	2 1/4"	10 15/16"	7 11/16"	10 1/2"	6 1/2"	9 5/16"
5"	x 5"	x 3"	2 1/4"	2"-HEM	2 1/4"	12 3/16"	9 3/16"	11 5/16"	8 5/16"	10 1/2"
5"	x 5"	x 4"	2 1/4"	2"-HEM	2 1/4"	13 1/4"	9 3/16"	12"	8 15/16"	11 3/4"
5"	x 5"	x 5"	2 1/4"	2"-HEM	2"-HEM	11 3/4"	7 3/4"	11 5/16"	7 1/4"	10 3/4"
6"	x 3"	x 3"	2 1/4"	2 1/4"	2 1/4"	11 3/8"	7 7/16"	9 9/16"	7 7/16"	9 1/2"
6"	x 4"	x 3"	2 1/4"	2 1/4"	2 1/4"	10 1/4"	8 3/16"	10 5/16"	6 3/8"	8 1/2"
6"	x 4"	x 4"	2 1/4"	2 1/4"	2 1/4"	11 5/8"	8 3/16"	11"	7 1/16"	9 15/16"
6"	x 5"	x 3"	2 1/4"	2 1/4"	2 1/4"	10 15/16"	9 3/16"	11 5/16"	7 5/16"	9 7/16"
6"	x 5"	x 4"	2 1/4"	2 1/4"	2 1/4"	12 5/16"	9 3/16"	12"	8"	10 7/8"
6"	x 5"	x 5"	2 1/4"	2 1/4"	2"-HEM	11 1/4"	8 1/4"	11 3/4"	6 5/8"	10 1/8"
6"	x 6"	x 3"	2 1/4"	2"-HEM	2 1/4"	12 9/16"	10 5/8"	12 3/4"	8 3/4"	10 7/8"
6"	x 6"	x 4"	2 1/4"	2"-HEM	2 1/4"	13 3/8"	10 3/16"	13"	9 1/16"	11 7/8"
6"	x 6"	x 5"	2 1/4"	2"-HEM	2"-HEM	11 3/4"	9 1/4"	12 13/16"	7 1/8"	10 5/8"
6"	x 6"	x 6"	2 1/4"	2"-HEM	2"-HEM	12 3/8"	8 11/16"	12 15/16"	7 1/4"	11 1/2"
7"	x 5"	x 3"	2 1/4"	2"-HEM	2 1/4"	9 1/2"	8 15/16"	11 1/16"	6 1/16"	8 1/8"
7"	x 5"	x 4"	2 1/4"	2"-HEM	2 1/4"	10 15/16"	8 15/16"	11 3/4"	6 13/16"	9 5/8"
7"	x 5"	x 5"	2 1/4"	2"-HEM	2"-HEM	12 3/4"	9 3/16"	12 3/4"	7 13/16"	11 5/16"

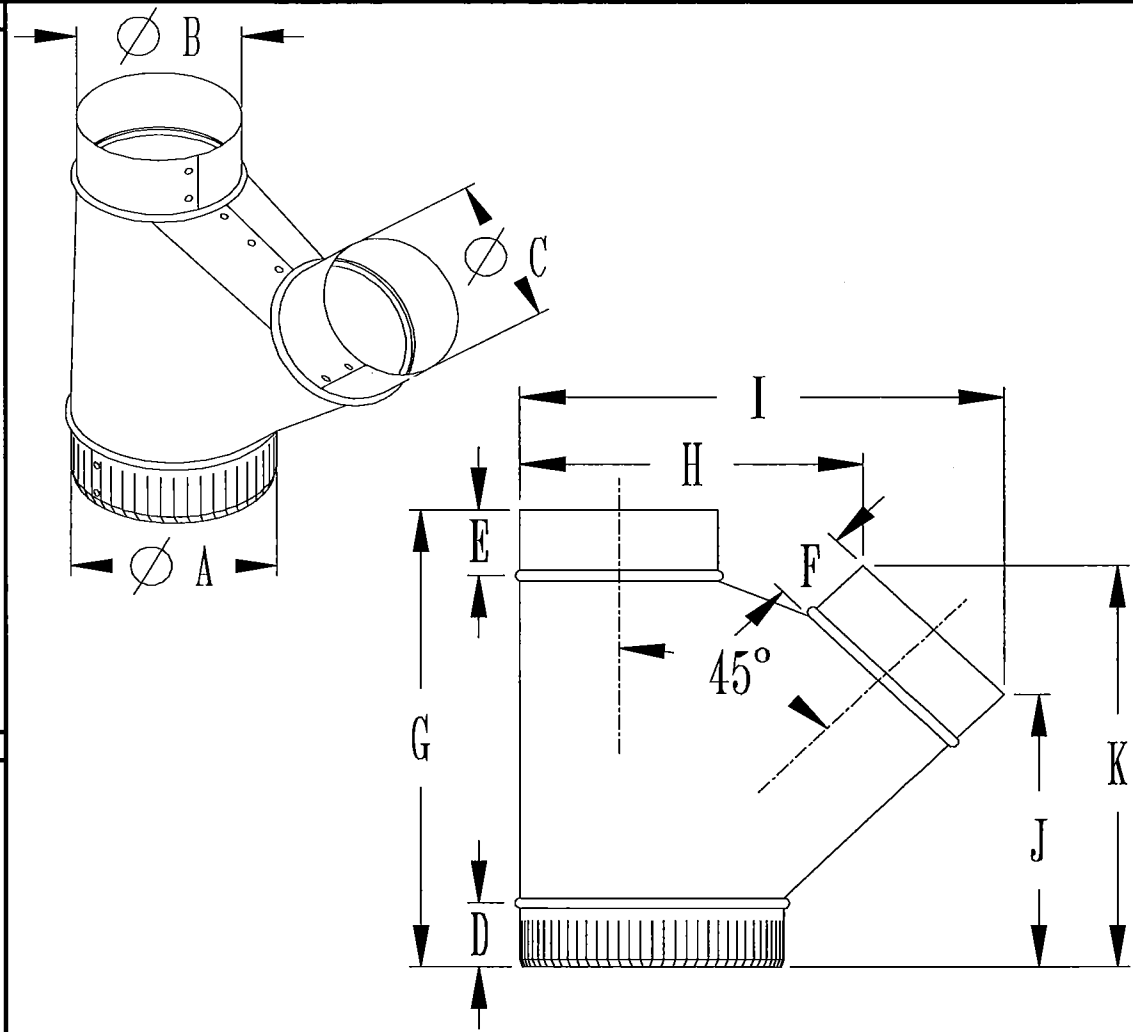

**MATERIAL SPECIFICATIONS**

HOT DIPPED GALVANIZED STEEL.  
 PER ASTM A 653 CSB.

ASSEMBLED WITH 1/8" ZINC COATED RIVETS.

BODIES ARE MINIMUM 28 GAUGE (HEAVIER GAUGES AVAILABLE)

3" - 8" COLLAR ON "A" DIMENSION = STD GAUGE MINIMUM  
 9" - 14" COLLAR ON "A" DIMENSION = 28 GAUGE MINIMUM

**OPTIONS**

26 GAUGE & 24 GAUGES AVAILABLE

AVAILABLE WITHOUT CRIMP  
 AVAILABLE ALL CRIMP

JOB: \_\_\_\_\_  
 LOCATION: \_\_\_\_\_  
 CONTRACTOR: \_\_\_\_\_  
 ENGINEER: \_\_\_\_\_  
 NOTES: \_\_\_\_\_



325 COMMERCE DRIVE  
 MT VERNON, OH 43050  
 800-253-8236

**SPECIFICATION DATA SHEET**

DATE: 7-17-13 PAGE: 2  
 PREPARED BY: RL

**MODEL NO. 529**

**WYE**

STANDARD MODEL

**DIMENSIONS**

SIZE			D	E	F	G	H	I	J	K
A x B x C	D	E	F	G	H	I	J	K		
7" x 6" x 3"	2 1/4"	2"-HEM	2 1/4"	10 7/8"	10 3/16"	12 5/16"	7 5/16"	9 7/16"		
7" x 6" x 4"	2 1/4"	2"-HEM	2 1/4"	12 5/16"	10 3/16"	13"	8"	10 7/8"		
7" x 6" x 5"	2 1/4"	2"-HEM	2"-HEM	13 1/4"	9 7/8"	13 3/8"	8 3/8"	11 7/8"		
7" x 6" x 6"	2 1/4"	2"-HEM	2"-HEM	14 11/16"	9 7/8"	14 1/16"	9 1/16"	13 5/16"		
7" x 7" x 4"	2 1/4"	2"-HEM	2 1/4"	13 1/4"	11 3/16"	14"	9"	11 13/16"		
7" x 7" x 5"	2 1/4"	2"-HEM	2"-HEM	14 1/4"	10 7/8"	14 3/8"	9 3/8"	12 15/16"		
7" x 7" x 6"	2 1/4"	2"-HEM	2"-HEM	15 5/8"	10 7/8"	15 1/8"	10 1/8"	14 5/16"		
7" x 7" x 7"	2 1/4"	2"-HEM	2"-HEM	13 13/16"	9 11/16"	14 5/8"	8"	13"		
8" x 6" x 6"	2 1/4"	2"-HEM	2"-HEM	13 1/2"	9 3/4"	14"	8"	12 1/4"		
8" x 7" x 4"	2 1/4"	2"-HEM	2 1/4"	12 5/16"	11 3/16"	14"	8"	10 7/8"		
8" x 7" x 6"	2 1/4"	2"-HEM	2"-HEM	14 5/8"	10 7/8"	15 1/16"	9 1/16"	13 3/8"		
8" x 7" x 5"	2 1/4"	2"-HEM	2"-HEM	13 1/4"	10 7/8"	14 3/8"	8 3/8"	11 15/16"		
8" x 7" x 6"	2 1/4"	2"-HEM	2"-HEM	14 5/8"	10 7/8"	15 1/16"	9 1/8"	13 5/16"		
8" x 8" x 4"	2 1/4"	2"-HEM	2 1/4"	13 5/16"	12 1/4"	15"	9 1/16"	11 7/8"		
8" x 8" x 5"	2 1/4"	2"-HEM	2"-HEM	14 1/4"	11 7/8"	15 3/8"	9 3/8"	11 15/16"		
8" x 8" x 6"	2 1/4"	2"-HEM	2"-HEM	15 5/8"	11 7/8"	16 1/8"	10 1/8"	14 3/8"		
8" x 8" x 8"	2 1/4"	2"-HEM	2"-HEM	15"	10 13/16"	16 1/2"	8 7/16"	14 1/16"		
9" x 7" x 5"	2 1/4"	2"-HEM	2"-HEM	12 5/16"	10 7/8"	14 7/16"	7 7/16"	11"		
9" x 7" x 6"	2 1/4"	2"-HEM	2"-HEM	13 9/16"	10 7/8"	15 1/8"	8"	12 1/4"		
9" x 7" x 7"	2 1/4"	2"-HEM	2"-HEM	15 1/16"	10 7/8"	15 13/16"	8 13/16"	13 3/4"		
9" x 8" x 5"	2 1/4"	2"-HEM	2"-HEM	14 1/8"	12 1/2"	16"	9"	12 1/2"		
9" x 8" x 7"	2 1/4"	2"-HEM	2"-HEM	16 15/16"	12 7/16"	17 7/16"	10 3/8"	15 3/8"		
9" x 8" x 8"	2 1/4"	2"-HEM	2"-HEM	17 1/2"	11 7/8"	17 1/2"	10 1/2"	16 3/16"		
9" x 9" x 9"	2 1/4"	2 1/4"	2 1/4"	20 3/8"	12 7/8"	19 1/4"	12 3/8"	18 3/4"		

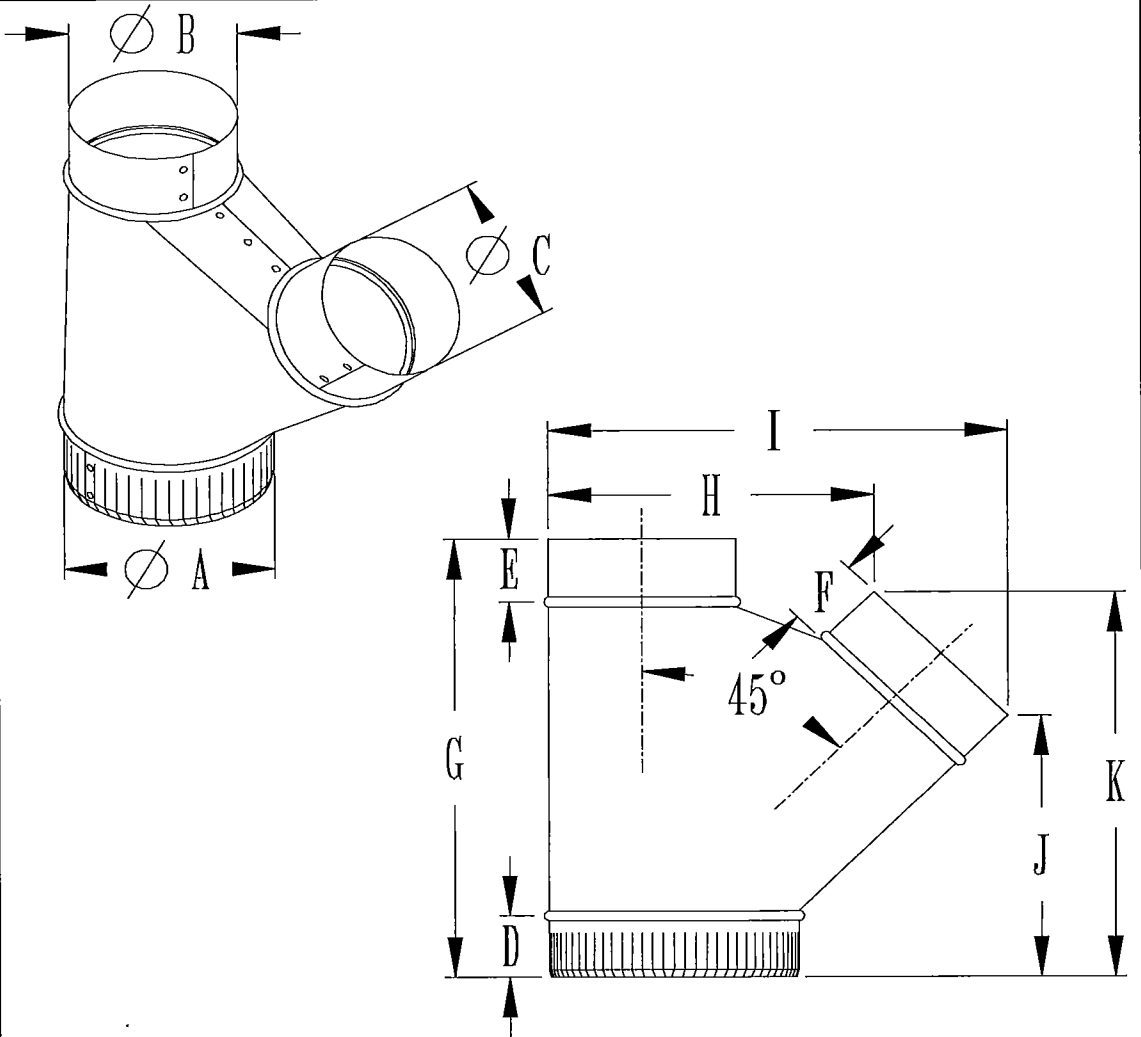

**MATERIAL SPECIFICATIONS**

HOT DIPPED GALVANIZED STEEL.  
 PER ASTM A 653 CSB.

ASSEMBLED WITH 1/8" ZINC COATED RIVETS.

BODIES ARE MINIMUM 28 GAUGE (HEAVIER GAUGES AVAILABLE)

3" - 8" COLLAR ON "A" DIMENSION = STD GAUGE MINIMUM

9" - 14" COLLAR ON "A" DIMENSION = 28 GAUGE MINIMUM

**OPTIONS**

26 GAUGE & 24 GAUGES AVAILABLE

AVAILABLE WITHOUT CRIMP

AVAILABLE ALL CRIMP

JOB: \_\_\_\_\_  
 LOCATION: \_\_\_\_\_  
 CONTRACTOR: \_\_\_\_\_  
 ENGINEER: \_\_\_\_\_  
 NOTES: \_\_\_\_\_