

**CALOWAMB018A00 –
CALOWAMB023A00
CALOWAMB037A00-
CALOWAMB042A00**

**SPLIT SYSTEM AC UNITS
ACCESSORY MOTORMASTER® I
HEAD PRESSURE CONTROLLER
15 & 20 TONS**

Installation Instructions

IMPORTANT: Read these instructions completely before attempting to install this accessory.

SAFETY CONSIDERATIONS

Installation, start-up and servicing of this equipment can be hazardous due to system pressures, electrical components and equipment location (roofs, elevated structures, etc.)

Untrained personnel can perform the basic maintenance functions. All other operations should be performed by trained service personnel. When working on air-conditioning equipment, observe precautions in the literature, tags and labels attached to the unit, and other safety precautions that may apply.

Follow all safety codes. Wear safety glasses and work gloves.

Recognize safety information. This is the safety-alert symbol . When you see this symbol on the unit and in instructions or manuals, be alert to the potential for personal injury.

Understand the signal words DANGER, WARNING, and CAUTION. These words are used with the safety-alert symbol. DANGER identifies the most serious hazards which **will** result in severe personal injury or death. WARNING signifies a hazard which **could** result in personal injury or death. CAUTION is used to identify unsafe practices which **may** result in minor personal injury or product and property damage. NOTE is used to highlight suggestions which **will** result in enhanced installation, reliability, or operation.

WARNING

ELECTRICAL SHOCK HAZARD

Failure to follow this warning could cause personal injury or death.

Before performing service or maintenance operations on unit, turn off main power switch to unit and install lockout tag. Ensure electrical service to rooftop unit agrees with voltage and amperage listed on the unit rating plate.

CAUTION

EQUIPMENT DAMAGE HAZARD

Failure to follow this caution may result in damage to equipment.

When removing panels from the unit, be careful not to damage the roof or other surfaces with the panels.

GENERAL

Motormaster I solid--state head pressure control regulates outdoor (condenser) fan speed during Cooling mode operation. A temperature sensor, mounted on a return bend of the outdoor (condenser) coil, controls the speed of approved outdoor (condenser) fan motors in order to maintain a constant head pressure in the outdoor (condenser) coil. When properly installed, the control will maintain the appropriate head pressure at low ambient temperatures down to -20°F (-28°C).

On size 16/180/181 and 25/240/241 units, the single Motormaster I control is connected to two outdoor (condenser) fan motors – OFM1 and OFM3. The additional fan motors – OFM2 (all units) and OFM4 (size 25/240/241 only) -- are staged off at mild ambient temperatures (below 40°F (6°C) by low ambient temperature switch LAS through relay LAR.

575-V ONLY: TRANSFORMER WITH 460-V MOTORS AND CONTROL -- On 575-v units, the 575-v motors installed in positions OFM1 and OFM3 are replaced with 460-v fan motors, powered through a stepdown (575-v to 460-v) transformer and controlled through a 460-v Motormaster controller.

PACKAGE CONTENTS

CALOWAMB0												ITEM
18A00	19A00	20A00	21A00	22A00	23A00	37A00	38A00	39A00	40A00	41A00	42A00	
1 qty	1 qty	1 qty	1 qty	1 qty	1 qty	1 qty	1 qty	1 qty	1 qty	1 qty	1 qty	Motormaster I Control/Sensor
		1 qty			1 qty			1 qty			1 qty	Transformer, 575V to 460V
1 qty	1 qty	1 qty	1 qty	1 qty	1 qty	1 qty	1 qty	1 qty	1 qty	1 qty	1 qty	Mounting Bracket
2 qty	2 qty	2 qty	2 qty	2 qty	2 qty	2 qty	2 qty	2 qty	2 qty	2 qty	2 qty	Outdoor Fan Motor
1 qty	1 qty	1 qty	1 qty	1 qty	1 qty	1 qty	1 qty	1 qty	1 qty	1 qty	1 qty	Low Ambient Temperature Switch
		1 qty			1 qty			1 qty			1 qty	Fan Motor Capacitor
1 qty	1 qty	1 qty	1 qty	1 qty	1 qty	1 qty	1 qty	1 qty	1 qty	1 qty	1 qty	Low Ambient Relay
1 qty	1 qty	1 qty	2 qty	2 qty	2 qty	1 qty	1 qty	1 qty	2 qty	2 qty	2 qty	Time Delay Relay
yes	yes	yes	yes	yes	yes	yes	yes	yes	yes	yes	yes	Mounting Supplies
yes	yes	yes	yes	yes	yes	yes	yes	yes	yes	yes	yes	Wiring Supplies

PACKAGE USAGE

20 Ton	Single Circuit	208/230-3-60	CALOWAMB018A00
20 Ton	Single Circuit	460-3-60	CALOWAMB019A00
20 Ton	Single Circuit	575-3-60	CALOWAMB020A00
20 Ton	Dual Circuit	208/230-3-60	CALOWAMB021A00
20 Ton	Dual Circuit	460-3-60	CALOWAMB022A00
20 Ton	Dual Circuit	575-3-60	CALOWAMB023A00
15 Ton	Single Circuit	208/230-3-60	CALOWAMB037A00
15 Ton	Single Circuit	460-3-60	CALOWAMB038A00
15 Ton	Single Circuit	575-3-60	CALOWAMB039A00
15 Ton	Dual Circuit	208/230-3-60	CALOWAMB040A00
15 Ton	Dual Circuit	460-3-60	CALOWAMB041A00
15 Ton	Dual Circuit	575-3-60	CALOWAMB042A00

CALOWAMB

INSTALLATION

Check voltage of kit parts against unit voltage. Before starting, check controller and motor voltage against unit voltage.

NOTE: 575-v units use 460-v controller and motors with stepdown autotransformer.

Changing outdoor fan motors (all units)

1. Disconnect power to the unit. Lock-out/tag-out.
2. Remove main access panel and control box cover.
3. At capacitor CAP1.
4. Disconnect all OFM BLK wires at TB3. Retain the BLK wire to relay OFR.
5. Identify fan-motor positions OFM1 and OFM3; refer to Fig. 11 and Fig. 12.
6. Trace the motor leads from OFM1 and OFM3 to the control box. Note wire path into the control box. Pull these leads out of the control box.
7. Remove the screws securing the OFM1 and OFM3 fan grilles from the unit top cover. Save these screws.
8. Remove the fan grille assemblies at OFM1 and OFM3 by lifting the assemblies straight up until the prop blades clear the fan deck. Invert the grille assemblies and place on a support surface.
9. Measure and record the dimension of the top edge of the prop blade to the grille.
10. For OFM1 and OFM3 assemblies, remove the prop fan from the motor shaft.
11. Observe the orientation of the fan motor wires at the grille and motor shell opening. Remove the fan motors from the grille center plate.
12. Attach the motors from the accessory kit to the grilles. Do not overtighten the nuts onto the motor throughbolt ends. Torque. Secure wires to grille as noted in step 11.
13. Mount the prop fan onto the motor shaft. Locate the prop at the distance from the grille measured in step 9 above. If the prop blade contacts the motor housing, adjust prop position until the prop clears the motor by 1/2-in. (13 mm). Torque the prop set screws to in-lbs .
14. Position the OFM1 grille assembly over its top panel opening and carefully insert the motor wires and prop through the opening and lower into place. Secure using screws removed in step 7. Repeat for OFM3 grille assembly.
15. Rotate the prop fan to ensure there is no interference or contact with unit piping or motor wiring.
16. Route the motor leads into the control box as noted in step 6.

Motormaster installation (all units) (ref Fig.

1.)

1. Locate the mounting plate in the kit and attach to unit side panel per Fig. 1 using the sheet metal screws included with the accessory.
2. Mount the Motormaster controller onto the mounting plate using four screws. The controller must be

mounted vertically with leads at the bottom. To ensure electrical ground, use the serrated head mounting screws provided.

3. Route the Motormaster sensor cord to the Circuit 1 coil (right of compressors).
4. Route the RED and BLK wires from the Motormaster controller into the unit control box.
5. For 575v units, the supplied transformer (575v to 460v) also mounts to the bracket.

Mount LAR relay

Accessory packages for these units include an LAR relay. Refer to Component Arrangement view on the unit wiring diagram; mount the relay in the unit control box in LAR position using screws provided.

Mount Fan Staging Temperature Switch and Wire (all units)

1. Mount the low ambient fan staging temperature switch (LAS) to the top of the service valve housing (see Fig. 2).
2. Connect one of the YEL (LAS) wires to Y1 on the connection board (TB) and connect the other YEL wire to terminal 1 of the low ambient relay (LAR). See Fig. 3-6 for details, depending on unit type and voltage.
3. Route YEL wires into unit control box.

Control Box Changes and Wiring

Refer to Component Location view on unit wiring label to determine location in control box for new components.

575-units: Replace CAP1

1. Disconnect the YEL wire at CAP1 center terminal.
2. Unscrew the capacitor strap at CAP1 carefully so that it can be reused.
3. Remove the capacitor and store it in a safe place or discard properly.
4. Using the capacitor strap, safely secure the new 10mfdx10mfd capacitor in the original capacitor location.
5. Reconnect the YEL wire at the capacitor center terminal.

Wiring Connections

Motormaster/OFM1/OFM3/OFR Wiring

1. Rewire unit for new or replaced parts using the provided wiring diagrams (see Fig. 3-6) and the unit label wiring diagram for details.
2. Locate the YEL and BRN leads from new OFM1 and OFM3; pull to capacitor CAP1.
3. Connect both YEL leads at CAP1 terminal C.
4. Connect BRN lead from OFM1 at CAP1 terminal F.
5. Connect BRN lead from OFM3 at CAP1 terminal H.

Sensor Location

Unit with Copper Tube Coil

Sensor is attached to a transfer header tube on Circuit 1 coil, located to the right of the compressors. Refer to Figures for specific tube location. Use machine screw and nut to secure sensor clamp to the tube.

Wind Baffles

Wind baffles are required to prevent wind cross currents from causing abnormally low condensing temperatures.

Use 20--gauge sheet metal to fabricate wind baffles (see Fig. 9 and Table 1) and mounting brackets (see Fig. 10).

NOTE: Mounting brackets are for use on 15 ton units only.

Install the wind baffles as show in Fig. 11, for 15 ton units and Fig. 12, for 20 ton units.

6. Reconnect power to the unit.
7. Mount the supplied time delay relay(s) (TDR) in the control box. See Fig. 7 & 8 for location(s).
8. Rewire unit for the new or replaced parts (outdoor fan motors, Motormaster control, plus time delay relays, low ambient relay, low ambient temperature switch and 575 to 460V transformer, as applicable). Use the provided wiring diagrams (see Fig. 3-6) and the unit label wiring diagram for details.

NOTE: The 575V to 460V transformer (HT01AH858) is used as an auto--transformer (buck boost transformer), not as a traditional step down isolation transformer therefore it must be wired as per Fig. 4 (15 ton units) or Fig. 6 (20 ton units).

9. Coil up all excess wire and secure it next to the controller.

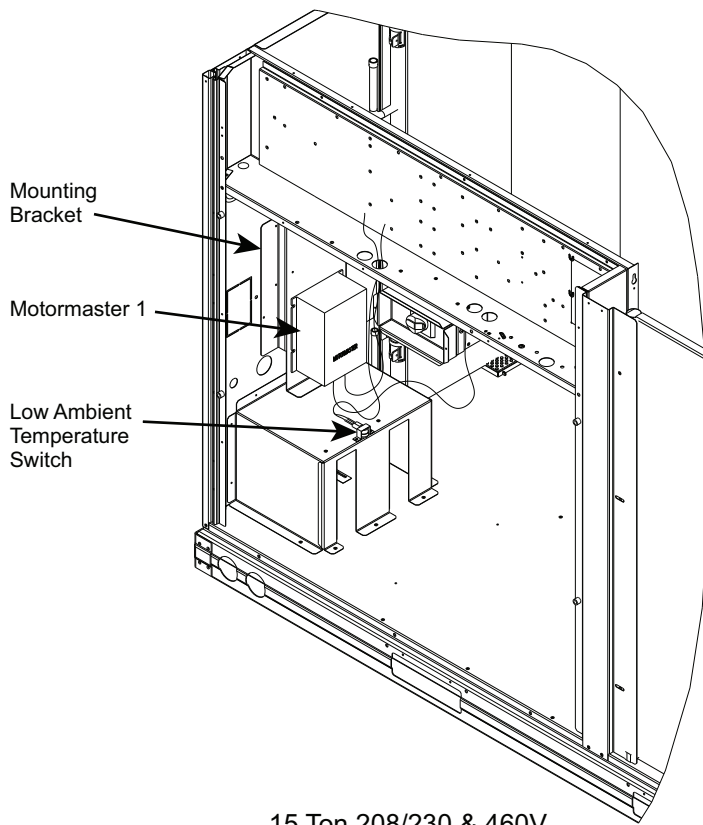

15 Ton 208/230 & 460V

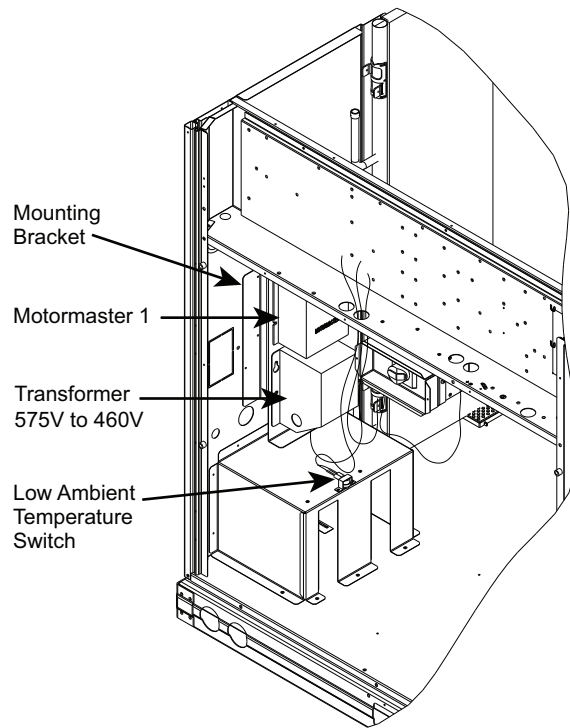

15 Ton 575V

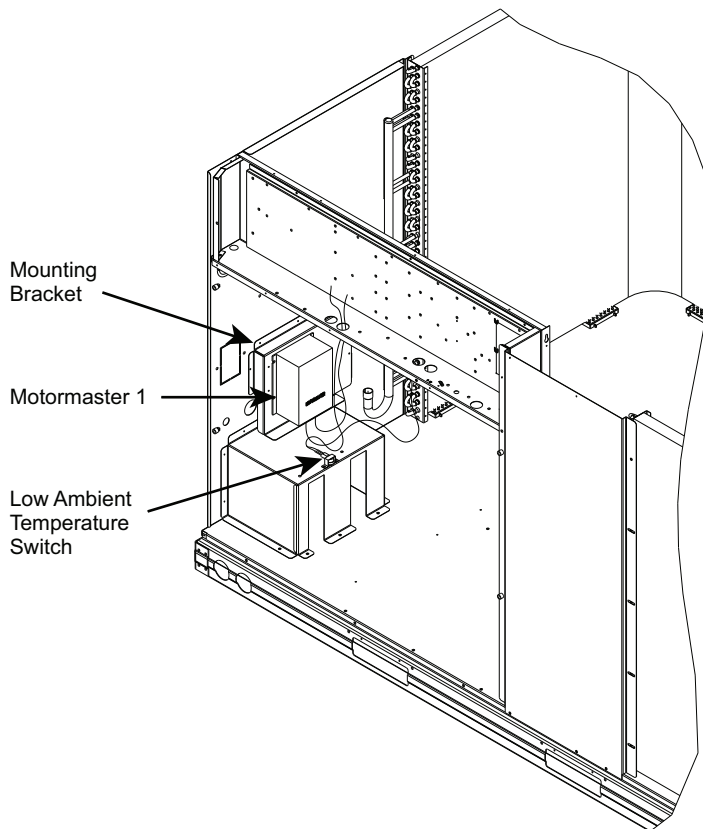

20 Ton 208/230 & 460V

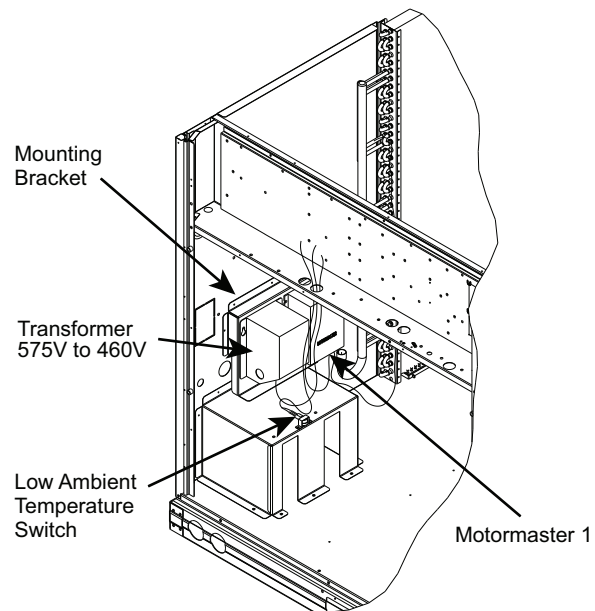

20 Ton 575V

Fig. 1 - Motormaster Controller Mounting

C10525

Motormaster Sensor -
Must be positioned
on Vapor Stub of
Circuit 1 coil only.

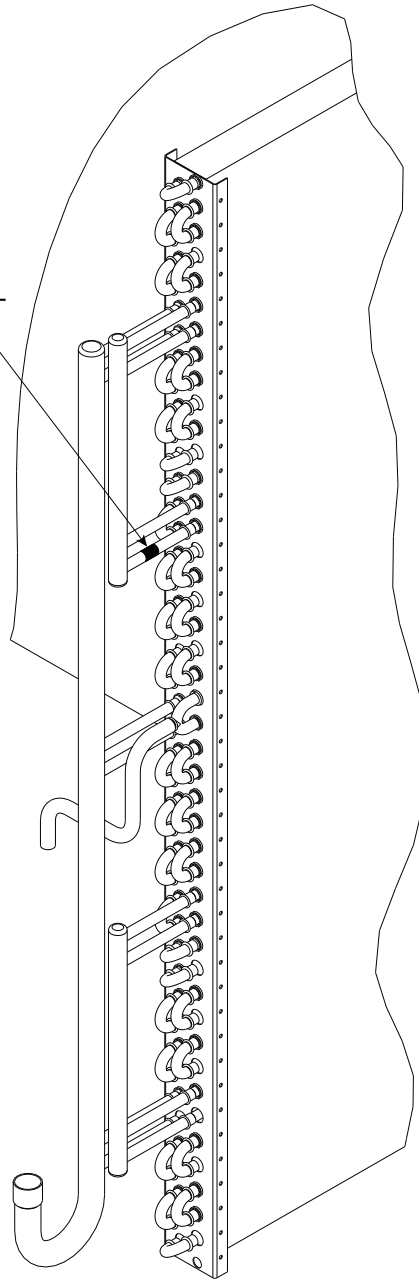

Motormaster Sensor Location -
RTPF Coil Units Only:
38AUZ*16/25 & 38AUD*16/25
569J*16/25A & 569J*16/25D

Fig. 2 - Sensor Location

C13504

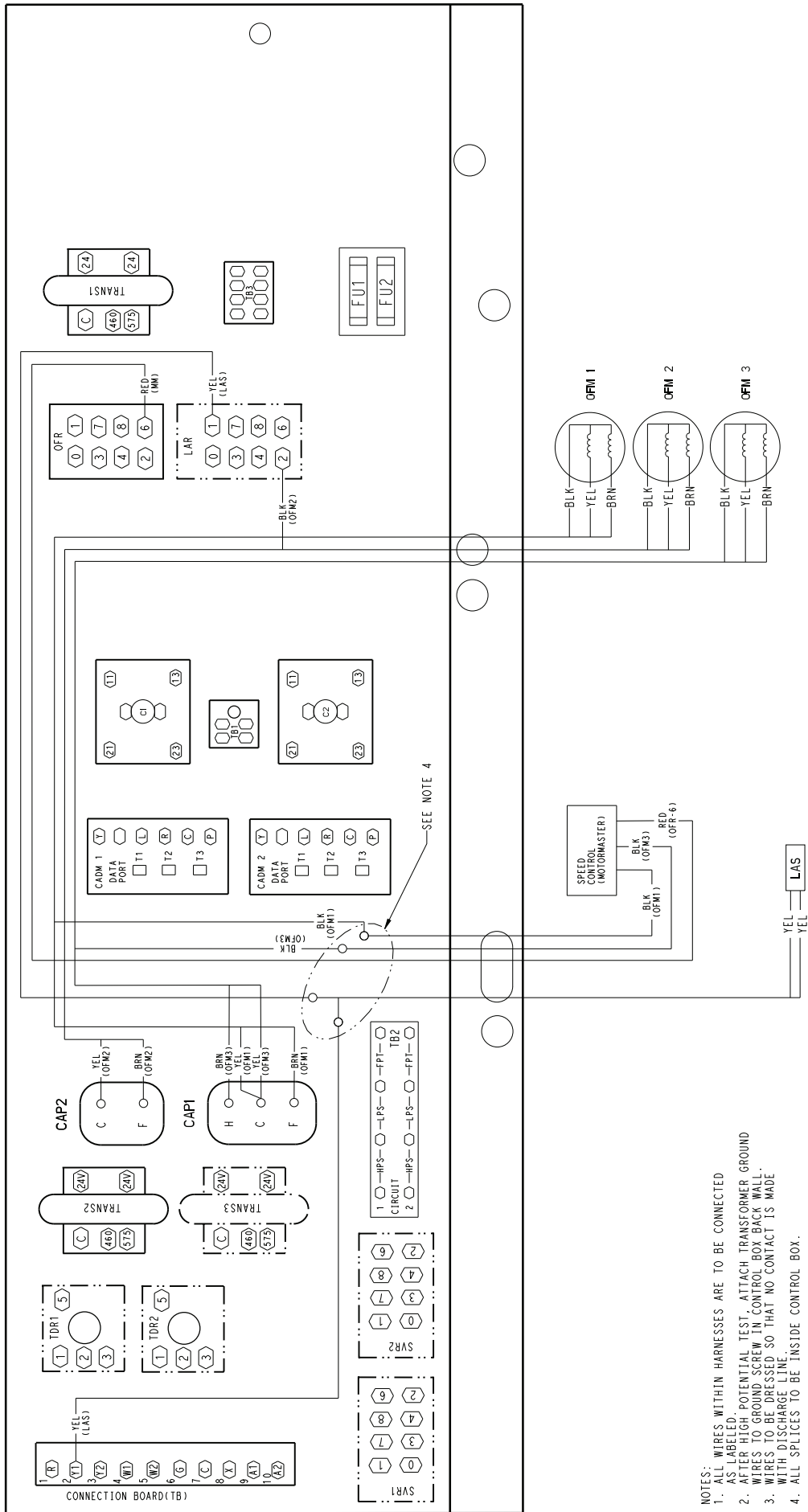

- NOTES:
1. ALL WIRES WITHIN HARNESES ARE TO BE CONNECTED AS LABELED. POTENTIAL TEST. ATTACH TRANSFORMER GROUND.
 2. WIRES TO GROUND SCREW IN CONTROL BOX BACK WALL.
 3. WIRES TO BE DRESSED SO THAT NO CONTACT IS MADE WITH DISCHARGE LINE.
 4. ALL SPLICES TO BE INSIDE CONTROL BOX.

Fig. 3 - Motormaster Wiring Details: 208/230/460V, 15 Ton Units

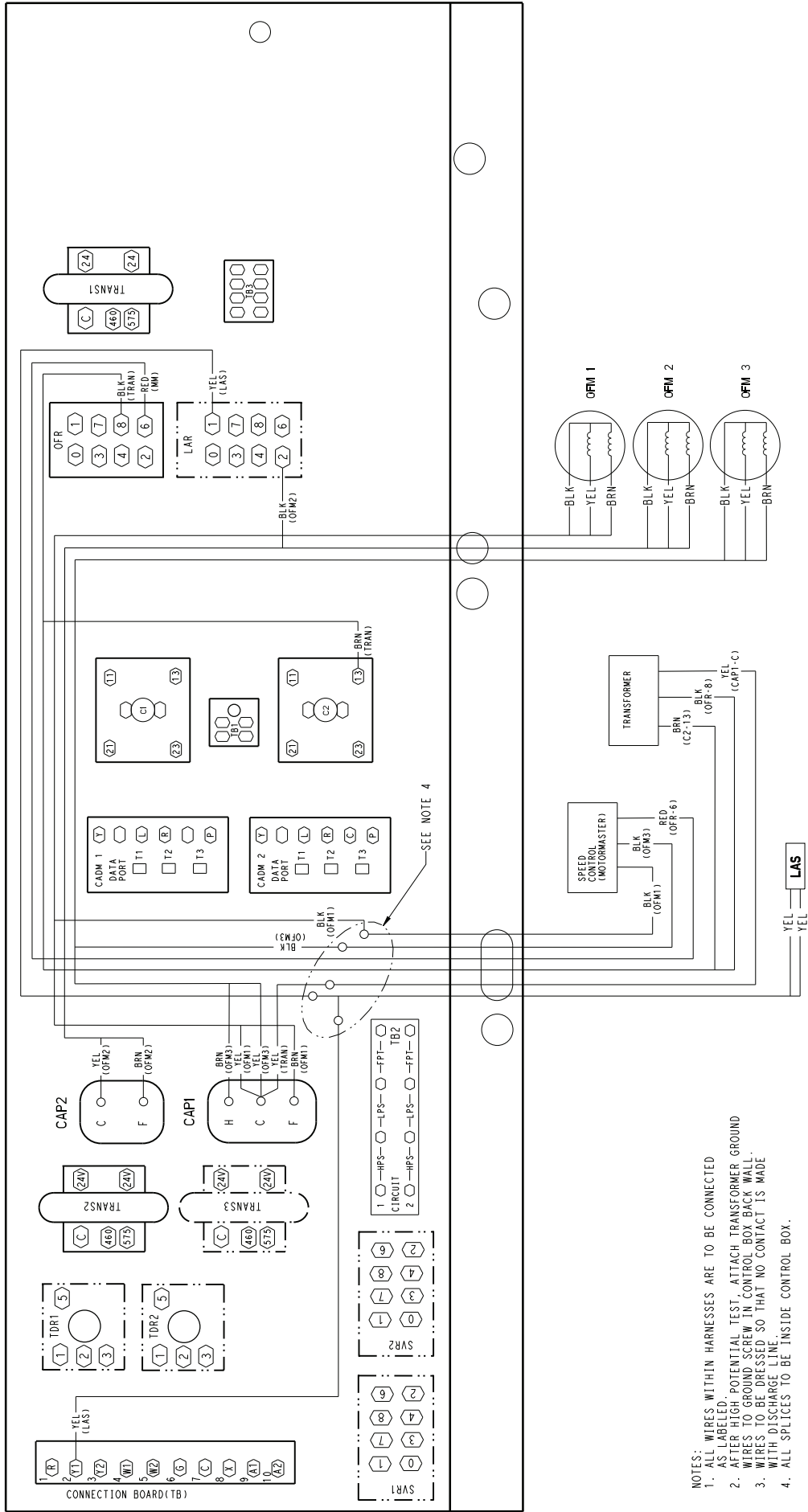

- NOTES:
1. ALL WIRES WITHIN HARNESSES ARE TO BE CONNECTED AS LABELED.
 2. AFTER HIGH POTENTIAL TEST, ATTACH TRANSFORMER GROUND WIRES TO GROUND SCREW IN CONTROL BOX BACK WALL.
 3. WIRES TO BE DRESSED SO THAT NO CONTACT IS MADE WITH DISCHARGE LINE.
 4. ALL SPLICES TO BE INSIDE CONTROL BOX.

Fig. 4 - Motormaster Wiring Details: 575V, 15 Ton Units

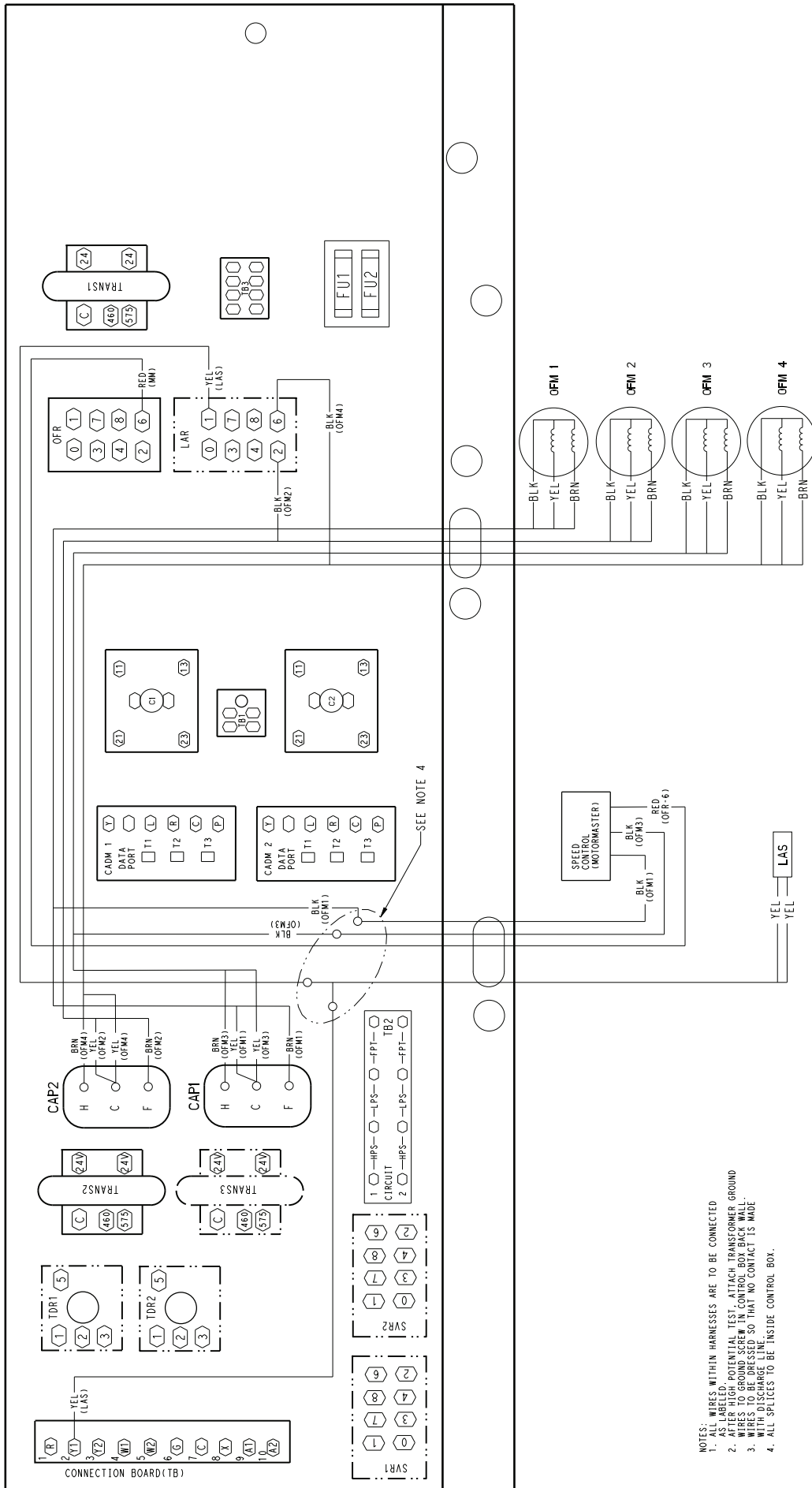

- NOTES:
1. ALL WIRES WITHIN HARNESS ARE TO BE CONNECTED AS LABELED.
 2. AFTER HIGH POTENTIAL TEST, ATTACH TRANSFORMER GROUND TO GROUND SIDE OF CONTROL BOX BACK WALL.
 3. WIRES TO BE SPACED TO GROUND SIDE OF CONTROL BOX BACK WALL WITH DISCHARGE LINE.
 4. ALL SPLICES TO BE INSIDE CONTROL BOX.

Fig. 5 - Motormaster Wiring Details: 208/230/460V, 20 Ton Units

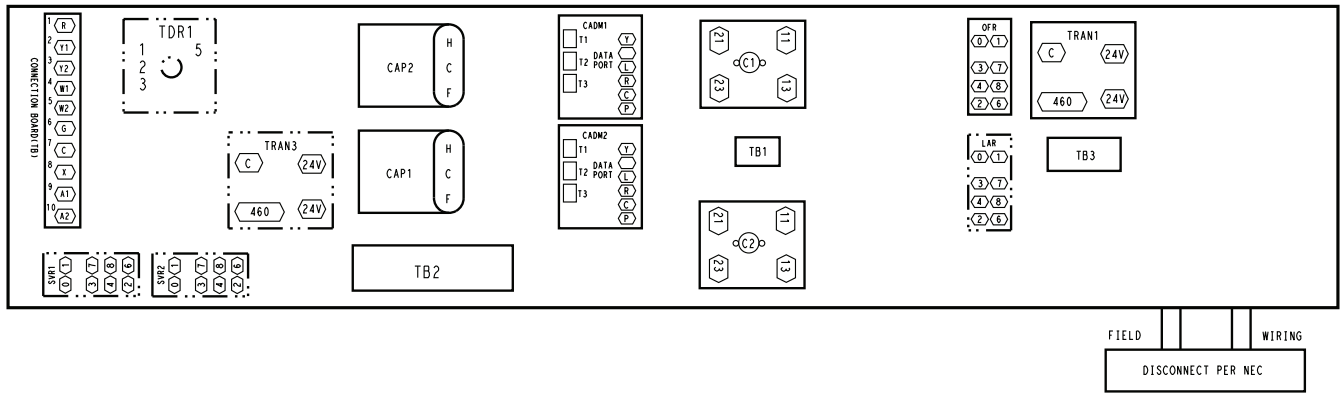

C10533

Fig. 7 - Time Delay Relay (TDR) - Location in Control Box for Single Coil Units

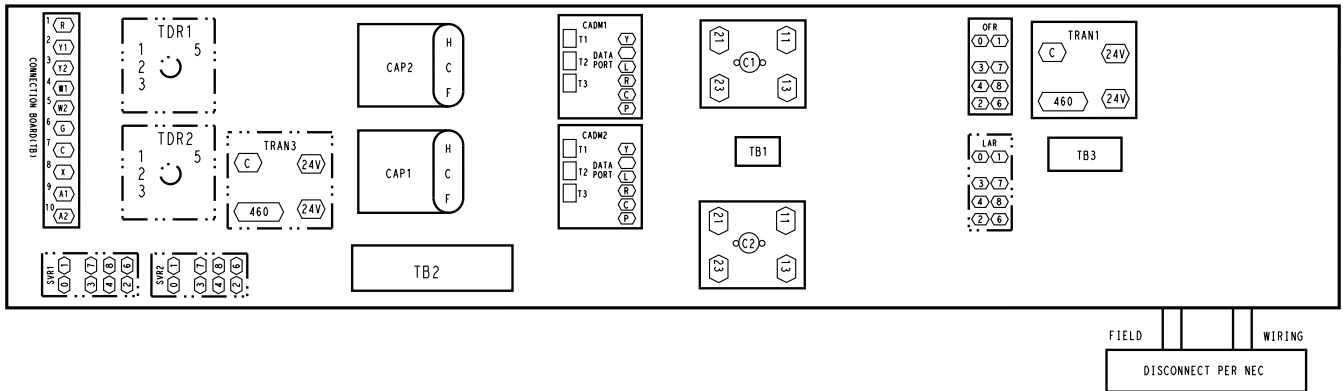

C10534

Fig. 8 - Time Delay Relay (TDR) - Location in Control Box for Dual Coil Units

Table 1 – Wind Baffle Dimension

DIMENSIONS – INCHES										
UNIT	BAFFLE	A	B	C	D	E	F	G	H	J
15 TON	LEFT SIDE	19 ³ / ₄	20 ¹ / ₂	21 ¹ / ₄	43 ¹ / ₈	8 ³ / ₈	18	27 ¹ / ₄	40	–
	BACK	80 ¹ / ₄	81	81 ³ / ₄	43 ¹ / ₈	8 ³ / ₈	18	27 ¹ / ₄	40	–
	RIGHT SIDE	38 ³ / ₄	39 ¹ / ₂	40 ¹ / ₄	43 ¹ / ₈	8 ³ / ₈	18	27 ¹ / ₄	40	–
	FRONT	34 ¹ / ₈	34 ⁷ / ₈	35 ⁵ / ₈	43 ¹ / ₈	6 ⁷ / ₈	16 ¹ / ₂	25 ³ / ₄	38 ¹ / ₂	–
20 TON	LEFT SIDE	32 ⁷ / ₈	33 ⁵ / ₈	34 ³ / ₈	43 ¹ / ₈	4 ¹ / ₄	13 ¹ / ₄	22 ¹ / ₄	31 ¹ / ₄	40 ¹ / ₄
	BACK	47 ³ / ₄	48 ¹ / ₂	49 ¹ / ₄	43 ¹ / ₈	4 ¹ / ₄	13 ¹ / ₄	22 ¹ / ₄	31 ¹ / ₄	40 ¹ / ₄
	RIGHT SIDE	61 ¹ / ₈	61 ⁷ / ₈	62 ⁵ / ₈	43 ¹ / ₈	3 ³ / ₄	12 ³ / ₄	21 ³ / ₄	30 ³ / ₄	39 ³ / ₄
	FRONT	20 ¹ / ₈	20 ⁷ / ₈	21 ⁵ / ₈	43 ¹ / ₈	3 ³ / ₄	12 ³ / ₄	21 ³ / ₄	30 ³ / ₄	39 ³ / ₄

DIMENSIONS – MM										
UNIT	BAFFLE	A	B	C	D	E	F	G	H	J
15 TON	LEFT SIDE	501	520	539	1095	212	457	694	1015	–
	BACK	2037	2056	2075	1095	212	457	694	1015	–
	RIGHT SIDE	983	1002	1021	1095	212	457	694	1015	–
	FRONT	866	885	904	1095	174	419	656	977	–
20 TON	LEFT SIDE	834	853	872	1095	108	337	565	794	1022
	BACK	1214	1233	1252	1095	108	337	565	794	1022
	RIGHT SIDE	1551	1570	1589	1095	95	324	552	781	1010
	FRONT	510	530	549	1095	95	324	552	781	1010

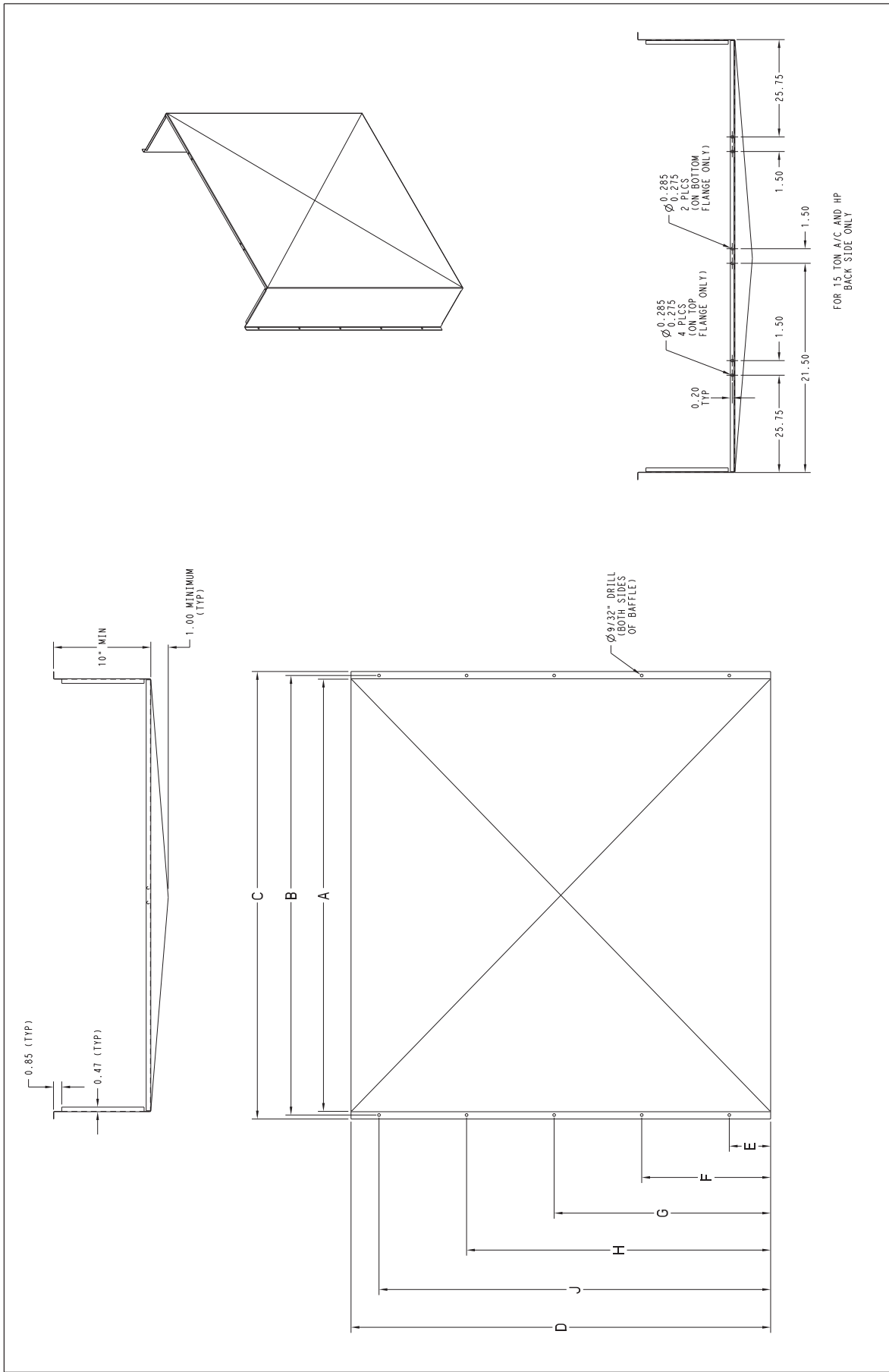

Fig. 9 - Wind Baffles - Fabrication

C10363

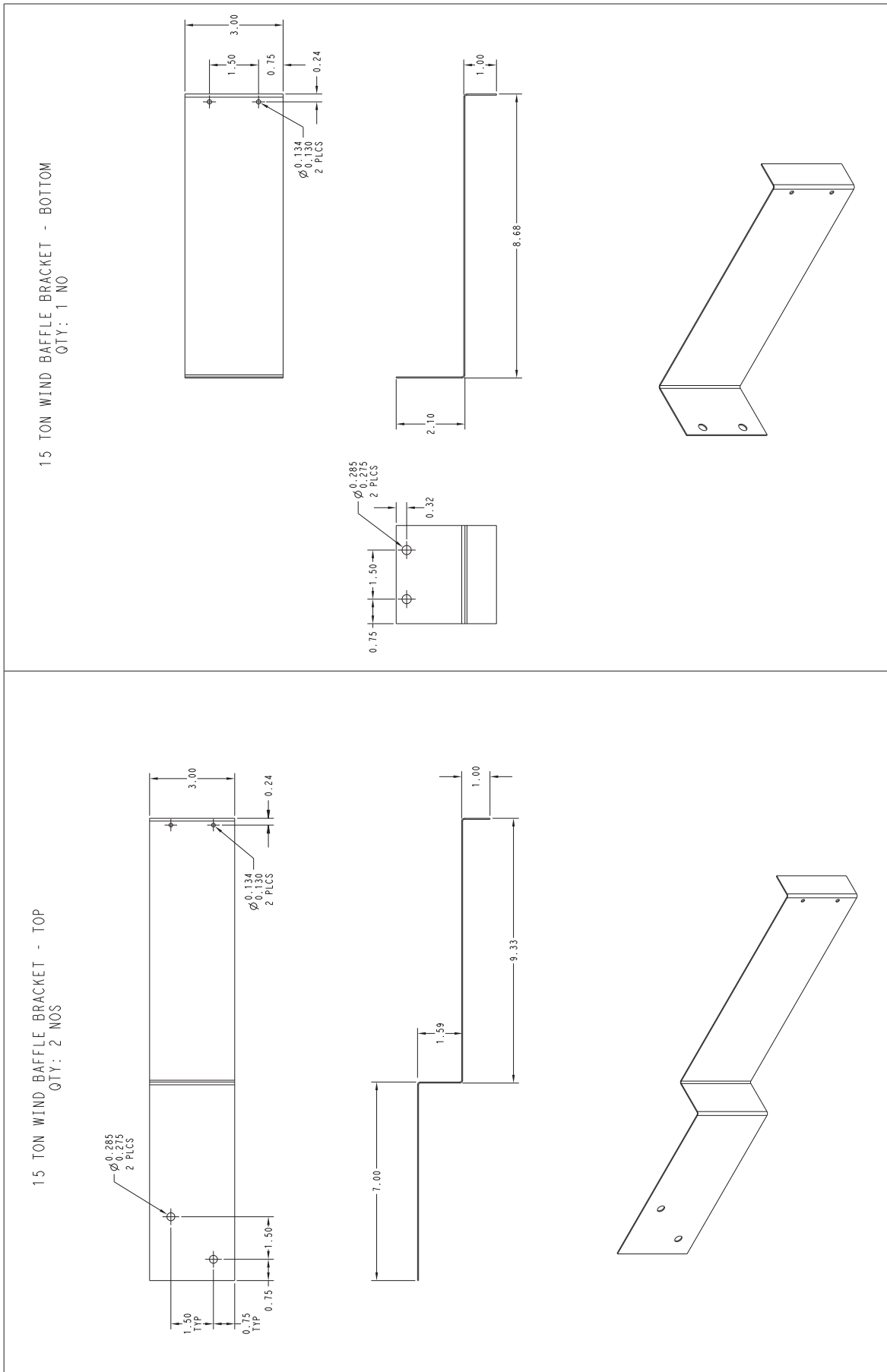

Fig. 10 - 15 Ton Wind Baffle Brackets - Fabrication

C10366

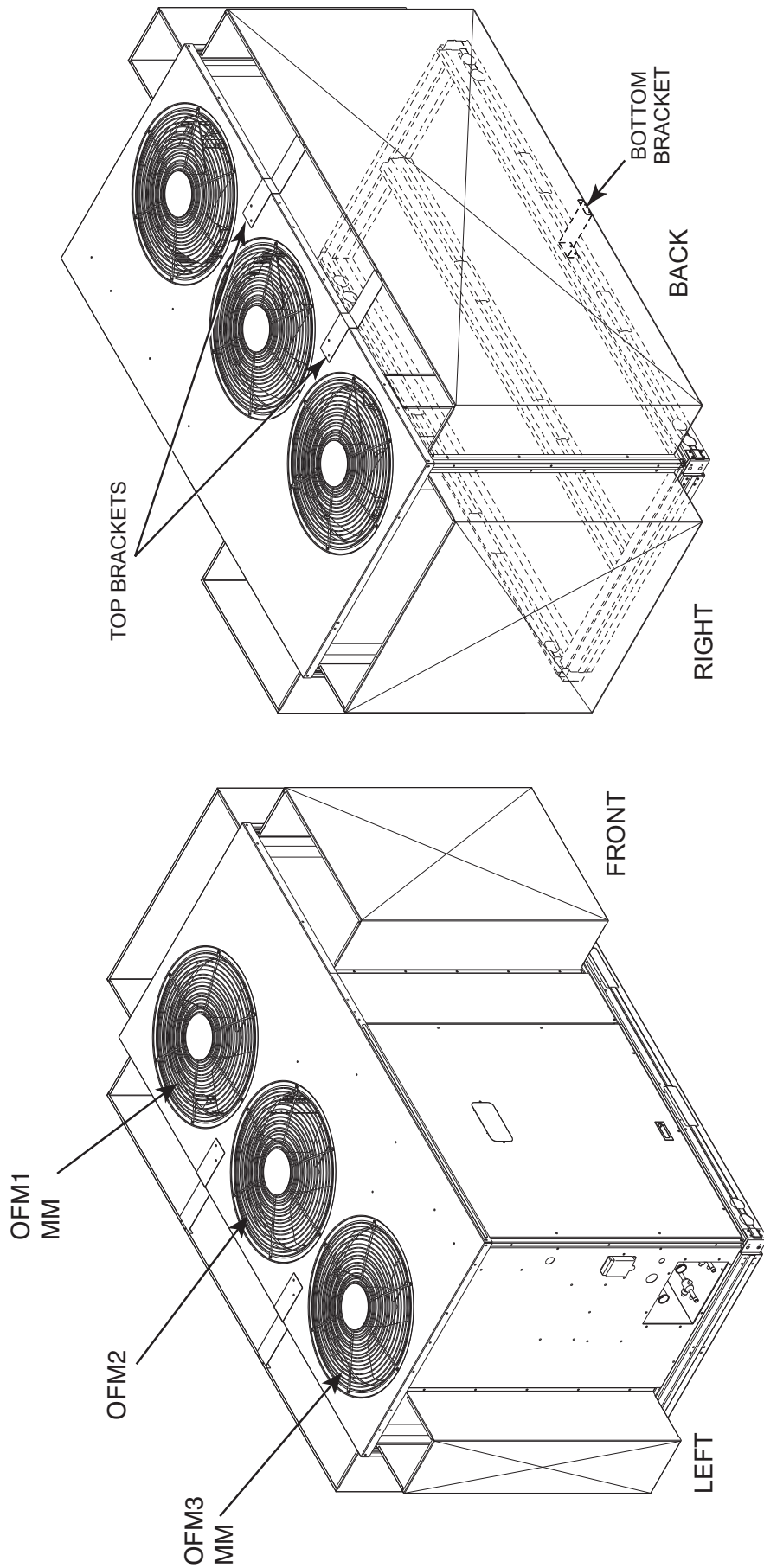

Fig. 11 - Wind Baffle Installation — 15 Ton Units

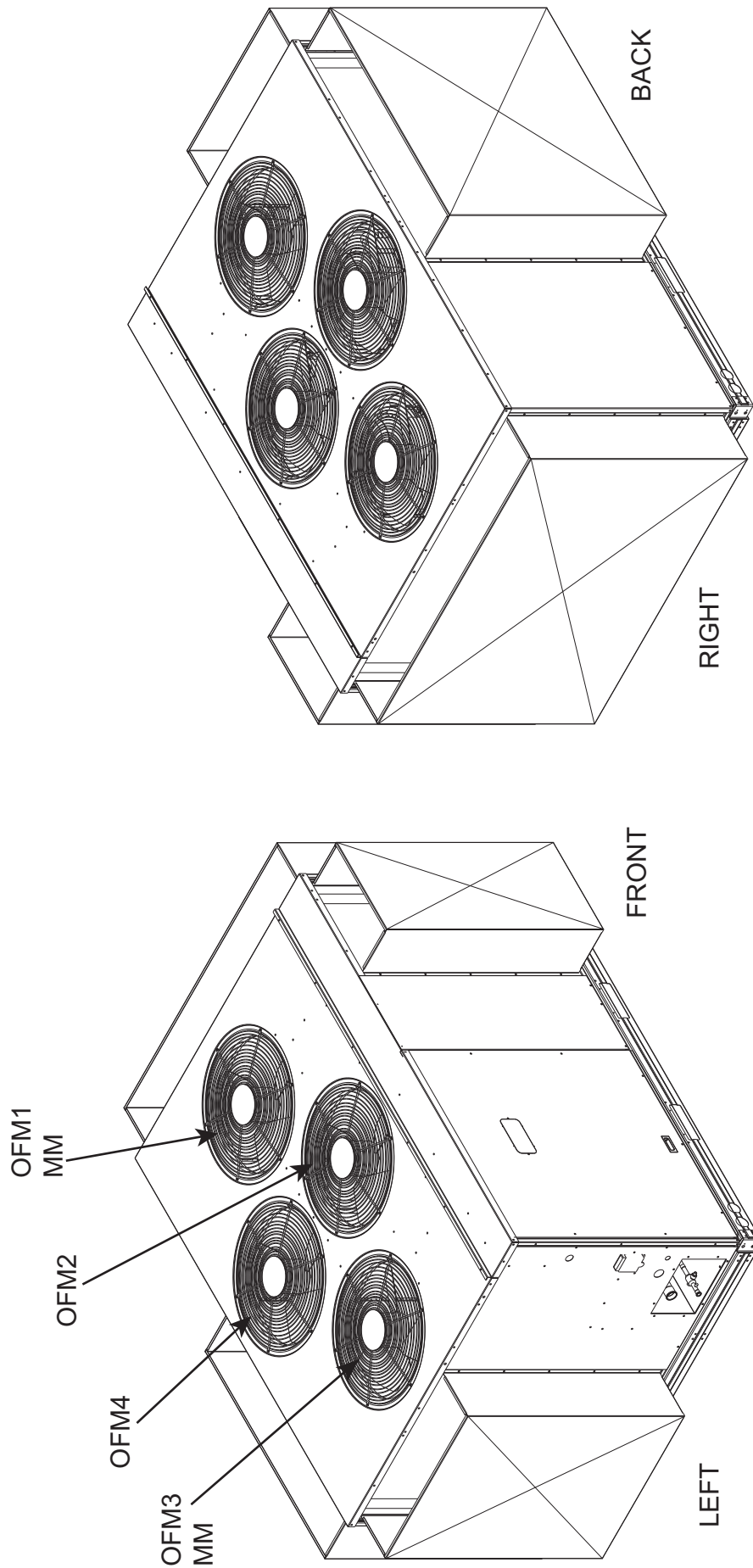

Fig. 12 - Wind Baffle Installation — 20 Ton Units

38AUD/AUZ OPERATING SEQUENCE

Fan on/off control in cooling-only units is provided by an outdoor fan relay (OFR).

In cooling mode, fan motor speed of outdoor motors OFM1 and OFM3 is regulated by the speed control temperature sensor on outdoor coil 1 for a minimum coil condensing temperature of approximately 100°F (38°C) at higher outdoor ambient temperature and 80°F (27°C) at lower ambient. Additionally, outdoor fan motor OFM2 and OFM4 are turned on/off by the low ambient temperature switch, LAS, operating the low ambient relay (LAR). The LAS control temperatures are open 42°F +/- 5°F, close 57°F +/- 5°F (open 5.5°C +/- 2.8°C, close 13.9°C +/- 2.8°C).

To override the speed control for full fan speed operation during service or maintenance, either:

- a. Remove sensor and place in hot water >120°F (>49°C), or
- b. Rewire to bypass control by connecting speed control input and output power wires.

CALOWAMB

TROUBLESHOOTING

OBSERVATION	POSSIBLE REMEDY
Fans won't start	All fans: Check power & wiring Check outdoor fan relay (OFR) OFM1, OFM3 only: Check speed control sensor location Check speed sensor resistance OFM2, OFM4 only: Check low ambient switch (LAS) Check low ambient relay (LAR)
Cooling – Center outdoor fans (OFM2, OFM4) off below approximately 60°F (16°C) outdoor ambient.	Normal operation
Cooling – Center outdoor fans (OFM2, OFM4) not on above approximately 60°F (16°C) outdoor ambient	Check low ambient switch (LAS) Check low ambient relay (LAR)
Cooling – Slow fan speed for outer fans (OFM1, OFM3) at start or during low outdoor ambient	Normal operation
Cooling – Slow fan speed for outer fans (OFM1, OFM3) above 85°F (29°F) outdoor ambient (should be full speed)	Check speed control sensor location Check speed control sensor resistance Check fan motor capacitor
Cooling – motor current into speed control is greater than motor name-plate FLA	Normal operation Up to 30% higher A at partial speed at low ambient

Speed Control Sensor Resistance —

TEMPERATURE		RESISTANCE
°F +/-2°F°	°C +/-1C	Ohms, nominal
-22	-30	88350
-4	-20	48485
14	-10	27650
32	0	16325
50	10	9950
68	20	6245
77	25	5000
86	30	4028
104	40	2663
122	50	1801
140	60	1244
158	70	876