

Supply and Sound Attenuator Duct



UPC-25/225



UPC-26/226

Model Number (Unico Part Code)

UPC 25 R4 - 1

Quantity Per Box

Rated R-Factor*
 R-3.3 (Standard)
 R-4.2
 R-6.0
 R-8.0

Rev. Code (optional)

Diameter, Inside
 25 = 2 inch Supply Tubing
 225 = 2.5 inch Supply Tubing
 26 = 2 inch Supply Tubing
 226 = 2.5 inch Supply Tubing

110693

General

The aluminum supply tubing and sound attenuator is an insulated flexible air duct. The insulation is designed to prevent condensation from forming on the outside of the duct and to minimize thermal losses to the surrounding environment.

The supply and sound attenuator tubing is offered in two diameters with several different choices of insulation thickness. In most cases, the standard supply tubing should be used. However, for extremely cold or humid environments or where the local building code requires a specific R-factor and the duct is installed in an unconditioned space, use the R4, R6, or R8 products. The R4, R6, and R8 ducts have thicker and heavier insulation than the standard model to reduce thermal losses.

Application

The Unico sound attenuator significantly reduces sound from the outlets. The aluminum supply tubing does not. Therefore, for proper noise control, it is recommended to use at least 3 feet (1 m) of the sound attenuator at the end of every supply branch run. Optionally, the entire branch duct can be made of one or more lengths of the sound attenuator. For long duct runs, the aluminum core tubing is stronger than the sound attenuator core and is best to construct the branch duct using almost all aluminum supply tubing with a 3-foot (0.9 m) length of sound attenuator at the end (Figure 1).

Where runs are required to be installed in unconditioned spaces every attempt should be made to limit the length of the duct run to 12-feet or less using the proper R-factor for the application. However, as an air duct, there is no limit to the length used other than its ability to deliver the air.

Small ducts have a much higher effective efficiency than the R-factor indicates because the R-factor is based on flat wall thickness, which is appropriate for large round ducts. The small ducts were reviewed by the International Code Council Evaluation Services for compliance with LC-1001 (Listing Criteria for SDHV Air Distribution Systems). If the local code requires a minimum R-factor, you can use the evaluation report as justification for installing a small duct system with a slightly lower R-factor. The certification can be found online at (http://www.icc-es-pmg.org/Listing_Directory/pdf/PMG-1002.pdf).

CONFORMS TO UL STD 181
 CERTIFIED TO
 CAN/ULC STD S110-M86



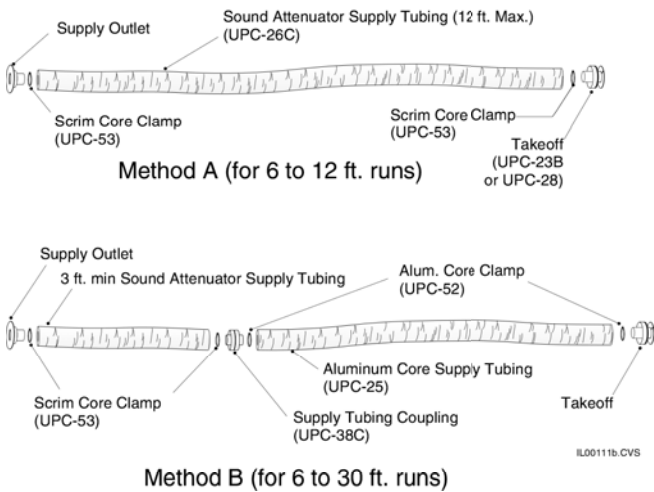

Figure 1: Assembly of Branch Duct Runs

Construction

The aluminum supply tubing is supplied in 25-foot (7.7- m) lengths while the sound attenuator tubing is supplied in 12-foot lengths. Both the aluminum and sound attenuator tubing can be cut as needed. As shown in Figure 2, both the standard and R-4 models have 3 components.

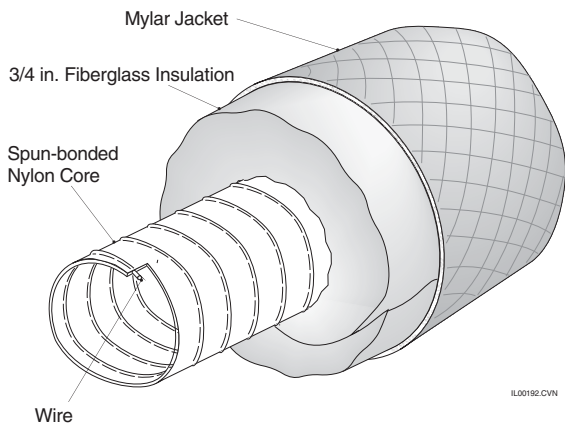

Figure 2. Typical tubing Construction (Standard and R-4)

The inner layer/core is made of two-ply corrugated aluminum for the supply tubing or spun bound nylon for the sound attenuator. The outer jacket for both models are made of two-ply reinforced reflective mylar; providing a vapor seal to prevent leakage and moisture migration, and increases the insulation factor by reducing the radiant heat

transfer. Fiberglass blanket insulation fills the void between the jacket and core of the tube.

The standard and the R-4 duct have one insulation layer and vapor barrier. The R6 and R8 ducts both have two layers of insulation and a double vapor seal for both supply and sound attenuator tubing.

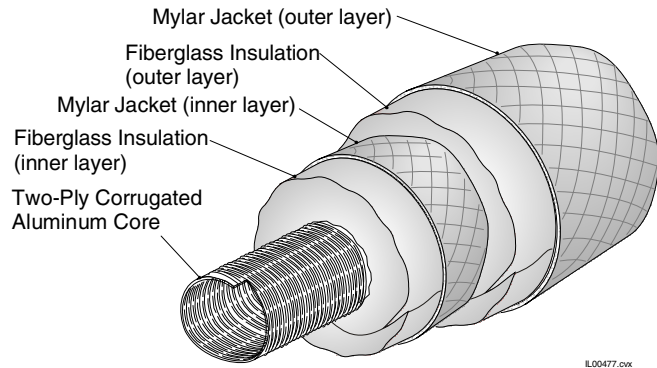

Figure 3. Typical Supply Tubing Construction (R-6 and R-8)

Duct Heat Gain/Loss

Whenever a duct is installed in an unconditioned space, the heat gain and loss calculations must include duct loss. These are based on both thermal losses and losses due to leakage for a typical installation.

The R-factor is calculated per the Air Diffusion Council (ADC) Flexible Duct Standard. This code assumes that the duct wall is flat. This assumption works well for conventional ducts because the duct radius is usually quite large. However, for small ducts, assuming the duct wall is flat overestimates the thermal losses. Therefore, the R-factor specified for a small duct may be less than the value required for a conventional duct. This is described as an equivalent R-factor in Table 1 and is further explained in the International Code Council report (PMG-1002).

Noise Level

Noise level is directly related to the rate at which air is being discharged from each outlet. In general, lower airflow means lower noise levels; therefore additional duct runs will be required. Refer to table 3 as a guide in designing a duct layout that will meet your specific sound level requirements.

Model Specifications

Certifications:

UL Standard 181 *Flexible Air Ducts*

ICC-ES PMG listed (meets the following)

2009 *International Mechanical Code (Duct Systems)*

2009 *International Residential Code (Duct Systems)*

2009 *IAPMO Uniform Mechanical Code (Duct Systems)*

Classification: Air Duct per UL Standard 181

Smoke Developed Rating: less than 50

Flame Spread Index: less than 25

Inside Diameter: Model UPC-25/26: 2.0 inch (50 mm)
Model UPC-225/226: 2.5 inch (63 mm)

Outside Diameter: See table 1 and 2

Duct Material: Two-ply corrugated aluminum
Spun Bound Nylon

Filter Particle Size: 5µ

Insulation: Fiberglass

Vapor Barrier: Reinforced Aluminized Mylar

Min. Pressure: negative 0.5-inch w.c. (125 Pa)

Max. Pressure: 4.0 inches w.c. (1000 Pa)

Max. Velocity: 5000 ft/min (25 m/s)

Min. Length: 3 ft (1 m) *sound attenuator*
None *supply tubing*

Max. Length: None *sound attenuator*
30 ft (9 m) *supply tubing*

Support Distance: every 6-ft (2 m)

Min. Inside Bend Radius: 6 inch (150 mm)

R-Factor: see Table 1

Table 1. Duct R-Factor (English)

Model	Outside Dia, inch	R-factor °F-hr-ft ² /Btu	
		Rated*	Effective**
UPC-26C	3.5	3.3	4.0
UPC-26CR4	4.0	4.2	5.2
UPC-26CR6	5.0	6.0	7.2
UPC-26CR8	6.0	8.0	9.1
UPC-226	4.0	3.3	5.4
UPC-226R4	4.5	4.2	7.0
UPC-226R6	5.5	6.0	10.3
UPC-226R8	6.5	8.0	13.4

* per ADC Flexible Duct Standard, based on flat thickness, k=.24 Btu-in/h•ft²•°F

** per ASHARE 2001 Fundamentals Handbook p. 23.21, based on curved thickness

Note: Data at 15 ft duct length at 120°F

Table 2. Duct R-Factor (Metric)

Model	Outside Dia, mm	R-factor W/(m2-K)	
		Rated*	Effective**
UPC-26C	89	18.7	22.7
UPC-26CR4	102	23.8	29.5
UPC-26CR6	127	34.0	40.9
UPC-26CR8	152	45.4	51.6
UPC-226	102	18.7	30.6
UPC-226R4	114	23.8	39.7
UPC-226R6	140	34.0	58.5
UPC-226R8	165	45.4	76.1

* per ADC Flexible Duct Standard, based on flat thickness, k=.24 Btu-in/h•ft²•°F

** per ASHARE 2001 Fundamentals Handbook p. 23.21, based on curved thickness

Note: Data at 15 ft duct length at 120°F

Table 3. Unico System Sound Level Recommendations

Sound Level	Approx. dB(A)	2-inch Outlet		2 ½ inch Outlet		Recommended Application
		CFM	Outlet/Ton*	CFM	Outlet/Ton*	
Ultra Low	25	14	14	17	12	Multimedia Rooms
Very Low	27	19	11	23	9	Rooms with Hard Surfaces (wood or concrete floors and walls)
Low **	29	30	7	36	6	Rooms with Carpet, Drapes, Furniture
Normal	32	40	5	50	4	Large Rooms or Where Sound is not Critical (min. number of outlets)
Excessive	35	50+	4	60+	3	Industrial Environments

* The number of outlets presume that the total airflow meets the minimum required by the air handler

** Recommended

- Outlets/Ton is based on rated minimum rated airflow of 200 CFM per nominal ton

- dB(A) is A-weighted Sound Pressure level measured 3 ft (1 m) from outlet in a reverberant room 20 x 30 ft.

NOTE: The actual sound levels measured in a room will vary depending on how the duct was installed (bends, wrinkles, outlet design) and the room environment (carpeted, draperies, etc.). Also, the overall sound in the room depends on the number of outlets in that room.

UnicoSystem Measured Sound Pressure Level in Occupied Space

